

CFW900 VARIABLE SPEED DRIVE

Complete solution with
high performance and
safety combined with
maximum flexibility and
connectivity

Industrial Motors

Commercial &
Appliance Motors

Automation

Digital &
Systems

Energy

Transmission &
Distribution

Coatings



Driving efficiency and sustainability



SUMMARY

Introduction	04
WEG exclusive high performance technology	07
Complete solution for permanent magnet motors	07
Intelligent thermal management	08
Human-machine interface	09
WEG solutions	10
Connectivity	13
In line with Industry 4.0	13
Safety	14
Features	15
Applications	16
Coding	17
Specification	18
Accessories	22
Mechanical installation	23
Dimensions and weights	24
Protection rating	24
Standards	25
Technical data	26
Block diagram	28

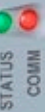
The WEG logo is displayed in a stylized, bold font within a rectangular border.Two indicator lights are shown: a green light labeled 'STATUS' and a red light labeled 'COMM'.

STATUS
COMM

weg

STATUS
COMM

Run ~ R1 1800rpm 02:22
Menu Principal
Status
Diagnósticos
Configurações
Assistentes
Procura NetID

CFW900
SYSTEM DRIVE

Run ~ R1 1800rpm 02:22
Menu Principal
Status
Diagnósticos
Configurações
Assistentes
Procura NetID

CFW900
SYSTEM DRIVE

Complete solution with high performance and safety combined with flexibility and connectivity

The CFW900 is a high-tech VSD for driving and controlling three-phase induction and permanent magnet motors. It offers excellent static and dynamic performance and highly precise torque, speed and position control. It can be used in a wide range of applications due to its high overload capacity.

Thanks to its technology, the CFW900 variable speed drive provides energy savings, safety, increased productivity and quality in the process network in which it is implemented. It allows quick and easy access to the application information and configuration settings.

Using a menu structure, the new interface of the CFW900 line offers an unprecedented user interactive experience, providing settings and configurations with a detailed description of the parameters right on the HMI, in addition to event logs with date and time and a setup wizard.

Power ranges¹⁾

- 1.1 to 2.2 kW – 1.5 to 3.0 cv / 200-240 V_{AC} single-phase or three-phase
- 1.1 to 90 kW – 1.5 to 125 cv / 200-240 V_{AC} three-phase
- 1.1 to 440 kW – 1.5 to 550 cv / 380-480 V_{AC} three-phase
- 1.5 to 37 kW – 2 to 50 cv / 500-600 V_{AC} three-phase

Note: 1) For more power values, contact WEG Automation.

Normal Duty (ND)

- 110% for 60 seconds every 5 minutes
- 150% for 3 seconds every 5 minutes

Heavy Duty (HD)

- 150% for 60 seconds every 5 minutes
- 200% for 3 seconds every 5 minutes

Certifications





Benefits



Easy operation



Efficiency and high performance



Connectivity



Advanced energy saving function



High power density



Reduced size



Functional safety



3C2 class tropicalization and conformal coating in the standard product or optional 3C3 class according to IEC 60721-3-3



Modern graphic HMI



Long cables to the motor, providing greater flexibility



Connection for motor thermistor-PTC



WEG high performance technology

Vectrue technology®

Different types of controls for your application

Induction motor

- Scalar: motor speed control with slip compensation.
- VVW (Voltage Vector WEG) – voltage vector control: motor speed control with automatic adjustment to load and power supply variations.
- Sensorless vector (without encoder) – induction motors: torque and speed vector control with excellent dynamic response, even at low speeds.
- Vector with encoder: the encoder module makes the interface between the CFW900 and the motor, providing a closed-loop speed and position control with excellent precision and dynamic response across the entire speed range (even with the motor stopped).

PM motor

- VVW PM is a method to control permanent magnet motors. It is ideal for medium and high speed applications where the main requirement is energy efficiency, such as: fans, pumps and compressors.

Advanced Energy saving function

The *Energy saving function*¹⁾ is intended to control the motor stator flux so that it operates at the optimum point of efficiency, seeking maximum energy savings. This way, it reduces the motor losses and improves the system performance. This new technology brings advantages for applications with variable and constant torque loads.

Note: 1) The energy saving function is only available for induction machines. For synchronous machines, the MTPA function is used. For further information, refer to the programming manual.

Complete solution for permanent magnet motors

High efficiency and performance solution for your application

The CFW900, together with permanent magnet motors, offers the highest energy efficiency solution on the market. A perfect match for applications that require speed variation, low noise and a small size. In the *Sensorless* mode, the system — composed of a permanent magnet motor and the CFW900 — is capable of performing torque control at zero speed without forced ventilation.

The CFW900 variable speed drive has a special software application for sensorless drive and control of permanent magnet motors with an exclusive control strategy named “Maximum Torque per Ampere”. This control combines the components of alignment torque with reluctance torque, resulting in an excellent high-efficiency drive system. WEG technology provides the industry greater efficiency, quality and savings.



Intelligent thermal management

Due to the constant evolution of industrial processes and machines, efficient and effective solutions are increasingly required. The CFW900 has a unique thermal management function that allows its use in environments with different temperatures. From an integrated system, the VSD can measure the ambient temperature and **configure itself** by varying its switching frequency, thus becoming a **versatile** VSD and enabling its use in different industrial applications.

- Reduces the need to size the CFW900 for applications with possible operation at high temperatures.
- Keeps the VSD and the motor operating in adverse conditions of higher temperature, avoiding fault conditions that cause the system to stop.
- In addition to the optimized performance, the fans can be monitored via parameters, which will indicate the speed and the running time, ensuring better performance and low energy consumption.



MUCH + ADVANTAGES

In addition to its modernity and high performance, the CFW900 offers many other benefits for your application:

- Operation at ambient temperature from -10 °C to 50 °C¹⁾
- Easy fan removal for cleaning or replacement
- Improved control type methodology
- Optimal Braking®
- Higher power density



Menu navigation



Robustness



Easy operation



Simple monitoring

Note: 1) In models with frames A, B, C and D.

Human-machine interface

The CFW900 HMI offers a smart, modern and easy-to-use interface with simple and fast interaction.



High performance graphic HMI

There are three main screens, which can be configured to display up to nine variables each.



Programming

All the HMI operation is based on menus, which contain the reading and writing variables. The menus are divided into levels, containing menus and submenus.



Diagnostics

To simplify the diagnosis of faults and problems in the application or in the motor, the CFW900 can store the statuses at a given time interval — such as: faults, alarms, event history, all of them saved with the RTC date and time in .csv files.



Selectable languages

The user can choose the language of the HMI: Portuguese, English or Spanish.¹⁾

Note: 1) To check the other languages available, consult the programming manual.

WEG solutions

The CFW900 offers a free tool package in its standard version, adding flexibility and versatility to the VSD.

SoftPLC

Available in the standard version, this software function adds to the CFW900 the functionalities of a programmable logic controller (PLC), allowing the creation of your own software applications, ensuring flexibility and lower costs. This functionality streamlines operation and increases performance, in many cases, eliminating the need for an external PLC, optimizing and simplifying the system.



WPS – WEG Programming Suite

The WPS software is a WEG integrated tool that assists in the creation of automation applications, enabling graphic monitoring, parameter setting and programming in Ladder language.



Monitoring

You can view dashboards and graphs of the drive performance.



Parameter list

Allows navigation of numeric parameters, enumerations and bit string with parameter description and text containing detailed help.



Parameter backup

Allows recording backups. The backup, when restored, performs the comparison with the present parameter setting.

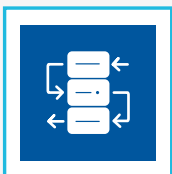

Oriented start-up

Allows performing the parameter setting following an oriented sequence.



Trend

Allows creating graphs containing multiple channels of different scales and units. It has the option to share the screenshot or data through data file in the .csv file.

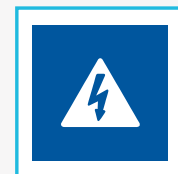

Fault, alarm and event log

Allows consulting the history of the device's faults, alarms and event logs. It has the option to share the logs through data file in the .csv file.

The WPS programming software is available on the website: www.weg.net.

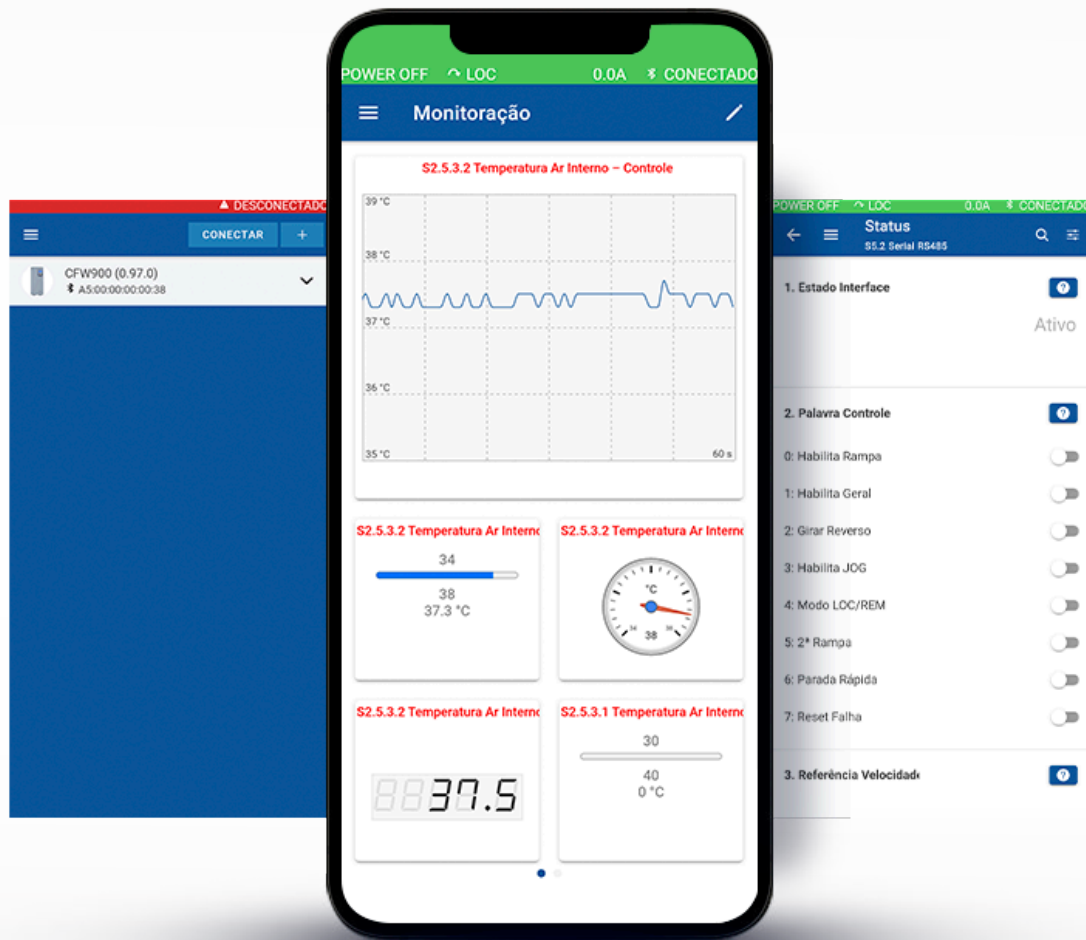

Information at your fingertips

Developed to be the best VSD on the market and bring more convenience and flexibility to the operation, maintenance and management of your drive, the CFW900 has Bluetooth® communication and the free WPS Mobile app. It allows monitoring, naming, tracking in the plant and setting the parameters of your VSD.

The new WPS Mobile app is available for Android and IOS. Download it and learn more about this WEG solution.

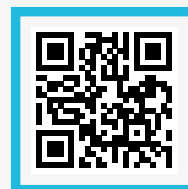



Connectivity

The CFW900 can be connected to the main industrial communication networks without additional modules, as it has two switch Ethernet ports for EtherNet/IP, Modbus-TCP and MQTT communication, and a serial port (RS485) for Modbus-RTU communication. Furthermore, by adding the plug-in module, communication can be expanded to other industrial protocols, such as Profibus-DP, CANopen, DeviceNet and EtherCAT.

The new CFW900 HMI with Bluetooth® connectivity is ideal for panel builders and repair shops and allows programming, monitoring, parameter backup and much more via tablets or smartphones.

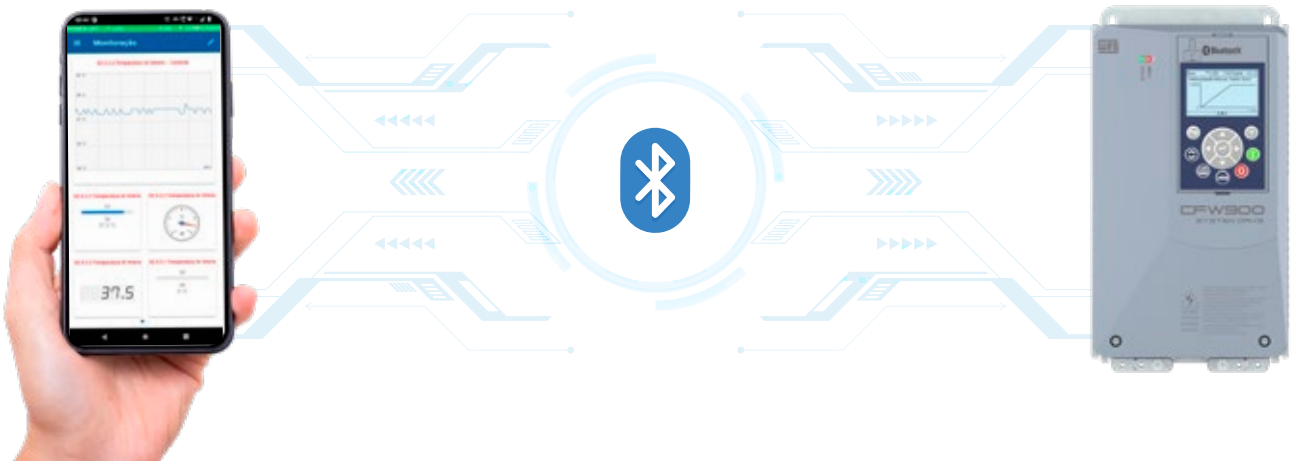

In line with Industry 4.0

With the constant evolution and search for higher productivity, industries are increasingly investing in the automation and digitization of their processes. The CFW900 VSD has native integration and is easy to implement with the **WEG Motion Fleet Management (MFM)** solution, which allows online monitoring and maintenance management of the industrial drive fleet.

Using the Ethernet port available on the standard product, your drive can publish the relevant drive data on the MFM and thus provide a way to optimize the operation and maintenance resources, increasing performance and reducing costs by means of the preventive and predictive maintenance of your application.



Note: 1) For further information about the WEG Motor Fleet Management, see the catalog of the solution.

Safety

Machine reliability has become a major concern, and the CFW900 was therefore developed for applications where safety is essential.

Safety stop function - Safe Torque Off (STO) and SS1

The CFW900 has the STO and SS1 safety functions built-in the standard product, making it easier to meet the safety requirements of the machine and the application.

STO (Safe Torque Off)

Once activated, the STO function immediately switches off the VSD output to the motor, disconnecting the supply of torque generating power.

The STO function is also used for preventing unexpected machine starts or for emergency stops, in compliance with stop category 0 (IEC 60204-1).

This function is applicable where the motor can be stopped soon enough by the load itself or when motor coasting is not safety-relevant. The STO function is widely used in many types of machines: with moving shafts, handling equipment, conveyors, extruders and mixers.

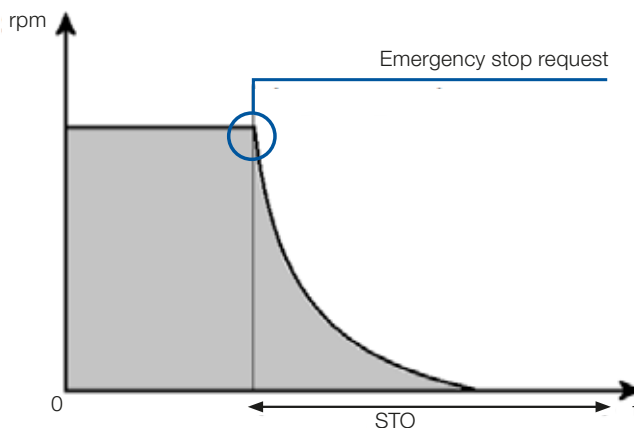

SS1 (Safe Stop)

Once activated, the SS1 function first enables the motor deceleration ramp and, after the programmed time, automatically enables the STO function. The SS1 function can be used to implement a controlled stop with available energy, so that the deceleration is performed first and then the power supply to the motor is disconnected, in compliance with stop category 1 according to IEC 60204-1. This function is used when, in case of a safety-related fault, the drive must first stop the motor and then enter the STO state.

It is typically used to brake motors at high speed as quickly as possible or to stop loads with high inertia where the motion needs to be stopped before transitioning to the no torque state. The most common applications are rolling mills, saws, conveyors, fans, mills, winders, extruders and mixers.

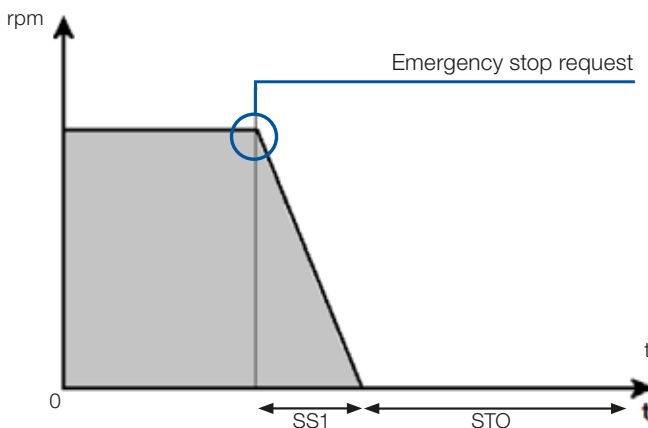

Safety functions built-in the CFW900 VSD, making it easier to meet the safety requirements of the machine and the application.



Fewer components and no additional cabling required, saving space and installation costs.



No electromechanical components, resulting in faster responses and a higher degree of productivity.



Due to the SIL 3/PL e safety level, the CFW900 with safety functions does not require external safety relays for monitoring cables and emergency-stop pushbuttons.

Features

Inductor on DC link reduces harmonic distortion

The CFW900 VSDs are equipped with a DC link inductor for harmonic mitigation, providing compliance with the requirements of IEC 61000 parts 3-2 and 3-12, related to the injection of harmonics into the network. In VSDs with three-phase power supply, we have $THDi \leq 42\%$ for operation with output current between 75 and 100% of the ND (Normal Duty) rated current.

Built-in RFI suppressor filter

The CFW900 VSD standard version has a built-in RFI filter, meeting the requirements of the electromagnetic compatibility directive.

Conformal coating

Application of special varnish on the CFW900 electronic boards to extend the service life, protecting against dust, humidity and corrosive chemical substances.

Class 3C2 protection is standard for the entire CFW900 line, and it complies with IEC 60721-3-3. Also available in the Extra-Coating version, class 3C3, as an optional feature.

Control circuit with independent power supply

24 Vdc power supply to keep the control and communication circuit energized via an external source, without the need for power supply in the power circuit.

Motor temperature monitoring

Monitoring of the motor temperature readings (PTC, Pt-100), providing motor thermal protection.¹⁾

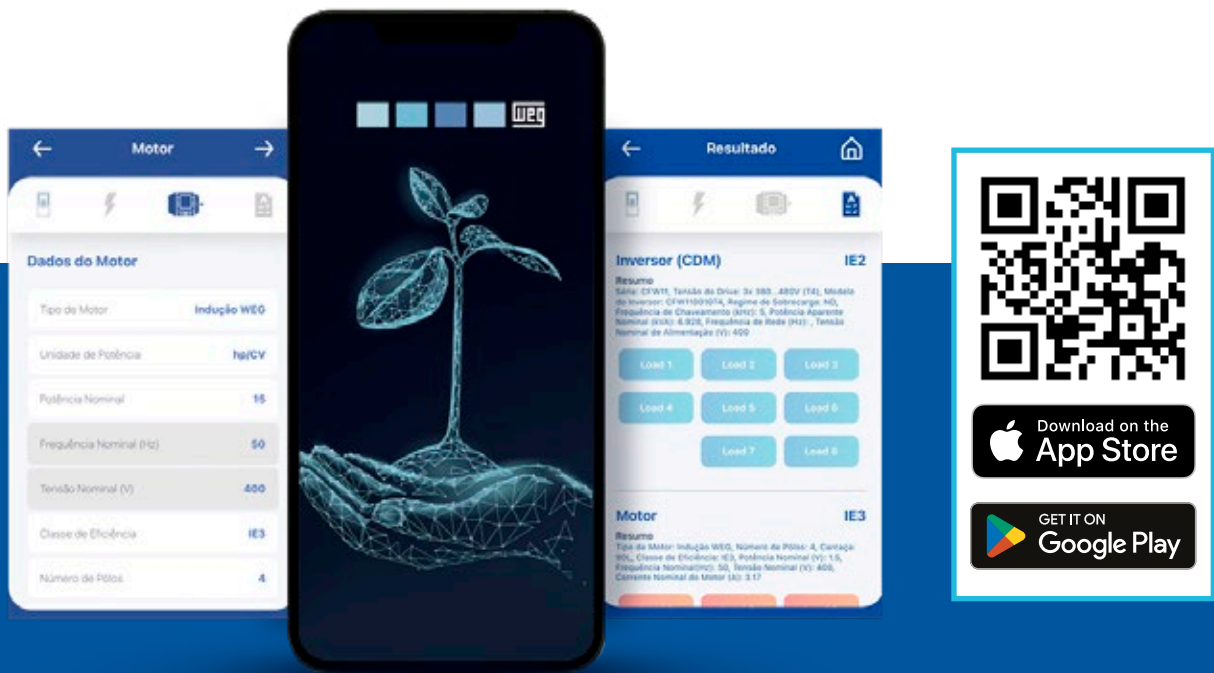

Developed following international standards

WEG, seeking to ensure that its products have an increasingly high energy efficiency level, developed the new CFW900 VSD in line with the new European Ecodesign directive, which establishes mandatory minimum energy performance standards for integrated systems.

To help customers obtain power information based on operating points, WEG developed a calculation app that will classify the VSD efficiency and also the system efficiency for motors used together with the VSDs. It can be obtained for free at the App Store and Google Play.

Note: 1) Temperature Monitoring: through PTC sensors (available by default, using AI and the AO of the IOS Module) or PTC/Pt-100/Pt-1000 (with TEMP-01 accessory module).

Applications



Pumps and fans



Compressors



Load hoisting



Mills and centrifuges

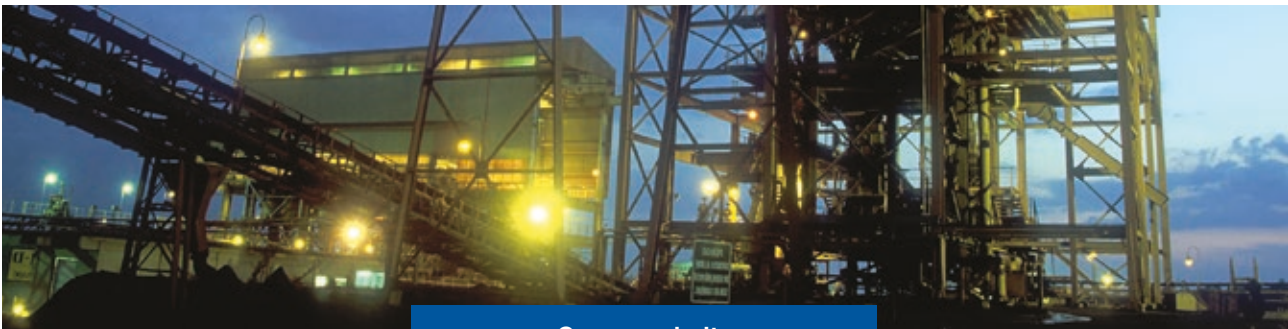

Conveyor belts



Machines and processes in general

Coding¹⁾

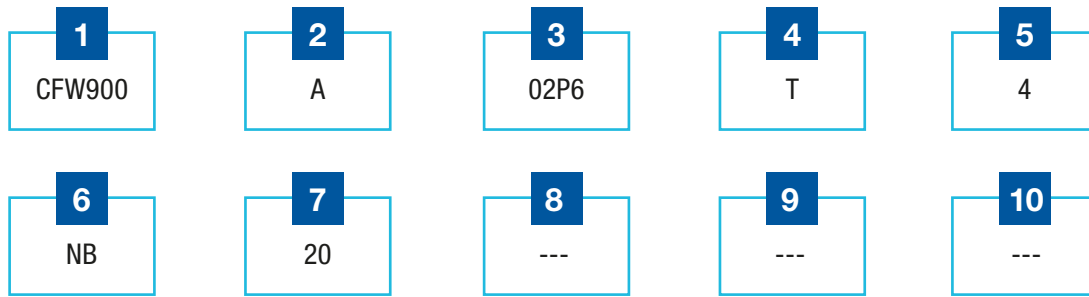

- 1 - CFW900 variable speed drive
- 2 - CFW900 size according to the table below
- 3 - Rated output current according to the table below

Size	Single-phase or three-phase	Three-phase		
	200 - 240 V _{AC}	200 - 240 V _{AC}	208 - 240 V _{AC}	380 - 480 V _{AC}
A	04P6 = 4.6 A 06P0 = 6.0 A 07P5 = 7.5 A 10P0 = 10.0 A	04P6 = 4.6 A 06P0 = 6.0 A 07P5 = 7.5 A 10P6 = 10.6 A 13P0 = 13.0 A 19P0 = 19.0 A		02P8 = 2.8 A 03P6 = 3.6 A 04P8 = 4.8 A 06P5 = 6.5 A 09P6 = 9.6 A 14P0 = 14.0 A 17P0 = 17.0 A
B		26P0 = 26.0 A 34P0 = 34.0 A 45P0 = 45.0 A		26P0 = 26.0 A 33P0 = 33.0 A 39P0 = 39.0 A
C		56P0 = 56.0 A 70P0 = 70.0 A 80P0 = 80.0 A		50P0 = 50.0 A 62P0 = 62.0 A 74P0 = 74.0 A
D				96P0 = 96.0 A 0124 = 124 A 0146 = 146 A
E			0110 = 110 A 0135 = 135 A 0150 = 150 A	0172 = 172 A 0195 = 195 A 0250 = 250 A
F			0315 = 315 A 0370 = 370 A	0315 = 315 A 0370 = 370 A
G				0430 = 430 A 0480 = 480 A 0540 = 540 A 0601 = 601 A
H				0760 = 760 A

Note: 1) ND rated currents.

4 - Number of phases

B	Single-phase or three-phase power supply
T	Three-phase power supply

5 - Rated voltage

2	200-240 V
4	380-480 V
5	500-600 V

6 - Internal dynamic braking

NB	Without internal dynamic braking IGBT
DB	With internal dynamic braking IGBT

7 - Protection rating

20	IP20 protection rating
21	IP21 protection rating
N1	NEMA UL Type 1 protection rating

8 - Safety functions

Y2	With safety functions (STO AND SS1) in accordance with EN 61800-5-2
----	---

9 - HMI version

Blank	HMI without Bluetooth®
B	HMI with Bluetooth®

10 - Special hardware versions

Blank	Standard hardware
HEC	Products with extra-coating boards
Hxx	Special hardware

11 - Special software version

Blank	Standard software
Sxx	Special software

Specification

CFW900 IP20 or NEMA1 200 - 240 V version

CFW900 variable speed drive						Maximum applicable motor ¹⁾									
Code	Power supply (V)	Frame	Braking IGBT	Rated output current (A)		Normal duty (ND)			Heavy duty (HD)						
						IEC		UL	IEC		UL				
						60 Hz	50 Hz	60 Hz	60 Hz	50 Hz	60 Hz				
				220 V _{AC}	230 V _{AC}	230 V _{AC}	220 V _{AC}	230 V _{AC}	230 V _{AC}						
ND	HD	cv	kW	HP	cv	kW	HP								
CFW900A04P6B2	Single-phase or three-phase	A	DB	4.6	4.6	1.5	1.1	1.5	1.5	1.1	1.5				
CFW900A06P0B2				6	6	2	1.5	2	2	1.5	2				
CFW900A07P5B2				7.5	7.5	2	1.5	3	2	1.5	2				
CFW900A10P0B2				10	10	3	2.2	3	3	2.2	3				
CFW900A04P6T2	200-240			A	DB	4.6	4.6	1.5	1.1	1.5	1.5	1.1	1.5		
CFW900A06P0T2						6	5	2	1.5	2	1.5	1.5	2		
CFW900A07P5T2						7.5	6.8	2	1.5	3	2	1.5	2		
CFW900A10P6T2						10.6	9.6	3	3	3	3	2.2	3		
CFW900A13P0T2						13	11	4	3	5	3	3	3		
CFW900A19P0T2						19	16	6	5.5	7.5	5	4	5		
CFW900B26P0T2						26	22	10	7.5	10	7.5	5.5	7.5		
CFW900B34P0T2						34	28	12.5	9.2	10	10	7.5	10		
CFW900B45P0T2		45	35			15	11	15	12.5	9.2	10				
CFW900C56P0T2		Three-phase	C			DB	56	47	20	15	20	15	11	15	
CFW900C70P0T2							70	59	25	18.5	25	20	15	25	
CFW900C80P0T2							80	70	30	22	30	25	19	30	
CFW900D0110T2	208-240			D	NB or DB		110	92	40	30	40	30	22	30	
CFW900D0135T2							135	110	50	37	50	40	30	40	
CFW900D0150T2							150	124	60	45	60	50	37	50	
CFW900E0172T2							172	150	60	55	75	60	45	60	
CFW900E0195T2							195	160	75	55	75	60	45	60	
CFW900E0250T2							250	211	100	75	100	75	55	75	
CFW900F0315T2				F	NB		NB	315	263	125	90	125	100	90	100
CFW900F0370T2								370	315	150	110	150	125	90	125

Note: 1) The motor powers are based on WEG 3-phase, 4-pole 220 V or 230 V W22 IR3 Premium motors. The motor currents may vary according to the speed and manufacturer; therefore, use the values above for guidance only. The CFW900 must be properly sized according to the rated current of the motor used.



Specification

CFW900 IP20 or NEMA1 380 - 480 V version

CFW900 variable speed drive					Maximum applicable motor ¹⁾									
Code	Power supply (V)	Frame	Braking IGBT	Rated output current		Normal duty (ND)				Heavy duty (HD)				
						IEC			UL	IEC			UL	
				60 Hz	50 Hz	60 Hz	60 Hz	60 Hz	50 Hz	60 Hz	60 Hz			
				380 V _{AC}	400 V _{AC}	440 V _{AC}	460 V _{AC}	380 V _{AC}	400 V _{AC}	440 V _{AC}	460 V _{AC}			
ND	HD	cv	kW	cv	HP	cv	kW	cv	HP					
CFW900A02P8T4	Three-phase	380-480	A	DB	2.8	2.4	1.5	1.1	1.5	2	1	1.1	1.5	1.5
CFW900A03P6T4					3.6	2.8	2	1.5	2	1.5	1.1	1.5	2	
CFW900A04P8T4					4.8	3.9	3	2.2	3	2	1.5	2	3	
CFW900A06P5T4					6.5	5.3	3	3	4	5	3	2.2	3	3
CFW900A09P6T4					9.6	8	6	4	6	7.5	4	3	5	5
CFW900A14P0T4					14	12	7.5	7.5	10	10	6	5.5	7.5	7.5
CFW900A17P0T4					17	17	10	7.5	12.5	10	8	7.5	12.5	10
CFW900B26P0T4					26	21	15	11	20	20	13	11	12.5	15
CFW900B33P0T4					33	28	20	15	25	25	13	11	20	20
CFW900B39P0T4					39	33	25	18.5	30	30	20	15	20	25
CFW900C50P0T4			50	40	30	22	40	40	20	18.5	20	30		
CFW900C62P0T4			62	50	40	30	50	50	20	22	20	40		
CFW900C74P0T4			74	62	50	37	60	60	40	30	40	50		
CFW900D96P0T4			96	75	60	45	75	75	50	37	60	60		
CFW900D124T4			124	103	75	55	100	100	60	55	75	75		
CFW900D146T4			146	124	100	75	125	125	75	55	75	100		
CFW900E0172T4			172	146	125	90	125	150	100	75	125	125		
CFW900E0203T4			203	161	150	110	150	175	100	90	125	125		
CFW900E0242T4			242	190	175	132	200	200	125	90	150	150		
CFW900F0315T4			315	263	200	185	250	250	200	150	200	200		
CFW900F0370T4	370	315	250	185	300	300	200	185	250	250				
CFW900G0430T4	430	370	300	220	350	350	250	220	300	300				
CFW900G0480T4	480	430	350	260	400	450	300	220	350	350				
CFW900G0540T4	540	480	400	300	475	500	350	260	400	450				
CFW900G0601T4	601	515	450	355	500	550	350	300	450	475				
CFW900H0760T4	760	601	550	440	650	700	450	355	500	550				

Note: 1) The motor powers are based on WEG 3-phase, 4-pole 380 V or 440 V W22 IR3 Premium motors. The motor currents may vary according to the speed and manufacturer; therefore, use the values above for guidance only. The CFW900 must be properly sized according to the rated current of the motor used.



Specification

CFW900 IP20 or NEMA1 500-600 V version

CFW900 variable speed drive				Maximum applicable motor ¹⁾										
Code	Power supply (V)		Frame	Braking IGBT	Rated output current (A)		Normal duty (ND)				Heavy duty (HD)			
							50 - 60 Hz			NEC	50 - 60 Hz			NEC
							525 V _{AC}	575 V _{AC}	600 V _{AC}	575 V _{AC}	525 V _{AC}	575 V _{AC}	600 V _{AC}	575 V _{AC}
ND	HD	HP/kW	HP/kW	HP/kW	HP	HP/kW	HP/kW	HP/kW	HP					
CFW900B02P9T5	Three-phase	500-600	B	DB	2.9	2.7	2/1.5	2/1.5	2/1.5	2	2/1.5	2/1.5	2/1.5	2.0
CFW900B04P2T5					4.2	2.9	3/2.2	3/2.2	45/20	3	2/1.5	2/1.5	2/1.5	2
CFW900B07P0T5					7	4.2	5.5/4	5/3.7	6/4.5	5	3.2/2	3/2.2	45/20.0	3
CFW900B10P0T5					10	7	7.5/5.5	10/7.5	10/7.5	8	5.5/4	5/3.7	6/4.5	5
CFW900B12P0T5					12	10	10/7.5	10/7.5	12.5/9.2	10.0	7.5/5.5	10/7.5	10/7.5	8
CFW900B17P0T5					17	12	15/11	15/11	15/11	15	10/7.5	10/7.5	12.5/9.2	10.0
CFW900B22P0T5					22	17	20/15	20/15	20/15	20	15/11	15/11	15/11	15
CFW900B27P0T5					27	22	25/18.5	25/18.5	25/18.5	25	20/15	20/15	20/15	20
CFW900C32P0T5					32	27	30/22	30/22	30/22	30	25/18.5	25/18.5	25/18.5	25
CFW900C44P0T5					44	32	40/30	40/30	40/30	40	30/22	30/22	30/22	30
CFW900C54P0T5					54	44	50/37	50/37	50/37	50	40/30	40/30	40/30	40

Note: 1) Rated power values defined based on the rated current of WEG motors at the indicated voltages.



Accessories

By default, the CFW900 comes with: CFW900-IOS, which contains digital and analog inputs and outputs, input for external power supply and RS485 communication; CFW900-4SLOTS, backplane, which allows the installation of up to four accessories (slots A to D); CFW900-REL-01, which provides relay outputs.

The VSDs of the CFW900 line can be equipped with accessories to expand their application possibilities; the accessories are interchangeable between all frames.

Accessory installation

Control accessories expand the drive communication and input/output functions and are mounted in the backplane slots. The slots are interchangeable, and any accessory can be mounted in any slot in any quantity (except for communication network accessories, which are limited to one per VSD).

Name	Description
Communication accessories and functionality expansion	
CFW900-CCAN-W ¹⁾	CAN interface module (CANopen/DeviceNet)
CFW900-ENC-01	Module for connecting an incremental encoder with a signal of up to 310 kHz
CFW900-IOAI-01	Module with 3 analog inputs and 2 isolated analog outputs
CFW900-IOD-01	Module with 8 isolated digital inputs and 8 isolated digital outputs
CFW900-REL-01	Module with 3 digital relay outputs (1 unit supplied as standard)
CFW900-TEMP-01	Module with 6 isolated inputs for PTC/Pt-100/Pt-1000 sensors
CFW900-CPDP-N	Anybus Profibus-DP interface module
CFW900-CPN-IRT-N	Anybus PROFINET IRT interface module
CFW900-CECAT-N	Anybus EtherCAT interface module
Individual HMI, frame and cables for external HMI	
CFW900-IHM-BLT H	HMI with Bluetooth® interface (individual item) (standard for option B) ²⁾
CFW900-HMI	HMI (individual) ²⁾
CFW900-RHMIF	Frame kit for HMI (IP66 protection rating)
CFW900-CCHMIR01M	1 m serial cable for remote HMI
CFW900-CCHMIR02M	2 m serial cable for remote HMI
CFW900-CCHMIR03M	3 m serial cable for remote HMI
CFW900-CCHMIR05M	5 m serial cable for remote HMI
CFW900-CCHMIR07M	7.5 m serial cable for remote HMI
CFW900-CCHMIR10M	10 m serial cable for remote HMI

Notes: 1) It is only possible to use one CFW900-CCAN-W communication module per inverter.
 2) For remote HMI connection, use a D-Sub9 (DB-9) male and female cable with pin-to-pin connections.



Accessories

Name	Description
Others	
CFW900-4SLOTS	Backplane with 4 slots (A through D) to connect accessories (supplied as standard)
CFW900-7SLOTS	Backplane with 7 slots (A through G) to connect accessories
CFW900-KN1A	NEMA1 kit for frame A (standard for option N1)
CFW900-KN1B	NEMA1 kit for frame B (standard for option N1)
CFW900-KN1C	NEMA1 kit for frame C (standard for option N1)
CFW900-KN1D	NEMA1 kit for frame D (standard for option N1)
CFW900-KN1E	NEMA1 kit for frame E (standard for option N1)
CFW900-IP21A	IP21 kit for frame A
CFW900-IP21B	IP21 kit for frame B
CFW900-IP21C	IP21 kit for frame C
CFW900-IP21D	IP21 kit for frame E
CFW900-IP21E	IP21 kit for frame D
CFW900-IP21F	IP21 kit for frame F
CFW900-IP21G	IP21 kit for frame G
CFW900-IP21H	IP21 kit for frame H
CFW900-KMFA	Flange mounting kit Frame A
CFW900-KMFB	Flange mounting kit Frame B
CFW900-KMFC	Flange mounting kit Frame C
CFW900-KMFD	Flange mounting kit Frame D
CFW900-KMFE	Flange mounting kit Frame E
CFW900-KMFF	Flange mounting kit Frame F
CFW900-KMFG	Flange mounting kit Frame G
CFW900-KMFH	Flange mounting kit Frame H
CFW900-KDF-01	Flexible duct kit (intake kit) for frames E, F, G e H
CFW900-KDF-02	Flexible duct kit (exhaust kit) for frames E, F, G e H
CFW900-KMH-01	Removable mounting kit ¹⁾
SDC-8GB	SDC-8GB - 8GB industrial temperature microSD card

Note: 1) Kit applicable to F, G and H frames.

Mechanical installation

Standard installation



Side by side installation¹⁾



Frame	Protection rating	A mm	B mm	C mm	D mm
A	IP20	25	25	10	0
	IP21 / UL Type 1	25	25	10	30
B	IP20	40	45	10	0
	IP21 / UL Type 1	40	45	10	30
C	IP20	110	130	10	0
	IP21 / UL Type 1	110	130	10	30
D	IP20	110	130	10	0
	IP21 / UL Type 1	110	130	10	30
E	IP20	150	250	20	0
	IP21 / UL Type 1	150	250	20	30
F	IP20	150	250	20	0
	IP21	150	250	20	30
G	IP20	150	250	20	0
	IP21	150	250	20	30
H	IP20	150	250	20	0
	IP21	150	250	20	30

Note: 1) Only for frames A, B, C and D: side by side mounting without side clearance with removal of the top sticker.

Surface installation

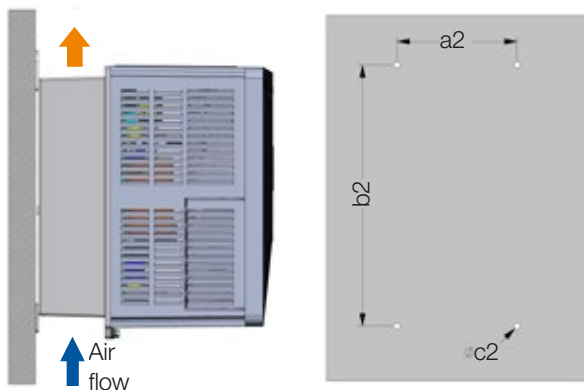

Flange installation

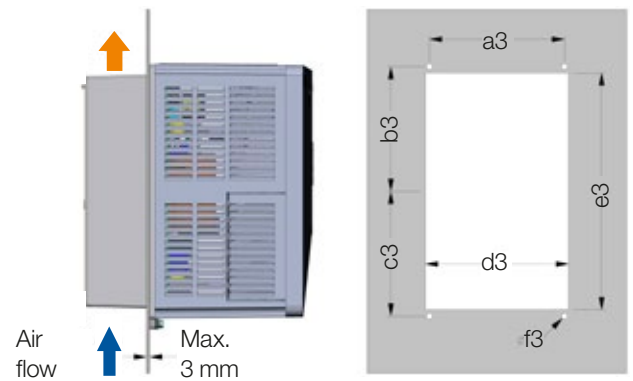

Model	a2 (mm)	b2 (mm)	c2 (M)	a3 (mm)	b3 (mm)	c3 (mm)	d3 (mm)	e3 (mm)	f3 (M)
Frame A	115	250	M5	130	120	120	136	226	M5
Frame B	125	370	M5	150	177,1	177,1	158	342	M5
Frame C	150	425	M6	175	210	210	188	405	M6
Frame D	200	600	M8	220	290	298	238	565	M8
Frame E	200	650	M8	275	320	320	316	620	M8
Frame F	125 ¹⁾	1000	M10	270	497	497	331	957	M10
Frame G	150 ²⁾	12000	M10	350	591,8	591,8	392	1147,6	M10
Frame H	150 ³⁾	1224	M10	425	609,6	609,6	507,5	1183,2	M10

Notes: 1) In frame F there are 3 holes, so the total width between the holes is 250 mm [9.84 in].
 2) In frame G there are 3 holes, so the total width between the holes is 300 mm [11.81 in].
 3) In frame H there are 4 holes, so the total width between the holes is 450 mm [17.71 in].

Dimensions and weights



Size	Dimension (mm) [in]			Weight (Kg) (lb)
	Heigh (A)	Width (L)	Length (P)	
A	269 [10.59]	145.0 [5.71]	222 [8.73]	4.5 9.92
B	385.0 [15.16]	165.2 [6.51]	228 [8.98]	10.0 22.04
C	460.0 [18.11]	200.0 [7.87]	294 [11.57]	20.5 45.2
D	625.0 [24.60]	250.0 [9.84]	294 [11.57]	33.5 73.8
E	675 [26.57]	335.0 [13.19]	358 [14.09]	63.5 140.0
F	1,074.3 [42.30]	370.0 [14.57]	360.1 [14.18]	101 222.6
G	1,267.8 [49.91]	430.0 [16.93]	358.7 [14.12]	185 407.8
H	1,303.4 [51.31]	535.0 [21.6]	425.9 [16.77]	242 533.5

Protection rating

The standard protection rating of the CFW900 is IP20, but it is possible to increase its protection rating to IP21 or UL Type 1 by installing specific kits¹⁾.



Frame A with UL Type 1 kit - "CFW900-KN1A" accessory.

Frame A with IP21 kit - "CFW900-IP21A" accessory.

Note: 1) The kit must be selected according to the size of the VSD.

Standards

Compliance with the standards	
Safety standards	UL 61800-5-1 - Adjustable Speed Electric Power Drive Systems - Part 5-1: Safety Requirements - Electrical, Thermal and Energy. Note: Suitable for Installation in a compartment handling conditioned air
	EN 61800-5-1 - Safety requirements electrical, thermal and energy
	EN 50178 - Electronic equipment for use in power installations
Specification standards	EN 60146 (IEC 146) - Semiconductor converters
	EN 61800-2 - Adjustable speed electrical power drive systems - Part 2: general requirements - Rating specifications for low voltage adjustable frequency AC power drive systems
Electromagnetic compatibility standards (EMC)	EN 61800-3 - Adjustable speed electrical power drive systems - Part 3: EMC product standard including specific test methods
	EN 55011 - Limits and methods of measurement of radio disturbance characteristics of industrial, scientific and medical (ISM) radio-frequency equipment
	CISPR 11 - Industrial, scientific and medical (ISM) radio-frequency equipment
	EN 61000-4-2 - Electromagnetic compatibility (EMC) - Part 4: testing and measurement techniques - Sec. 2: electrostatic discharge immunity test
	EN 61000-4-3 - Electromagnetic compatibility (EMC) - Part 4: testing and measurement techniques - Sec. 3: radiated, radio-frequency, electromagnetic field immunity test
	EN 61000-4-4 - Electromagnetic compatibility (EMC) - Part 4: testing and measurement techniques - Sec. 4: electrical fast transient/burst immunity test
	EN 61000-4-5 - Electromagnetic compatibility (EMC) - Part 4: testing and measurement techniques - Sec. 5: surge immunity test
	EN 61000-4-6 - Electromagnetic compatibility (EMC) - Part 4: testing and measurement techniques - Sec. 6: immunity to conducted disturbances, induced by radio-frequency fields
	EN 61000-4-11 - Testing and measurement techniques - Voltage dips, short interruptions and voltage variations immunity tests
Frame standards	EN 60529 - Degrees of protection provided by enclosures (IP code)
	U _L 50 - Enclosures for electrical equipment
Ecodesign standards	IEC 61800-9-2 Parts 1 & 2 - Adjustable speed electrical power drive systems - Ecodesign for power drive systems, motor starters, power electronics and their driven applications
Functional safety standards	EN 61800-5-2 - Adjustable speed electrical power drive systems - Part 5-2: Safety requirements - Functional
	EN ISO 13849-1 - Safety of machinery - Safety-related parts of control systems - Part 1: General principles for design
	EN 62061 - Safety of machinery - Functional safety of safety-related control systems
	IEC 61508 Parts 1-7 - Functional safety of electrical/electronic/programmable electronic safety-related systems
	EN 60204-1 - Safety of machinery - Electrical equipment of machines - Part 1: General requirements
Directives	
Low-voltage	2014/35/EU
EMC	2014/30/EU
RoHS	2011/65/EU 2015/863/EU
Ecodesign	2009/125/EC
Certificaciones	
U _L and c _{UL}	E184430
CE	
Functional safety	TÜV Rheinland Certificate

Technical data

		B2	T2	T4	T5
Power supply	Input	AC power supply			
		200...240 V rms	Frames A, B and C: 200...240 V Frames D, E and F: 208...240 V	380 to 480 V	500 to 600 V
		Tolerance			
	-15% +10%	Frames A, B and C: -15%+10% Frames D, E and F: -10% +10%	-15% +10%	-15% +10%	
	DC power supply				
	229...400 V _{dc}	Frames A, B and C: 229...400 V _{dc} Frames D, E and F: 252...400 V _{dc}	436...800 V _{dc}	573 ... 1,000 V _{dc}	
	Frequency 50/60 Hz (range: 48...63 Hz)				
	Output	Output frequency: Frames A...D: 0 to 500 Hz Frame E: 0 to 250 Hz			
	Typical power factor	0.93 three-phase input 0.70 single-phase input			
	Overvoltages	Category III (EN 61010 / IEC 61800-5-1 / U L61800-5-1)			
Control	Control types	Scalar - V/f VW: voltage vector control Vector control with encoder Sensorless vector control (without encoder)			
	Supported motors	Induction motor Permanent magnet motor			
	Modulation	PWM SVM PWM for long output cables			
	Measurements and indications	Current measurement accuracy: 5% of the rated current Speed resolution: 1 rpm Built-in real-time clock			
	Switching frequency	Frames A...D: 4 kHz rated - 1...16 kHz adjustable Frame E: 2 kHz rated - 1...8 kHz adjustable Frame F: 2 kHz rated - 1...6 kHz adjustable Frame G and H: 2 kHz rated - 1...7 kHz adjustable			
Environmental conditions	Temperature	The maximum ambient temperature around the heatsink without output current derating: -10 °C to 45 °C (14 °F to 113 °F) for frames E, F, G and H models. -10 °C to 50 °C (14 °F to 122 °F) for other frames.			
	Aggressive environments	Conformal coating 3C2 (standard), 3C3 (optional)			
	Air relative humidity	5% to 95% non-condensing			
	Altitude	Rated up to 1,000 m Maximum 4,000 m with rated output current derating			
	Pollution degree	Degree 2 (according to EN 50178 and UL 508C), with non-conductive pollution. Condensation must not cause conduction through the accumulated residues.			
Protection rating	IP20	Standard protection rate			
	IP21	Using an IP21 kit			
	UL Type 1	With label on top and with conduit kit			
Safety	VSD protection	Overcurrent/short circuit at the output Under/overvoltage at the power Phase loss Overtemperature Overload on the motor, on the braking resistor and on the IGBTs External fault/alarm Phase-ground short circuit at the output			
	Functional safety	Built-in STO (Safe Torque Off) and SS1-t (Safe Stop 1 time controlled) functions Terminals suitable for dry contact or OSSD signals.			
RFI Filter		Built-in the CFW900 Reduced emission category C3 with 200 m shielded cable for motor connection			
Maximum cable length	No output reactance required	200 m (above 100 m it is recommended to use PWM modulation for long cables)			
	With output reactance	200...500 m			
	With sinusoidal filter on the VSD output	500...5,000 m			

Technical data

Inputs	Analog (standard interface)	2 differential analog inputs		
		Isolated from the power circuits		
		Levels: -10/0 to 10 V (11 bits + signal), 0/4 to 20 mA (10 bits)		
		Maximum voltage: 30 V		
		Maximum current: 25 mA		
		Impedance: 400 k Ω (voltage mode), 250 Ω (current mode)		
	Digital (standard interface)	DI1 to DI4: 4 isolated digital inputs		
		Low level: V_{dc} -3 V to 5 V, $I < 1.5$ mA		
		High level: $V_{dc} > 11$ V, $I > 2$ mA		
		Current: 8 mA @ 24 V (Typical)		
		Maximum voltage: 30 V_{dc}		
		Maximum current: 11 mA @ 30 V_{dc}		
		DI5 and DI6		
		2 isolated digital inputs		
Outputs	Analog (standard interface)	2 analog outputs		
		Isolated from the power circuits		
		Levels: 0 to 10 V (12 bits), 0/4 to 20 mA (12 bits)		
		Load: RL 1 k Ω (voltage mode), RL 600 Ω (current mode)		
	Digital (standard interface)	2 digital transistor outputs (NPN)		
		Isolated from the power circuits		
		Maximum current: 40 mA		
		Protected against short circuit to the GND		
Input for microSD ¹⁾ card		Card requirements: Max size 32 GB Industrial temperature (-40 °C to 85 °C) FAT32 file system		
		Communication	RS485	Isolated RS485 interface Modbus-RTU protocol
			Dual port Ethernet network (RJ45)	Two RJ45 Ethernet connectors 10/100 Mbps data rate with built-in switch dual port Protocol Modbus-TCP
			USB	Built-in the CFW900 HMI, mini type B
Bluetooth®	Built-in the CFW900 HMI			
Efficiency rating		Fieldbus	CANopen; DeviceNet; EtherCAT; Ethernet/IP	
		IE2 efficiency (IEC 61800-9-2 / EN 50598-2)		

Notes: 1) MicroSD card not included.

2) Features of CFW900-REL-01, standard on the product.

Block diagram

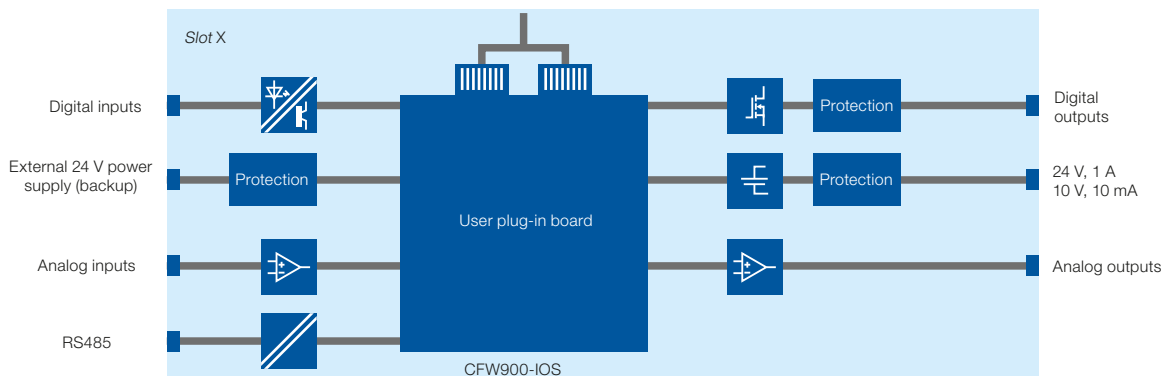
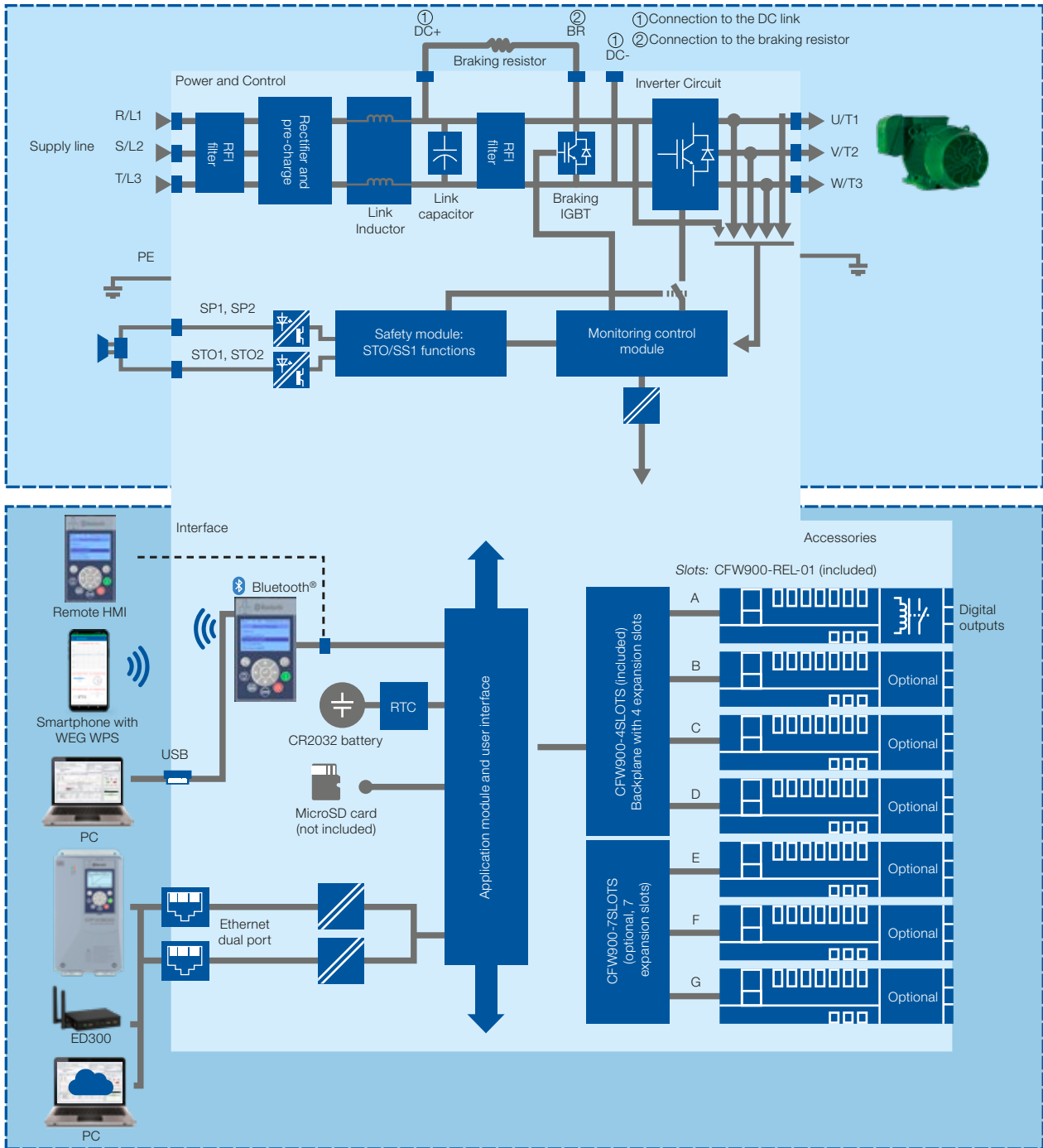

Global presence

is essential, as much as understanding your needs.



Global Presence

With more than 45,000 employees worldwide, WEG is one of the largest electric motors, electronic equipments and systems manufacturers. We are constantly expanding our portfolio of products and services with expertise and market knowledge. We create integrated and customized solutions ranging from innovative products to complete after-sales service.

WEG's know-how guarantees our **CFW900 Variable Speed Drives** are the right choice for your application and business, assuring safety, efficiency and reliability.



Availability is to have a global support network



Partnership is to create solutions that suits your needs



Competitive edge is to unite technology and innovation



Learn More

High performance and reliable products to improve your production process.



Excellence is to provide a whole solution in industrial automation that improves our customers productivity.

Visit: www.weg.net

 youtube.com/wegvideos

The scope of WEG Group solutions is not limited to products and solutions presented in this catalogue.

To see our portfolio, contact us.

For WEG's worldwide operations visit our website



www.weg.net



 +55 47 3276.4000

 automacao@weg.net

 Jaraguá do Sul - SC - Brazil

Cod: 50117020 | Rev: 03 | Date (m/y): 03/2025.

The values shown are subject to change without prior notice.
The information contained is reference values.