

SSW7000

Medium Voltage Soft-Starter

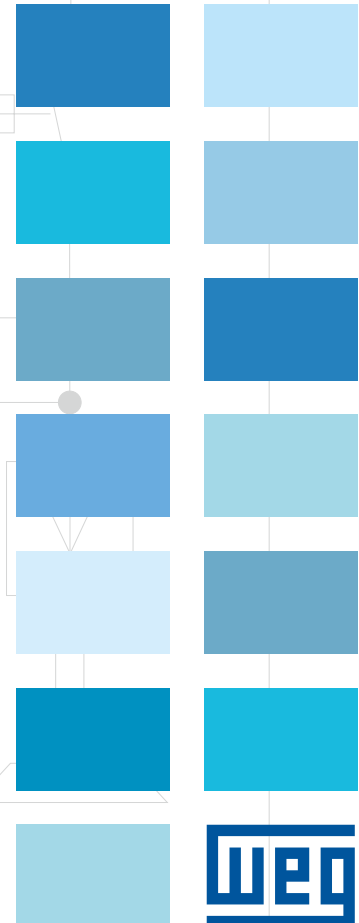
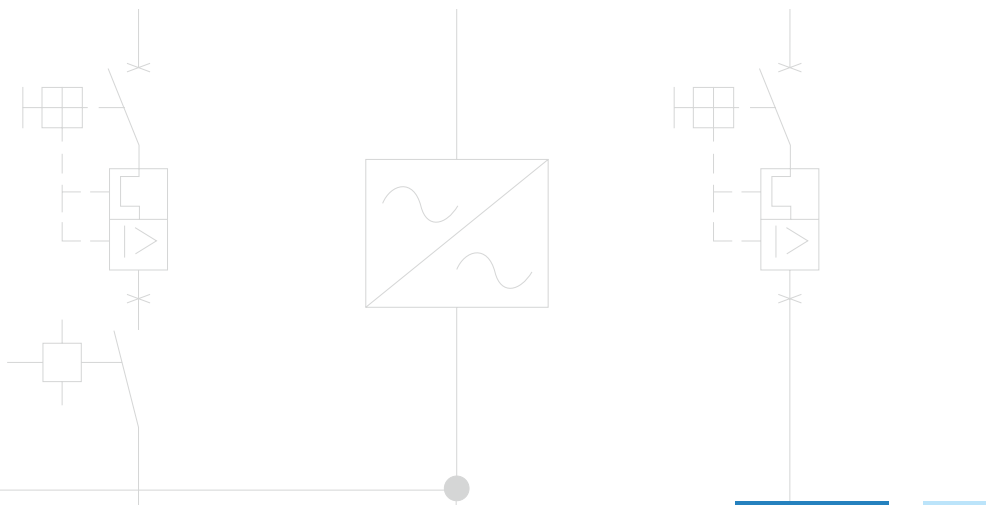

Medium Voltage Soft-Starter

The SSW7000 uses state-of-the-art technology to provide start / stop control and protection for three-phase medium voltage induction motors. Developed to ensure excellent performance, it prevents mechanical shocks from the load, protects the motor against related burnouts or current surges in the power supply and thus, offers a complete solution for various applications.



Size A



Size N

pictures for illustrative purposes only

Certifications

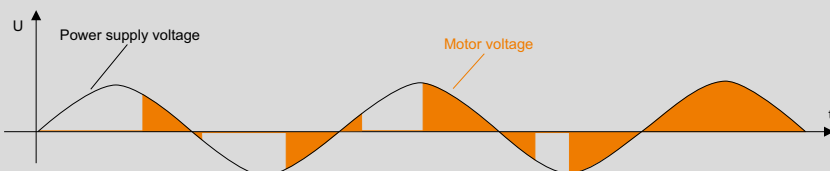

The SSW7000 reduces the voltage applied to the motor at start. As a consequence, motor current and torque is reduced for a smooth start. The motor voltage control is performed with the firing angle control of the thyristors in antiparallel connection.

Features

- Torque control
The SSW7000 features FTC - Flexible Torque Control, technology developed by WEG which uses the vector control and control of direct torque concepts, based on technologies developed for the vector frequency inverters CFW. The FTC is flexible to select the desired torque control according to the type of load applied to the motor (constant loads, quadratic loads, or loads with lower or higher starting torque), providing a smooth start with a linear speed ramp along the entire starting process.
- Accessories can be easily and quickly installed by using the Plug and Play' concept
- Motor voltage: 2.3kV, 4.16kV or 6.9kV
- Power: 750 hp to 4500 hp
- Output current: 180A, 300A and 360A
- Protection Degree: IP41 or Nema 12
- Operating interface (HMI) with graphic LCD
- Real time clock
- Main and bypass vacuum contactors
- Medium voltage fuses
- Power and control insulated by fiber optics
- Flash memory module (accessory)
- SoftPLC Function
- Licence-free software SuperDrive and WLP
- USB connection to PC
- Motor thermal protection - PT100 - 8 channels (optional accessory)
- 5 start modes
- Network communication boards (accessories):
Devicenet, Profibus-DP, Ethernet and Modbus, RS-232 or RS-485



Size A



Size N



- The heatsinks are dimensioned for the heavy duty overload cycle.
- The power stacks are developed in independent modules with wheels, making installation and maintenance easy.

pictures for illustrative purposes only

Enables smooth starting of motors up to rated speed, by eliminating impacts of inrush current on the power supply and by eliminating impacts of mechanical shocks on the load and the coupling. This helps in reducing maintenance of bearings, couplings, gear boxes, pulleys, belts and chains, in addition to protecting the motor.

Characteristics

Plug and play philosophy

The installation of the accessories is based on the plug-and-play philosophy, that is, they are automatically configured when connected to the SSW7000, ensuring a faster and easier process.

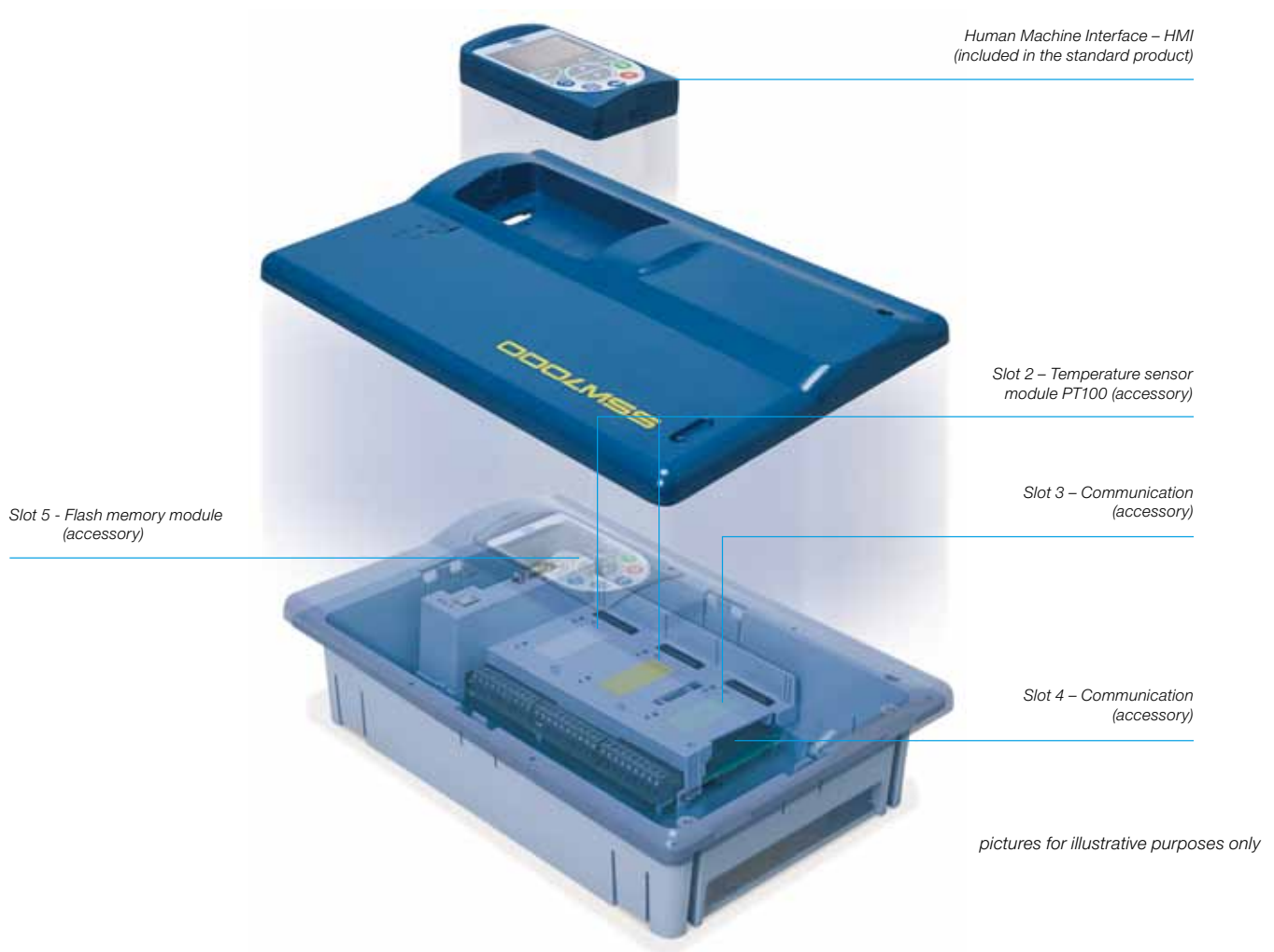

Characteristics

Human Machine Interface – HMI

Navigation is similar to the logic used in cell phones, with the option of sequential access to the parameters or through the groups (Menu) by means of the function access keys on the display (soft keys).



pictures for illustrative purposes only

Functions

- Power supply overvoltage and undervoltage programmable protections, voltage unbalance between phases of the power supply
- Motor overload and underload programmable protections
- Motor thermal protections
- Actuation of the programmable protections between fault or alarm
- Indication of:
 - motor current per phase, motor current as % of SSW rated current and as % of motor nominal current
 - power supply input voltages per phase
 - motor active and apparent power in kW and kVA
 - value of the analog inputs
 - status of the digital inputs and outputs
 - status of the thermal class protection
 - temperature of the SCRs
 - motor temperature using the accessory module for measuring temperature IOE
 - hours energized, hours in operation, hours fan use
 - ground fault current or voltage
 - Fault and alarm indication
- Fault history:
 - saving of the 10 last faults
 - date and time of fault occurrence
 - motor current in the fault event
 - power supply voltage in the fault event
 - SSW7000 operating status in the fault event
- Start and full duty diagnosis:
 - maximum starting current
 - average starting current
 - real starting time
 - maximum current at full duty
 - Power supply maximum and minimum voltage with the motor activated
 - Power supply maximum and minimum frequency with the motor activated
 - maximum number of starts per hour
 - total number of starts
 - maximum temperature of the SCRs
 - maximum temperatures of the motor (with the use of the IOE accessory)
- Flexible selection of start and stop control type, enabling: Ramp Voltage, Constant or in Ramp Current Limitation, Pump Control and -Constant Torque Control, Linear or Quadratic load starting
- Flexible Torque Control with extremely high performance
- Possibility to monitor the measurements of power supply voltages via Serial or Fieldbus communication
- Monitoring and programming in graphical mode using SuperDriveG2 Software
- Soft PLC allows implementation of PLC software or special operating versions of SSW7000 soft-starter.

Applications



Advantages

pictures for illustrative purposes only

- Flexible Torque control
- Overload capacity of 450% for 30 s. (2x / hour duty cycle)
- Management of Demand restrictions by the electric company
- Bumpless starting
- Motor protection
- Mechanical wear reduction
- Handles lower inrush current limitations of power supply

Product Code

1	2	3	4	5	6	7	8	9	10	11
SSW7000	A	300	T	6	22	41	F	-	-	-

1 - WEG medium voltage soft-starter

Series 7000

2 - Frame Size

<input type="text" value="A"/>	size A
<input type="text" value="N"/>	size N

3 - Rated Output Current

2300 Vca	4160 Vca	6900 Vca
180 = 180 A	180 = 180 A	180 = 180 A
300 = 300 A	300 = 300 A	300 = 300 A
360 = 360 A	360 = 360 A	360 = 360 A

4 - Power Supply

Three-phase

5 - Rated Voltage

<input type="text" value="2"/>	2.3 kV
<input type="text" value="4"/>	4.16 kV
<input type="text" value="6"/>	6.9 kV

6 - Single-Phase Auxiliary Power Supply

<input type="text" value="11"/>	110 Vac
<input type="text" value="22"/>	220 Vac

7 - Protection Degree

<input type="text" value="00"/>	IPO0 (Kits) (*1)
<input type="text" value="41"/>	IP41
<input type="text" value="N2"/>	NEMA 12

8 - Forced Ventilation

<input type="text" value="F"/>	Forced
<input type="text" value="(blank)"/>	Standard

9 - Special Hardware

Standard

10 - Special Hardware

Standard

11 - Market

Global

Note: (*1) Under request

Specification

Size A

SSW7000 Medium Voltage Soft-Starter								
Power Supply		Code	Output Rated Current	Size	Protection Degree	Single-Phase Auxiliary Power Supply	Motor maximum power (*2)	
							HP	kW
2300 Vac	Three-phase	SSW7000A180T22241	180 A	A	IP41	220 Vac	750	550
		SSW7000A180T21141				110 Vac	750	550
		SSW7000A300T22241	300 A			220 Vac	1350	1000
		SSW7000A300T21141				110 Vac	1350	1000
		SSW7000A360T22241	360 A			220 Vac	1500	1100
		SSW7000A360T21141				110 Vac	1500	1100
4160 Vac	Three-phase	SSW7000A180T42241	180 A	A	IP41	220 Vac	1500	1100
		SSW7000A180T41141				110 Vac	1500	1100
		SSW7000A300T42241	300 A			220 Vac	2500	1900
		SSW7000A300T41141				110 Vac	2500	1900
		SSW7000A360T42241	360 A			220 Vac	3000	2250
		SSW7000A360T41141				110 Vac	3000	2250
6900 Vac	Three-phase	SSW7000A180T62241	180 A	A	IP41	220 Vac	2500	1900
		SSW7000A180T61141				110 Vac	2500	1900
		SSW7000A300T62241	300 A			220 Vac	3700	2800
		SSW7000A300T61141				110 Vac	3700	2800
		SSW7000A360T62241	360 A			220 Vac	4500	3400
		SSW7000A360T61141				110 Vac	4500	3400

Note: (*2) The motor power rates above are meant for loads with normal overload, e.g. centrifugal pumps and compressors, based on WEG 4-pole 60-Hz motors. For applications with heavy duty overloads or other more severe conditions, contact WEG's sales force. The dimensioning of the SSW7000 must be calculated based on the information of the load curve, number of starts per hour and load type.

Specification

Size N

SSW7000 Medium Voltage Soft-Starter								
Power Supply	Code	Output Rated Current	Size	Protection Degree	Single-Phase Auxiliary Power Supply	Motor maximum power ⁽²⁾		
						HP	kW	
2300 Vac	Three-phase	SSW7000A180T222N2	180 A	N	NEMA 12	220 Vac	750	550
		SSW7000A180T211N2				110 Vac	750	550
		SSW7000A300T222N2	300 A			220 Vac	1350	1000
		SSW7000A300T211N2				110 Vac	1350	1000
		SSW7000A360T222N2	360 A			220 Vac	1500	1100
		SSW7000A360T211N2				110 Vac	1500	1100
4160 Vac	Three-phase	SSW7000A180T422N2	180 A	N	NEMA 12	220 Vac	1500	1100
		SSW7000A180T411N2				110 Vac	1500	1100
		SSW7000A300T422N2	300 A			220 Vac	2500	1900
		SSW7000A300T411N2				110 Vac	2500	1900
		SSW7000A360T422N2	360 A			220 Vac	3000	2250
		SSW7000A360T411N2				110 Vac	3000	2250

Note: (2*) The motor power rates above are meant for loads with normal overload, e.g. centrifugal pumps and compressors, based on WEG 4-pole 60-Hz motors. For applications with heavy duty overloads or other more severe conditions, contact WEG's sales force. The dimensioning of the SSW7000 must be calculated based on the information of the load curve, number of starts per hour and load type.

Accessories

Reference	Description	Slot
Control accessories to install in Slots 1, 2 and 3		
IOE-04	Module for 8 temperature sensors PT100	1 e 2
RS485-01	RS-485 serial communication module (Modbus)	3
RS232-01	RS-232C serial communication module (Modbus)	
RS232-02	RS-232C serial communication module with switch to program the microcontroller FLASH memory	
Anybus-CA Accessories to install in Slots 4		
PROFDP-05	ProfibusDP interface module	4
DEVICENET-05	Devicenet interface module	
ETHERNET/IP-05	EtherNet/IP interface module	
RS232-05	RS-232 interface module (passive) (Modbus)	
RS485-05	RS485 interface module (passive) (Modbus)	
Flash Memory Module to install in Slot 5 – Included in Standard Models		
MMF-01	FLASH memory module	5
Other Accessories		
HMI-01	Man Machine Interface – MMI (sold separately) ⁽¹⁾	-
RHMIF-01	Frame kit for MMI (protection rate IP56)	
TC FT	Ground fault CT	

Block Diagram

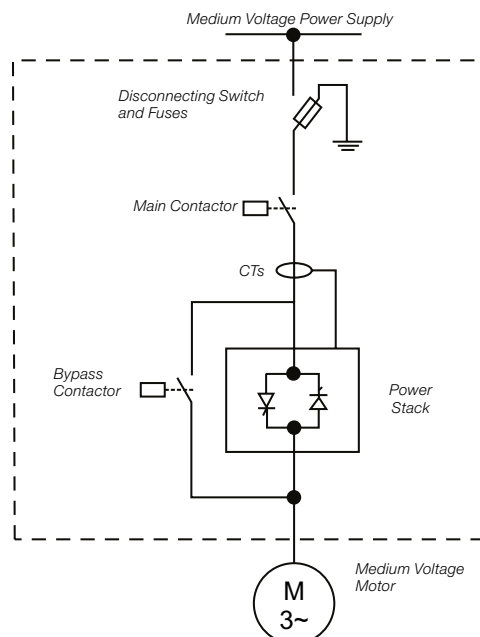

Dimensions



pictures for illustrative purposes only

Sizes	Width mm (inch)	Height mm (inch)	Depth mm (inch)	Weight (w/ power stacks) kg (lb)
A	1200 (47.2)	2365 (93)	1007 (39.6)	970 (2140)
N	1072 (42.2)	2365 (93)	845 (33.3)	970 (2140)

Power stacks

Rated Voltage	Width mm (inch)	Height mm (inch)	Depth mm (inch)	Weight kg (lb)
2.3 kV	262 (10.3)	772 (28.4)	430 (16.9)	53.0 (117)
4.16 kV	262 (10.3)	772 (28.4)	546 (21.5)	68.6 (151)
6.9 kV	262 (10.3)	772 (28.4)	664 (26.1)	83.3 (184)

Standards

ANSI/IEEE C37.2	Function/Protection Feature	Standard	Option
		<input type="checkbox"/>	<input type="checkbox"/>
19	Reduced Voltage Starting and Bypass	<input type="checkbox"/>	<input type="checkbox"/>
27	Undervoltage protection	<input type="checkbox"/>	<input type="checkbox"/>
37	Undercurrent protection	<input type="checkbox"/>	<input type="checkbox"/>
46	Phase-Balance Current protection	<input type="checkbox"/>	<input type="checkbox"/>
47	Phase Sequence	<input type="checkbox"/>	<input type="checkbox"/>
48	Incomplete Sequence	<input type="checkbox"/>	<input type="checkbox"/>
50	Instantaneous Overcurrent trip	<input type="checkbox"/>	<input type="checkbox"/>
51	Overcurrent trip	<input type="checkbox"/>	<input type="checkbox"/>
55	Power Factor check	<input type="checkbox"/>	<input type="checkbox"/>
59	Overvoltage	<input type="checkbox"/>	<input type="checkbox"/>
81	Frequency check	<input type="checkbox"/>	<input type="checkbox"/>
86	Lockout Relay - electronic	<input type="checkbox"/>	<input type="checkbox"/>
50N/51G	Ground fault detection instantaneous and fault-current	<input type="checkbox"/>	<input type="checkbox"/>
49 & 38	Winding Temperature and Bearing Temperature	<input type="checkbox"/>	<input type="checkbox"/>



Technical specifications

Power Supply	Power Voltage (R/1 L1, S/3L2,T/5L3)	Low voltage test: 500Vac: (-60% to +10%) or (200 to 550Vac) Models: 2300Vac: (-60% to +10%) or (920 to 2530Vac) 4160Vac: (-60% to +10%) or (2760 to 4576Vac) 6900Vac: (-60% to +10%) or (2760 to 7590Vac)
	Frequency	(50 to 60Hz): (±10%) or (45 to 66Hz)
Capacity	Maximum number of starts	5 starts in 2 hours (One start every 30 minutes)
	Start cycle	AC-53a; 4.5-30:50-2
Thyristors	Medium voltage SCRs per power stack	2300Vac: 2 thyristors per per power stack 4160Vac: 2 coupled pairs of thyristors 6900Vca: 2 coupled triplets of thyristors
	Peak reverse voltage on the power stack	2300Vac: 6.5kV 4160Vac: 13kV 6900Vac: 19.5kV
Protections	Protection by Hardware	dv/dt filter Active overvoltage protection on the thyristors
Control Supply	Control voltage	As per code of the SSW7000: 110Vac: (-15% to 10%) or (93.5 to 121Vac) 230Vac: (-15% to 10%) or (195.6 to 253Vac)
	Frequency	(50 to 60Hz): (±10%) or (45 to 66Hz)
	Consumption	Continuous: 900 mA Peak: 9.5 A (during the closing of the vacuum contactors)
Control	Method	Voltage ramp. Current limitation. Pump control. Torque control. Current ramp.
Inputs	Digital	6 insulated digital inputs, 24 Vdc, programmable functions
	Analog	2 differential inputs insulated by differential amplifier; AI1 resolution: 12 bits, AI2 resolution: 11bits + signal, (0 to 10) V, (0 to 20) mA or (4 to 20) mA, Impedance: 400kQ for (0 to 10V), 500Q for (0 to 20mA) or (4 to 20mA), programmable functions
Outputs	Digital	3 NO/NC contact relays, 240 Vac, 1A, programmable functions.
	Analog	2 insulated outputs, (0 to 10V) RL ± 10kQ (maximum load), 0 to 20mA or 4 to 20mA RL<500Q, 11-bit resolution, programmable functions
Man Machine Interface	Standard	9 keys: Turn/Stop, Increase, Decrease, Rotation Direction, Jog, Local/Remote, right Soft key and left Soft key. Graphic LCD. It enables access to/change of all parameters.
Safety	Main protections	Under and Overcurrent and current unbalance. Under and Overvoltage and voltage unbalance. Under and Overtorque and Active overpower Phase loss. Reverse phase sequence Overtemperature in the power racks. Motor overload. Motor overtemperature (optional). External defect. Ground fault by voltage or current. Fault in the power racks. Fault in the power contactors. Faults in the control boards. Communication faults of MMI and between controls. Faults in the communication networks. Programming errors. For further details and more protections implemented, refer to the programming manual.
Protection degree	IP41	Standard panel
PC connection for programming	USB Connector	USB standard Rev. 2.0 (basic speed). USB plug type B "device". Interconnecting Cable: standard host/device shielded USB cable
Environmental Conditions	Temperature	-10° a 40°C
	Altitude	Up to 1000 m above sea level. For higher altitudes, contact our sales force.
	Humidity	Air relative humidity of 5 % to 90 % non-condensing.
Standards	NBR IEC 62271-200	High voltage controlgear and switchgear - part 200: High voltage controlgear and switchgear in metal enclosure for voltages over 1 kV up to and including 52 kV
	IEC 62271-1	High-voltage switchgear and controlgear - Part 1: Common specifications
	IEC 60060-1	High-voltage test techniques. Part 1: General definitions and test requirements
	CISPR 11	Industrial, scientific and medical (ISM) radio-frequency equipment - electromagnetic disturbance characteristics - limits and methods of measurement
	IEC 61000-4-4	Electromagnetic compatibility (EMC) - Part 4: testing and measurement techniques - section 4: electrical fast transient/burst immunity test. Basic EMB publication
	IEC 61000-4-18	Electromagnetic compatibility (EMC) - Part 4-18: testing and measurement techniques - damped oscillatory wave immunity test
	NBR IEC 60529	Protection rates for electric equipment enclosures (ip code)
	UL 347	Medium Voltage AC Contactors, Controllers and Control Centers
UL 347B	Medium Voltage Motor Controllers	

WEG Worldwide Operations

ARGENTINA

WEG EQUIPAMIENTOS
ELECTRICOS S.A.
(Headquarters San
Francisco-Cordoba)
Sgo. Pampiglione 4849
Parque Industrial San Francisco
2400 - San Francisco
Phone: +54 (3564) 421484
Fax: +54 (3564) 421459
info-ar@weg.net
www.weg.net/ar

AUSTRALIA

WEG AUSTRALIA PTY. LTD.
3 Dalmore Drive
Carribean Park Industrial Estate
Scoresby VIC 3179 - Melbourne
Phone: 61 (3) 9765 4600
Fax: 61 (3) 9753 2088
info-au@weg.net
www.weg.net/au

BELGIUM

WEG BENELUX S.A.
Rue de l'Industrie 30 D,
1400 Nivelles
Phone: + 32 (67) 88-8420
Fax: + 32 (67) 84-1748
info-be@weg.net
www.weg.net/be

CHILE

WEG CHILE S.A.
Los Canteros 8600
La Reina - Santiago
Phone: (56-2) 784 8900
Fax: (56-2) 784 8950
info-cl@weg.net
www.weg.net/cl

CHINA

WEG (NANTONG) ELECTRIC
MOTOR MANUFACTURING CO.,
LTD.
No. 128# - Xinkai South Road,
Nantong Economic &
Technical Development Zone,
Nantong, Jiangsu Province.
Phone: (86) 0513-85989333
Fax: (86) 0513-85922161
info-cn@weg.net
www.weg.net/cn

COLOMBIA

WEG COLOMBIA LTDA
Calle 46A N82 - 54
Portería II - Bodega 7 - San
Cayetano II - Bogotá
Phone: (57 1) 416 0166
Fax: (57 1) 416 2077
info-co@weg.net
www.weg.net/co

DENMARK

WEG SCANDINAVIA DENMARK
Sales Office of WEG
Scandinavia AB
Anelysparken 43B
True
8381 Tilst - Denmark
Phone: +45 86 24 22 00
Fax : +45 86 24 56 88
info-se@weg.net
www.weg.net/se

FRANCE

WEG FRANCE SAS
ZI de Chenes - Le Loup
13 Rue du Morellon - BP 738
38297 Saint Quentin Fallavier
Phone: +33 (0) 4 74 99 11 35
Fax: +33 (0) 4 74 99 11 44
info-fr@weg.net
www.weg.net/fr

GERMANY

WEG GERMANY GmbH
Industriegebiet Türnich 3
Geigerstraße 7
50169 Kerpen-Türnich
Phone: +49 (0)2237/9291-0
Fax: +49 (0)2237/9292-200
info-de@weg.net
www.weg.net/de

GHANA

ZEST ELECTRIC GHANA
LIMITED - WEG Group
15, Third Close Street Airport
Residential Area, Accra PMB CT
175, Cantonments
Phone: 233 30 27 664 90
Fax: 233 30 27 664 93
info@zestghana.com.gh
www.zestghana.com.gh

INDIA

WEG ELECTRIC (INDIA) PVT.
LTD.
#38, Ground Floor, 1st Main
Road, Lower Palace Orchards,
Bangalore - 560 003
Phone(s): +91-80-4128 2007
+91-80-4128 2006
Fax: +91-80-2336 7624
info-in@weg.net
www.weg.net/in

ITALY

WEG ITALIA S.R.L.
V.le Brianza 20 - 20092 - Cinisello
Balsamo - Milano
Phone: (39) 02 6129-3535
Fax: (39) 02 6601-3738
info-it@weg.net
www.weg.net/it

JAPAN

WEG ELECTRIC MOTORS
JAPAN CO., LTD.
Yokohama Sky Building 20F,
2-19-12 Takashima,
Nishi-ku, Yokohama City,
Kanagawa, Japan 220-001
Phone: (81) 45 440 6063
info-jp@weg.net
www.weg.net/jp

MEXICO

WEG MEXICO, S.A. DE C.V.
Carretera Jorobas-Tula Km. 3.5,
Manzana 5, Lote 1
Fraccionamiento Parque
Industrial - Huehuetoca,
Estado de México - C.P. 54680
Phone: + 52 (55) 5321 4275
Fax: + 52 (55) 5321 4262
info-mx@weg.net
www.weg.net/mx

NETHERLANDS

WEG NETHERLANDS
Sales Office of
WEG Benelux S.A.
Hanzepoort 23C
7575 DB Oldenzaal
Phone: +31 (0) 541-571080
Fax: +31 (0) 541-571090
info-nl@weg.net
www.weg.net/nl

PORTUGAL

WEG EURO - INDÚSTRIA
ELÉCTRICA, S.A.
Rua Eng. Frederico Ulrich
Apartado 6074
4476-908 - Maia
Phone: +351 229 477 705
Fax: +351 229 477 792
info-pt@weg.net
www.weg.net/pt

RUSSIA

WEG RUSSIA
Russia, 194292, St. Petersburg,
Prospekt Kultury 44, Office 419
Phone: +7(812)363-21-72
Fax: +7(812)363-21-73
info-ru@weg.net
www.weg.net/ru

SOUTH AFRICA

ZEST ELECTRIC MOTORS
(PTY) LTD. WEG Group
47 Galaxy Avenue, Linbro
Business Park - Gauteng Private
Bag X10011 - Sandton, 2146
Johannesburg
Phone: (27-11) 723-6000
Fax: (27-11) 723-6001
info@zest.co.za
www.zest.co.za

SPAIN

WEG IBERIA S.L.
Avenida de la Industria,25
28823 Coslada - Madrid
Phone: (34) 916 553 008
Fax : (34) 916 553 058
info-es@weg.net
www.weg.net/es

SINGAPORE

WEG SINGAPORE PTE LTD
159, Kampong Ampat,
#06-02A KA PLACE.
Singapore 368328.
Phone: +65 6858 9081
Fax: +65 6858 1081
info-sg@weg.net
www.weg.net/sg

SWEDEN

WEG SCANDINAVIA AB
Box 10196
Verkstadgatan 9
434 22 Kungsbacka
Phone: (46) 300 73400
Fax: (46) 300 70264
info-se@weg.net
www.weg.net/se

UK

WEG ELECTRIC
MOTORS (U.K.) LTD.
28/29 Walkers Road
Manorside Industrial Estate
North Moons Moat - Redditch
Worcestershire B98 9HE
Phone: 44 (0)1527 596-748
Fax: 44 (0)1527 591-133
info-uk@weg.net
www.weg.net/uk

UNITED ARAB EMIRATES

WEG MIDDLE EAST FZE
JAFZA - JEBEL ALI FREE ZONE
Tower 18, 19th Floor,
Office LB 18 1905
P.O. Box 262508 - Dubai
Phone: +971 (4) 8130800
Fax: +971 (4) 8130811
info-ae@weg.net
www.weg.net/ae

USA

WEG ELECTRIC CORP.
6655 Sugarloaf Parkway,
Duluth, GA 30097
Phone: 1-678-249-2000
Fax: 1-770-338-1632
info-us@weg.net
www.weg.net/us

VENEZUELA

WEG INDUSTRIAS VENEZUELA C.A.
Avenida 138-A
Edificio Torre Banco Occidental de
Descuento, Piso 6 Oficina 6-12
Urbanización San Jose de Tarbes
Zona Postal 2001
Valencia, Edo. Carabobo
Phone(s): (58) 241 8210582
(58) 241 8210799
(58) 241 8211457
Fax: (58) 241 8210966
info-ve@weg.net
www.weg.net/ve



WEG Equipamentos Elétricos S.A.
International Division
Av. Prefeito Waldemar Grubba, 3000
89256-900 - Jaraguá do Sul - SC - Brazil
Phone: 55 (47) 3276-4002
Fax: 55 (47) 3276-4060
www.weg.net

