

HGP Part Number	HorsePower (HP)	kVar	Maximum Amps (A)	Harmonic	Voltage (V)	Hz.	Phase
HGP0500AW3----	500	150	590	5th	480	60	3

Note: For Torque Information See IOM Manual

Customer Connections:
L1, L2, L3, T1, T2, T3, and Ground Lug.
Wire Range- Two, 600MCM-2AWG

HGP Part Number	Schematic Drawing #	Approx Weight (LBS)
HGP0500AW3S0000	28697-5S	1000
HGP0500AW3C0000	28697-5	1019
HGP0500AW3C0000H	29597-H	1024
HGP0500AW3S1000	29597-PQ1	1003
HGP0500AW3C1000	29597-PQ	1022
HGP0500AW3C100H	29597-PCH	1026

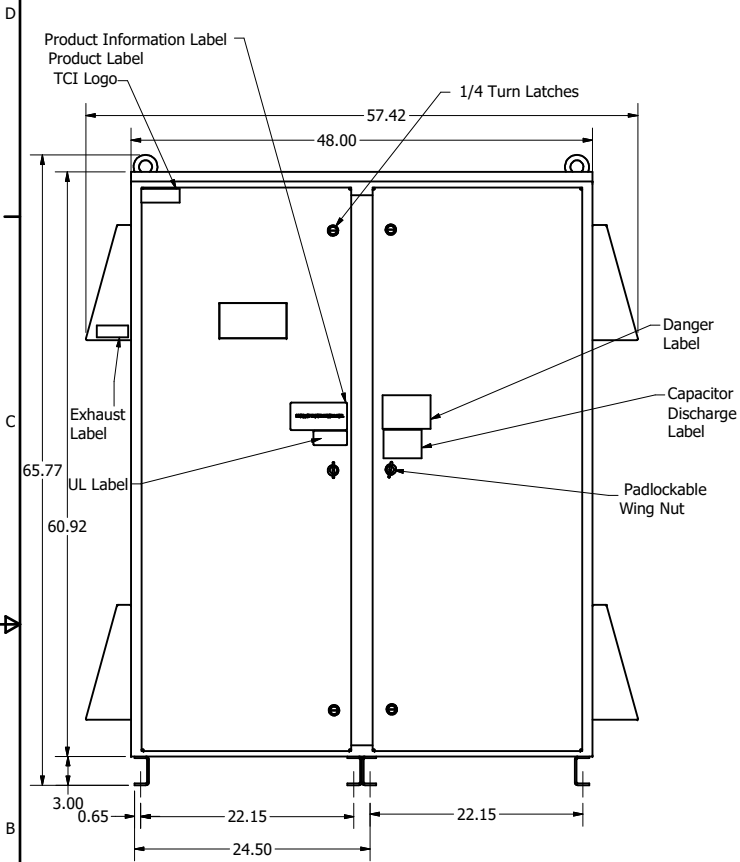

Front View With Door

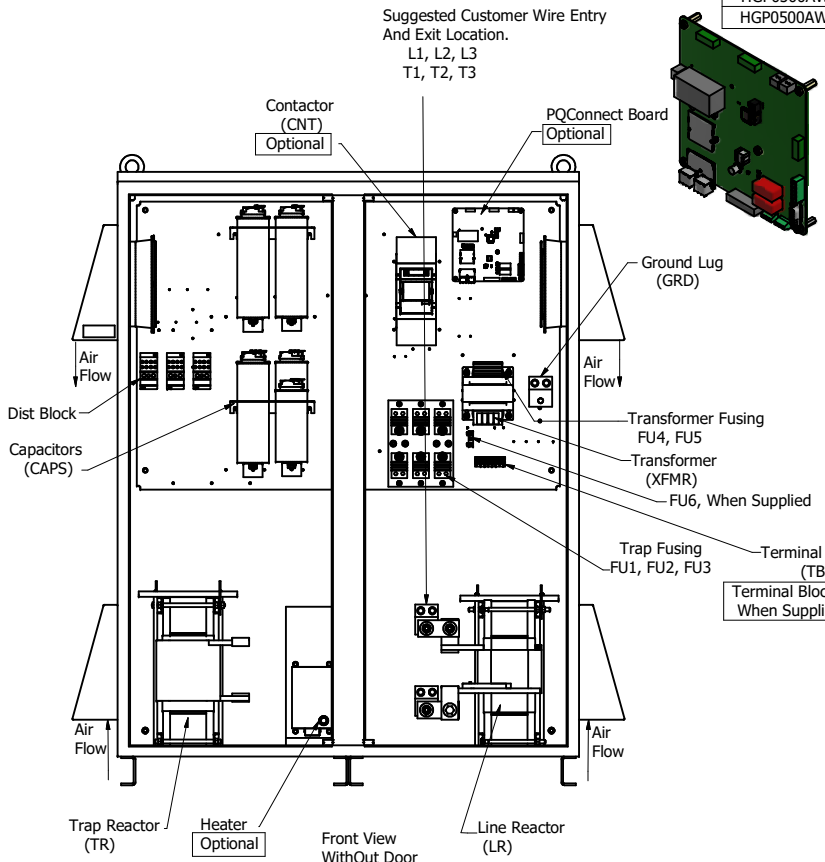

Front View WithOut Door

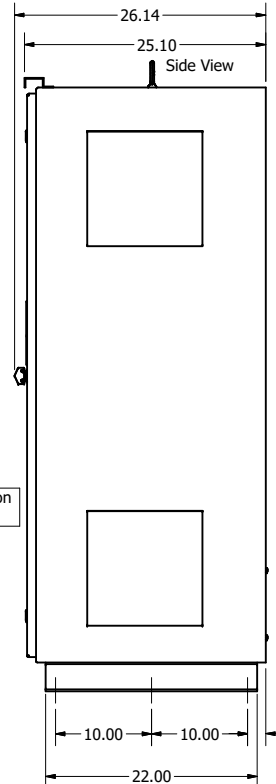

Side View

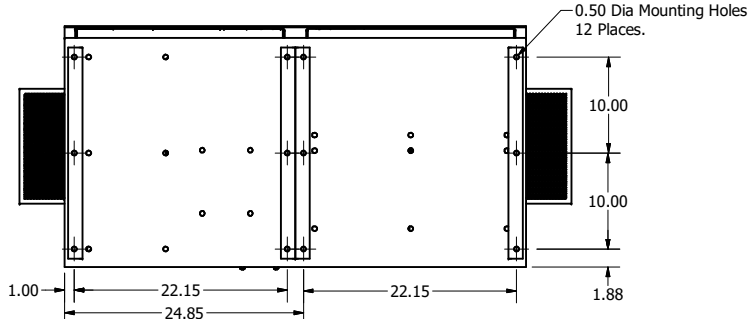

Bottom Of Enclosure

HGP0500AW3----						
Components	S0000	C0000	C000H	S1000	C1000	C100H
Line Reactor (LR)	x	x	x	X	X	X
Trap Reactor (TR)	x	x	x	X	X	X
Capacitor (Cap)	x	x	x	X	X	X
Trap Fusing, FU1, FU2, FU3	x	x	x	X	X	X
Contactor (CNT)		x	x		X	X
Transformer (XFMR)	x	x	x	X	X	X
XFMR Fusing, FU4, FU5	x	x	x	X	X	X
Heater			x			X
PQConnect Board				X	X	X

Customer Is Responsible For Installation to Meet All National And Local Electrical Codes.

NOTE: USE ONLY HUBS OR FITTINGS THAT COMPLY WITH UL514B FOR TYPE 3R ENCLOSURES

Material(s) Shall be RoHS Compliant

THE INFORMATION AND DESIGNS CONTAINED IN THIS DRAWING ARE CONFIDENTIAL AND THE PROPRIETARY PROPERTY OF ALLIED MOTION TECHNOLOGIES INC. AND ITS SUBSIDIARIES. NEITHER THIS DESIGN NOR ANY INFORMATION CONTAINED IN THIS DRAWING MAY BE REPRODUCED OR DISCLOSED TO OTHERS WITHOUT THE EXPRESS WRITTEN CONSENT OF ALLIED MOTION TECHNOLOGIES INC. AND ITS SUBSIDIARIES.

NO	REVISION	DATE	BY	SCALE
K	5636, GE to ABB CNT Update	1/31/2022	DSW	
J	5454, Schematic Updates	11/18/2020	DSW	
I	5388 Updated CNT Connections	9/15/20	JRN	
H	4983, Update Layout	11/25/19	DSW	
NO				

TOLERANCES (EXCEPT AS NOTED)	
DECIMAL	.XX ± .25 .XXX ± .10
FRACTIONAL	± 1/16
ANGULAR	± 1°

TCI W182N10611 (Rev 11/16)
Germano, WI 53012 © 2022 TCI, LLC

An Official Motion Group Company

HarmonicGuard Passive, HGP0500AW3----

HGP, 500HP, 480/3/60, Type 3R

105570DG

SCALE: 1/8 DATE: 4/29/14

REV: 1/8

SHT. 1 OF 1