

HP	Volts	Phase	Hz	Harmonic	Kvar	Contactors	PQconnect	Weight (lb)	Terminal Hole Size (In)
700	480 & 600	3	60	5th	210	Without	Without	1270	0.44 Dia
700	480 & 600	3	60	5th	210	With	Without	1285	0.44 Dia
700	480 & 600	3	60	5th	210	With	With	1295	0.44 Dia
800	480 & 600	3	60	5th	240	Without	Without	1270	0.44 Dia
800	480 & 600	3	60	5th	240	With	Without	1285	0.44 Dia
800	480 & 600	3	60	5th	240	With	With	1295	0.44 Dia
900	480 & 600	3	60	5th	270	Without	Without	1340	0.56 Dia
900	480 & 600	3	60	5th	270	With	Without	1355	0.56 Dia
900	480 & 600	3	60	5th	270	With	With	1365	0.56 Dia
1000	480 & 600	3	60	5th	300	Without	Without	1340	0.56 Dia
1000	480 & 600	3	60	5th	300	With	Without	1355	0.56 Dia
1000	480 & 600	3	60	5th	300	With	With	1365	0.56 Dia

Enclosure	"A" Dim	"B" Dim	"C" Dim
Type 1	41.62	3.0	2.53
Type 3R	47.0	8.6	5.4

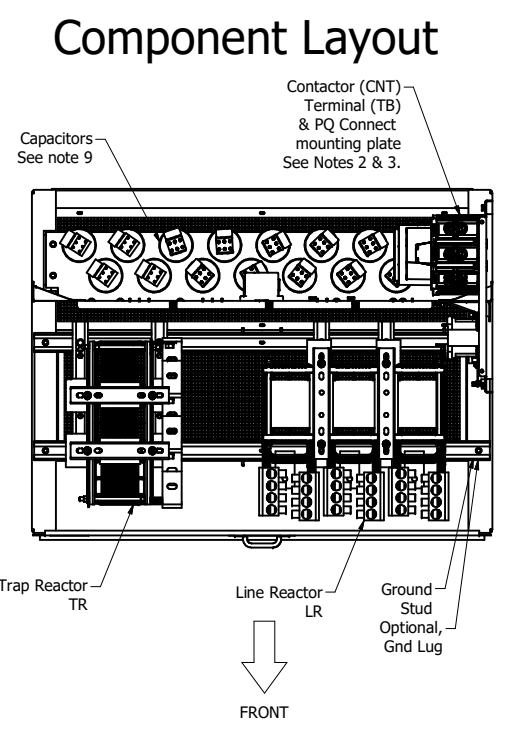
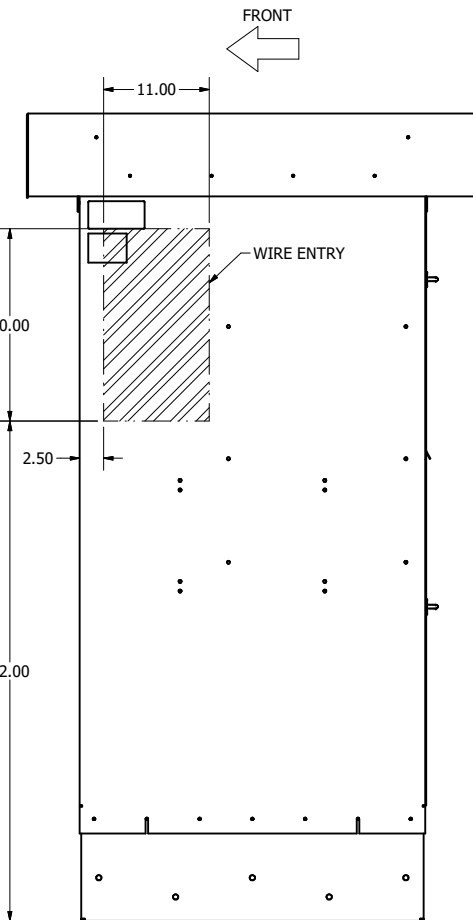
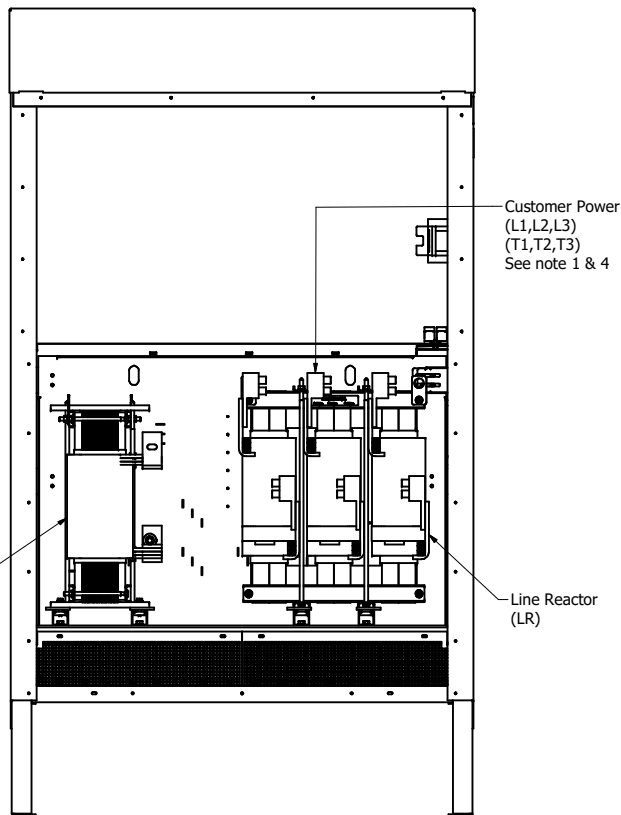
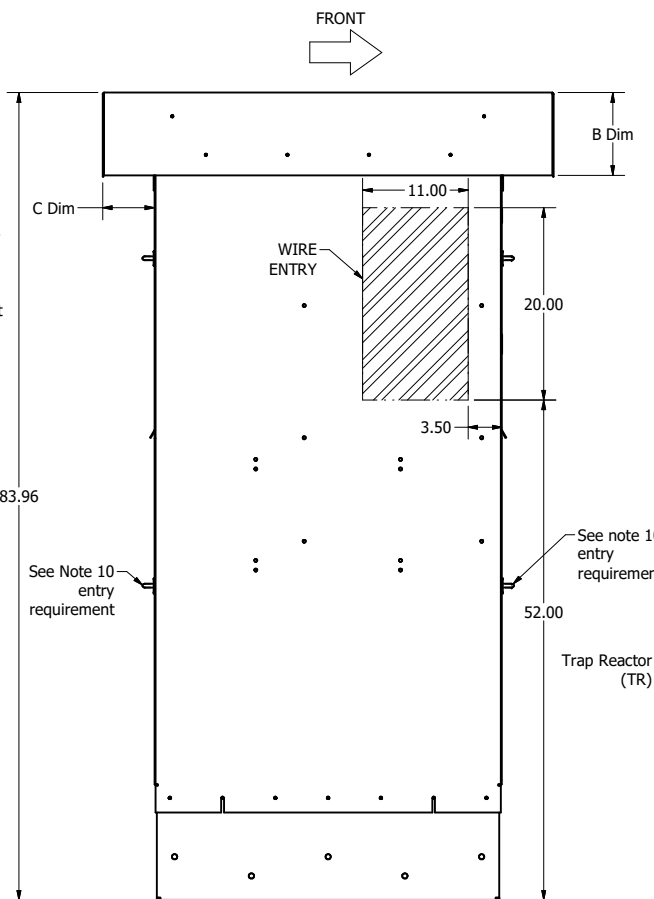
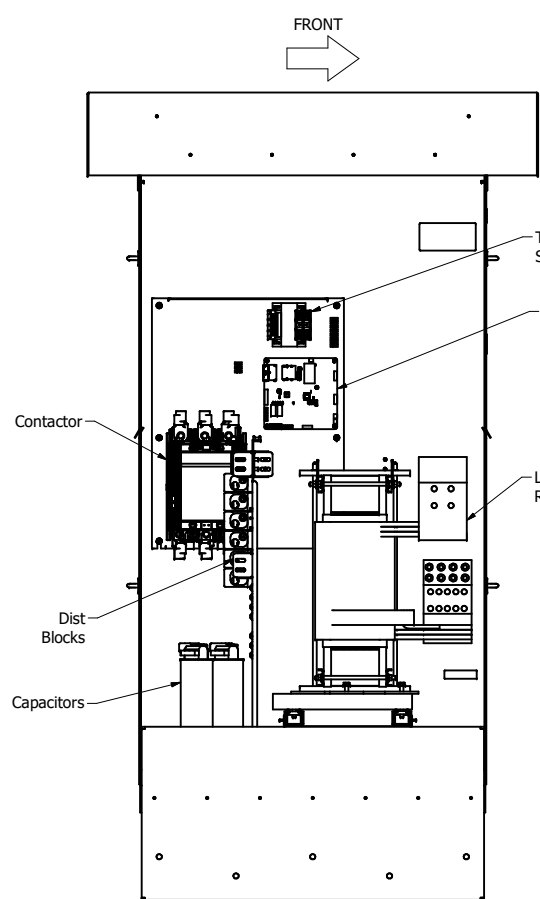

- 1.) Refer to manual for wire size and torque.
- 2.) Contactor (CNT) and terminal (TB) are optional.
- 3.) PQconnect with Transformer is optional.
- 4.) Refer to schematic # 30047, PQconnect option schematic #30047-PQ
- 5.) Preferred bottom wire entry area.
- 6.) Enclosure is shown with a Type 3R top.
- 7.) Use only hubs or fittings that comply with UL514B for Type 3R applications
- 8.) Installation must meet all national and local codes.
- 9.) Number, size & location can vary per Hp and voltage.
- 10.) Service access entry through lower front and rear panel is required.

THE INFORMATION AND DESIGNS CONTAINED IN THIS DRAWING ARE CONFIDENTIAL AND THE PROPRIETARY PROPERTY OF ALLIED MOTION TECHNOLOGIES INC. AND ITS SUBSIDIARIES. NEITHER THIS DESIGN NOR ANY INFORMATION CONTAINED IN THIS DRAWING MAY BE REPRODUCED OR DISCLOSED TO OTHERS WITHOUT THE EXPRESS WRITTEN CONSENT OF ALLIED MOTION TECHNOLOGIES INC. AND ITS SUBSIDIARIES.

NO	REVISION	DATE	BY	SCALE	DATE	BY	SCALE
		11/15/21	MJS	1:1	11/15/21	MJS	1:1

TOLERANCES (UNLESS NOTED)  
 DECIMAL .XX ± .03  
 .XXX ± .010  
 FRACTIONAL ± 1/32  
 ANGULAR ± .1°

As Designed

HarmonicShield  
 700HP to 1000HP, 480 & 600 Volt  
 108310DG

W132N10G11 (Rev 1) 1/24/20  
 Germantown, WI 53022  
 © 2021 TCI, LLC

SHEET 1 OF 1