

480 Rated Voltage, 600 Max Voltage, High Z, Impedance.									
Part Number	Horsepower (HP)	Motor Amps (A)	Maximum Amps (A)	Inductance (uH)	Weight (LBS)	Losses (W)	Available Lug Kit	Terminal Hole Size (Inches)	Revision
KDRJ1H	200	240	240	126	75	420	SLK12	0.44	A

480 Rated Voltage, 600 Max Voltage, Output									
Part Number	Horsepower (HP)	Motor Amps (A)	Maximum Amps (A)	Inductance (uH)	Weight (LBS)	Available Lug Kit	Optional Lug Kit Available	Terminal Hole Size (Inches)	Revision
KDRJ1P	250	302	310	38.2	70	SLK12	SLK13	0.56	B

575 Rated Voltage, 600 Max Voltage, Output									
Part Number	Horsepower (HP)	Motor Amps (A)	Maximum Amps (A)	Inductance (uH)	Weight (LBS)	Losses (W)	Available Lug Kit	Terminal Hole Size (Inches)	Revision
KDRJ31P	300	289	300	38.8	70	216	SLK12	0.44	A

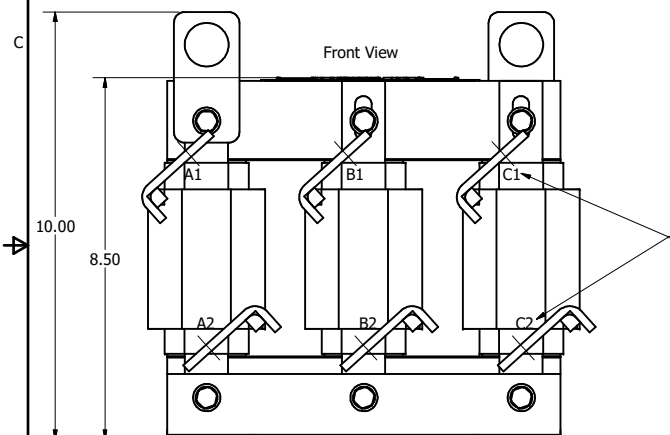

(Customer Connections) Markings On Coils For Reference Only.

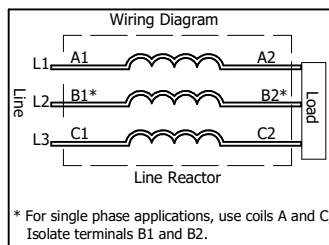
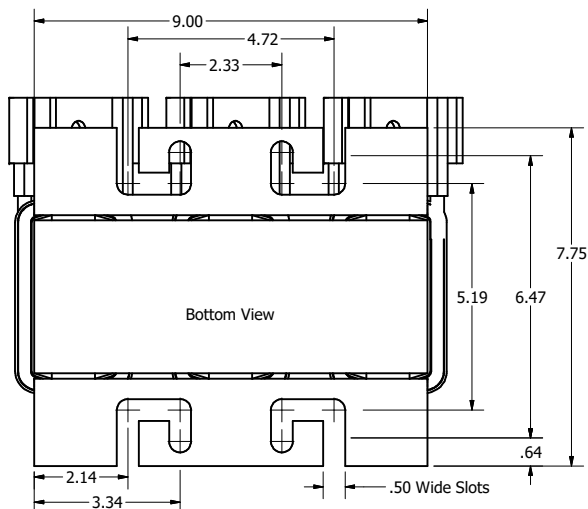
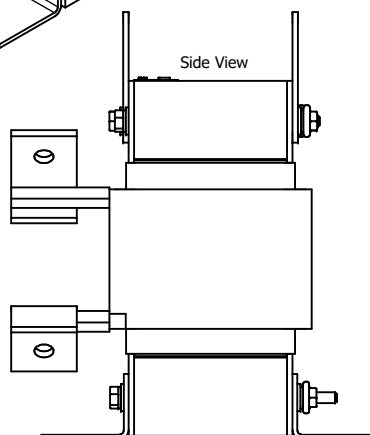

**TCI** (800) 824-8282 [transcoil.com](http://transcoil.com)

**KDRUL Drive Reactor**  
 KDR- Motor Amps ---  
 3PH, 480V Max, -A Max, 600V Max, -A Max  
 480 Amps Max, 150C Rise, Test  
 Manual #30895 LUG KIT #SLK---

UL LISTED CE  
 2ND QUART. 1999

DATE CODE: A1 B1 C1

- Notes:
1. KDR Lug Kits sold separately. Contact TCI.
  2. For KDRUL Version With Terminal Lugs Attached, See Sheet 2
  3. UL file number: cULus Listed File E116124.
  4. KDR Drive Reactors Comply With The Thermal and Altitude Standards Set Forth by NEMA ST20-1992.
  5. KDR IOM Manual Part Number 30895
  6. NEC Current For 208/240 Volts, Horsepower Based On 208 Volts.
  7. Material(s) Shall be RoHS Compliant
  8. Customer Is Responsible For Installation To Meet All National And Local Electrical Codes.

THE INFORMATION AND DESIGNS CONTAINED IN THIS DRAWING ARE CONFIDENTIAL AND THE PROPRIETARY PROPERTY OF ALLIED MOTION TECHNOLOGIES INC. AND ITS SUBSIDIARIES. NEITHER THIS DESIGN NOR ANY INFORMATION CONTAINED IN THIS DRAWING MAY BE REPRODUCED OR DISCLOSED TO OTHERS WITHOUT THE EXPRESS WRITTEN CONSENT OF ALLIED MOTION TECHNOLOGIES INC. AND ITS SUBSIDIARIES.

NO	REVISION	DATE	BY	TOLERANCES (EXCEPT AS NOTED)
B	5681, KDRJ1P Optional Lug Kit SLK13	8/5/2021	DSW	DECIMAL .XX ± .25 .XXX ± .10
A	Combined drawing	2/27/2018	DSW	FRACTIONAL ± 1/16
NO				ANGULAR ± 1°

**TCI** W132N10611 (Rev 11/16)  
 Germantown, WI 53022  
 © 2021 TCI, LLC  
 An Official Motors Company  
 KDR J Frame, Copper Bus  
 Reactor Drawing  
 DWN BY: DSW DATE: 2/27/2018 107536DG  
 SCALE: 1/2.2 DRAWN BY: DSW SHEET: 1 OF 3