

# INSTRUCTION MANUAL

## PWM Sine Wave Filters and L-C-L Filters for Active (IGBT) Front Ends



## Table of Contents

Topic	Section	Page
Safety Instructions	1	3
Prior to Installation	2	4
Theory of operation	3	5
Catalog Numbers & Product Selection	4	7
Applications for Sine Wave Filter	5	9
Transportation, handling and storage	6	11
Installation & connection	7	12
Specifications and Performance	8	24
Technical Data	9	27
Maintenance	10	34
Troubleshooting	11	35
Factory support	12	36

Note: Tolerance for dimensions is is  $\pm 0.20$  inches.

Note: Inductance tolerance is  $\pm 3\%$ ; Inductance is balanced between all three phases.

Note: Data is subject to change without notice.

	INSTALLATION, OPERATION AND MAINTENANCE MANUAL FOR LOW VOLTAGE PolyGap® Sinewave Filters	PSF-INSTR_006/210914 Rev_22-0909 Rev 23-0327
--	---------------------------------------------------------------------------------------------------	----------------------------------------------------

## 1.0 SAFETY INSTRUCTIONS



# !! CAUTION – High Voltage !!



**WARNING - THE EQUIPMENT COVERED BY THIS PUBLICATION MUST BE SELECTED FOR A SPECIFIC APPLICATION AND MUST BE INSTALLED, OPERATED AND MAINTAINED BY QUALIFIED PERSONNEL WHO ARE THOROUGHLY TRAINED AND WHO UNDERSTAND ANY HAZARDS WHICH MAY BE INVOLVED. THIS MANUAL HAS BEEN WRITTEN FOR SUCH QUALIFIED PERSONNEL EXCLUSIVELY AND IS NOT INTENDED TO BE A SUBSTITUTE FOR ADEQUATE TRAINING IN SAFETY PROCEDURES FOR THIS TYPE OF EQUIPMENT.**

**WARNING** – Only qualified electricians should handle the installation of this filter, otherwise electric shock or fire may occur.

**CAUTION** – Improper handling may cause mis-operation and reduce the life of the filter.

**CAUTION** – This manual should be given to the user of this product and should be kept in a safe place until the filter is removed from service.

**WARNING** – Disconnect all electrical power from the circuit into which the filter is being installed. Extreme caution must be taken to prevent contact with high voltage during installation, operation and service of this equipment. Accidental contact with high voltage can result in personal injury or death.

**WARNING** – This filter contains power capacitors which will store energy for a time period of up to five minutes following de-energization. Using a voltmeter, confirm that the capacitor has entirely discharged as evidenced by zero voltage present between the capacitor terminals prior to performing installation, operation or service procedures. Accidental contact with energized parts may cause personal injury or death.

**WARNING** - There can be several live parts inside the filter while power is applied. Disconnect all electrical power to the circuit before installing or servicing the filter. Accidental contact with energized parts may cause personal injury or death.

**WARNING** – Observe torque requirements for all electrical connections. When making connection using crimp terminals, be sure to use the crimping tools recommended by the terminal manufacturer. Wire and cable connections having improper torque may cause fire.

**WARNING** – The ground terminal should always be connected to the ground using a conductor which is the same diameter (gauge) as the phase conductor. Lack of ground connection or improper grounding may result in electric shock or fire.

**WARNING** - Install filter in accordance with all applicable local electrical standards (NEC, etc). Failure to properly install filter in accordance with local electrical safety standards may cause electric shock, fire or service disruption.

**WARNING** – Install filter in an enclosure that will prevent accidental contact with live parts and by using proper wire sizes as dictated by local electrical safety standards. Accidental contact with energized parts may cause personal injury or death.

**CAUTION** – Install filter in an enclosure that will prevent foreign matter such as paper, lint, wood chips, metallic chips from contact with live parts, otherwise fire, personal injury or equipment mis-operation may occur.

***We strongly recommend that the installation, operation and maintenance of this equipment be handled by an electrical engineer or technically qualified electrician with experience in electrical power equipment.***

	INSTALLATION, OPERATION AND MAINTENANCE MANUAL FOR LOW VOLTAGE PolyGap® Sinewave Filters	PSF-INSTR_006/210914 Rev_22-0909 Rev 23-0327
--	---------------------------------------------------------------------------------------------------	----------------------------------------------------

## 2.0 PRIOR TO INSTALLATION

This instruction manual is intended to serve the user as a general guide for the installation and maintenance of Mangoldt Sinewave Filters.

The instruction manual must be read completely and carefully before unpacking, installation and maintenance.

Mangoldt Sinewave Filters are designed and intended for use with variable frequency motor drives (VFD). They are selected based upon motor full load ampere (FLA) rating. They must always be used within their rated maximum ampere ratings. Confirm that the sinewave filter current rating is adequate to handle the motor full load current.

Proper filter selection must be determined by the customer based upon ratings of the load equipment and the operating characteristics of that equipment. Refer to the Sinewave Filter catalog for proper selection, or contact the factory technical support office for guidance in selection of filters for VFD/motors or other non-motor loads.

Note: In the event that the equipment will not be installed immediately after arrival, it should be placed in intermediate storage without removing the packing. In this case, the crates are to be stored on a level area of sufficient strength to bear their weight and in a clean and non-corrosive atmosphere. If the intermediate storage is outdoors the period of storage must be limited to approximately 6 months, depending on the atmospheric conditions.

### 3.0 Theory of operation

Mangoldt VFD PolyGap® Sinewave Filters are designed for use at the output of variable frequency drives (VFD) to convert the PWM voltage to a near sinewave voltage. Mangoldt Sinewave Filters allow fundamental frequency current to flow easily from the VFD to the motor but significantly attenuate those high frequencies associated with the VFD switching (carrier) frequency ( $f_{sw}$ ).

They may also be used to form a L-C-L filter for use at the grid side of grid tied inverter (drives with active front ends, renewable energy inverters) by adding a 5% impedance reactor (see Section 2.2)

Contact the factory technical support office for guidance in selection of filters for other types of loads including non-motor applications.

#### 3.1 VFD Output Sine wave Filters:

Mangoldt's standard PolyGap® Sinewave Filters are inductor-Capacitor (L-C) low pass filters which may be used in motor and non-motor applications. At the output side of a VFD, the PolyGap reactor impedes the flow of switching frequency (and its harmonics) current and together with the shunt capacitors forms a low pass filter that diverts these high frequencies away from the motor (load).

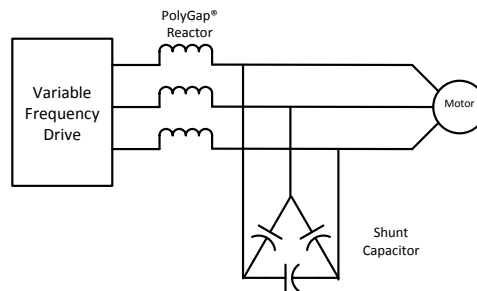

#### 3.2 L-C-L Filters for Active Front Ends (Grid Tied Inverters/ Inverter Based Resources)

Mangoldt's standard PolyGap® L-C-L Filters are Inductor-Capacitor-Inductor (L-C-L) type low pass filters which may be used in grid tied inverter applications. At the input side of a grid tied inverter, the PolyGap reactor impedes the flow of switching frequency (and its harmonics) current and together with the shunt capacitors forms a low pass filter that diverts these high frequencies away from the power source. The grid side reactor helps to divert high frequencies into the shunt capacitor and also helps to protect the capacitor from harmonics due to upstream loads.

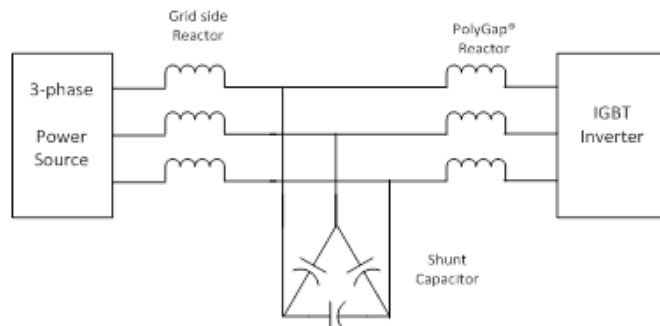

	<p style="text-align: center;">INSTALLATION, OPERATION AND MAINTENANCE MANUAL FOR LOW VOLTAGE PolyGap® Sinewave Filters</p>	<p style="text-align: center;">PSF-INSTR_006/210914 Rev_22-0909 Rev 23-0327</p>
--	-----------------------------------------------------------------------------------------------------------------------------------------	-----------------------------------------------------------------------------------------

### 3.3 20 year design life expectancy on reactors and capacitors with continuous operation

Mangoldt PolyGap® Sinewave Filters (Type PSF) are manufactured with high quality reactors and capacitors that are specifically designed for power electronic applications where a DC bus is switched via pulse width modulation (PWM). Mangoldt Type PSF Filters may be installed in electrical enclosures where the internal air surrounding these components is maintained at 45°C or lower. In cases where the reactors and capacitors may be mounted in separate enclosures, then the maximum surrounding air temperatures are as follows: reactors: 50C; capacitors: 45C.

Reactors are specially constructed using an exclusive technique called PolyGap® cores. This method uses numerous tiny air gaps in order to achieve superior saturation characteristics while minimizing harmonic losses and stray magnetic fields. Reactors have all been factory qualified under real life harmonic current conditions and UL testing was performed with the full harmonic current spectrum. Reactors are constructed with balanced inductance (all 3 phases) with +/- 3% tolerance for optimized filtering. Balanced inductance helps to maintain balanced current flow in the three phases and minimize the possibility of non-characteristic harmonics.

Mangoldt's PolyGap® reactors offer valuable advantages for sine wave filter applications because they minimize stray magnetic fields due to the switching frequency (and multiples of  $f_{sw}$ ) and prevent high frequency circulating currents in the windings. The result is lower power losses and less internal heat generation.

It is the customer's responsibility to install the filter in a suitable and well ventilated enclosure. Mangoldt PolyGap® Sinewave Filters are designed for natural convection cooling, in a well ventilated enclosure. Fans may be required if the enclosure and ambient conditions do not allow adequate heat removal. Refer to the Technical Data section (Section 9.0; pages 29-30) for filter watts losses.

#### Quality:

Mangoldt PolyGap® Sinewave Filters are designed and produced under quality standard ISO 9001 and are cULus Listed (Underwriter's Laboratories). All Mangoldt Sinewave filters are suitable for field repair using original equipment replacement parts.

### 3.3 Agency Approvals

Mangoldt Type PSF Sinewave Filters are UL Listed for both USA and Canada. (File E173113).

#### Configuration Codes:

Sinewave Filter: AC

**4.0 Catalog Numbering System**

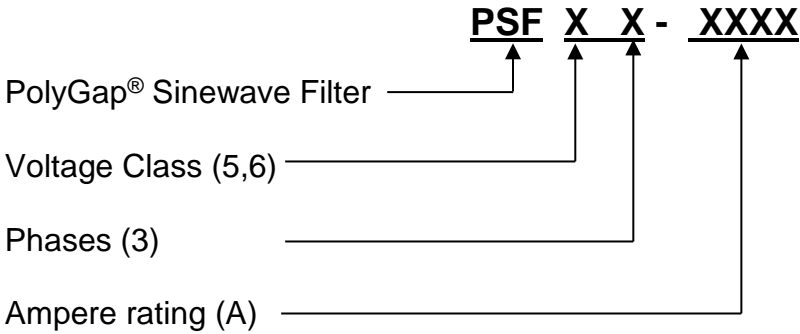

**Example: Catalog Number**

250HP, 302FLA, 480V, Sinewave Filter: **PSF53-0302**

50HP, 65FLA, 480V, Sinewave Filter Kit: **PSF53-0065**

Note: The customer is responsible for selecting the proper filter for their specific application and for installing, connecting, using and maintaining the filter in an appropriate manner and within its specifications. Feel free to contact the factory technical support office for guidance in selection of filters or for Application Engineering Support.

**4.1 Filters available as factory assembly or in KIT form**

Sinewave filters are offered as factory assembled units or as kits for customer assembly and wiring. Since the filters consist of both a reactor (Type PSD) plus multiple capacitors (Type LKT-F), in some cases the geometry may not fit the available space. In these cases, the kit form of the product may be more convenient.



Factory assembled filter

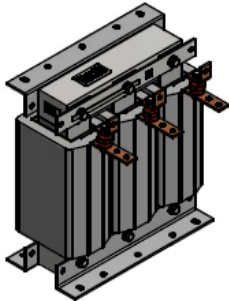

Filter Kit (Type PSD reactor + Type LKT-F capacitors)

Note: Type PSD reactors include provision for making capacitor connections at the reactor terminals.

## 4.2 Selection of Sine Wave Filters (480V) – Factory assembled

Sine wave filters are typically selected based upon motor voltage, frequency and full load amperes (FLA).

Cat. No.	Arms	HP	kW	mH	uF	Terminal	Watts Loss	Weight kg/lbs
PSF53-0005	5	3	2.2	14.5	1.5	Term. blk	45	6.4 / 14
PSF53-0008	8	5	3.7	9	2.2	Term. blk	70	7.6 / 17
PSF53-0011	11	7.5	5.6	6.5	3	Term. blk	90	10.8 / 24
PSF53-0015	15	10	7.5	4.8	4.7	Term. blk	110	12.7 / 28
PSF53-0021	21	15	11	3.4	6.8	Term. blk	140	15.8 / 35
PSF53-0027	27	20	15	2.7	6.8	Cu bar	170	23.8 / 52
PSF53-0035	35	25	19	2	10	Cu bar	180	24.4 / 54
PSF53-0040	40	30	22	1.8	10	Cu bar	220	28.9 / 64
PSF53-0052	52	40	30	1.38	15	Cu bar	260	30.9 / 68
PSF53-0065	65	50	37.3	1.1	20	Cu bar	310	41.5 / 91
PSF53-0077	77	60	45	0.93	20	Cu bar	350	40.4 / 89
PSF53-0100	100	75	56	0.72	33	Cu bar	410	58.7 / 129
PSF53-0125	125	100	75	0.57	33	Cu bar	450	68.9 / 152
PSF53-0156	156	125	93	0.46	47	Cu bar	550	78.4 / 172
PSF53-0187	187	150	112	0.39	47	Cu bar	620	91.9 / 202
PSF53-0240	240	200	149	0.3	66	Cu bar	850	121 / 266
PSF53-0302	302	250	187	0.24	94	Cu bar	935	158 / 348
PSF53-0361	361	300	224	0.2	94	Cu bar	1050	175 / 385
PSF53-0420	420	350	261	0.17	94	Cu bar	1200	195 / 429
PSF53-0480	480	400	298	0.15	141	Cu bar	1350	216 / 475
PSF53-0520	520	450	336	0.138	141	Cu bar	1400	244 / 537
PSF53-0590	590	500	373	0.12	141	Cu bar	1500	259 / 570
PSF53-0720	720	600	448	0.1	188	Cu bar	1750	302 / 664
PSF53-0840	840	700	522	0.085	188	Cu bar	1850	338 / 744
PSF53-1000	1000	850	634	0.07	282	Cu bar	2650	415 / 913
PSF53-1220	1220	1000	746	0.06	282	Cu bar	3100	469 / 1032
PSF53-1460	1460	1200	895	0.05	376	Cu bar	3500	565 / 1243

Note: Standard 480V sinewave filters may be applied at voltages of 380V to 480V and for VFD output frequencies up to 80Hz, without de-rating. For higher frequencies, PSF filters may be de-rated per the graph in section 4.3.

Note: Standard 480V sinewave filters may be applied at voltages of 380V to 480V in applications where the installation altitude is 1000 meters or less above sea level without de-rating. For higher altitudes, PSF filters may be de-rated per the chart in section 4.4.

### 4.3 De-rating for Sine wave filters operating above 80Hz.

Use this chart to derate sinewave filters for use between 80Hz and 150Hz. For higher frequencies, consult the factory technical sales support office.

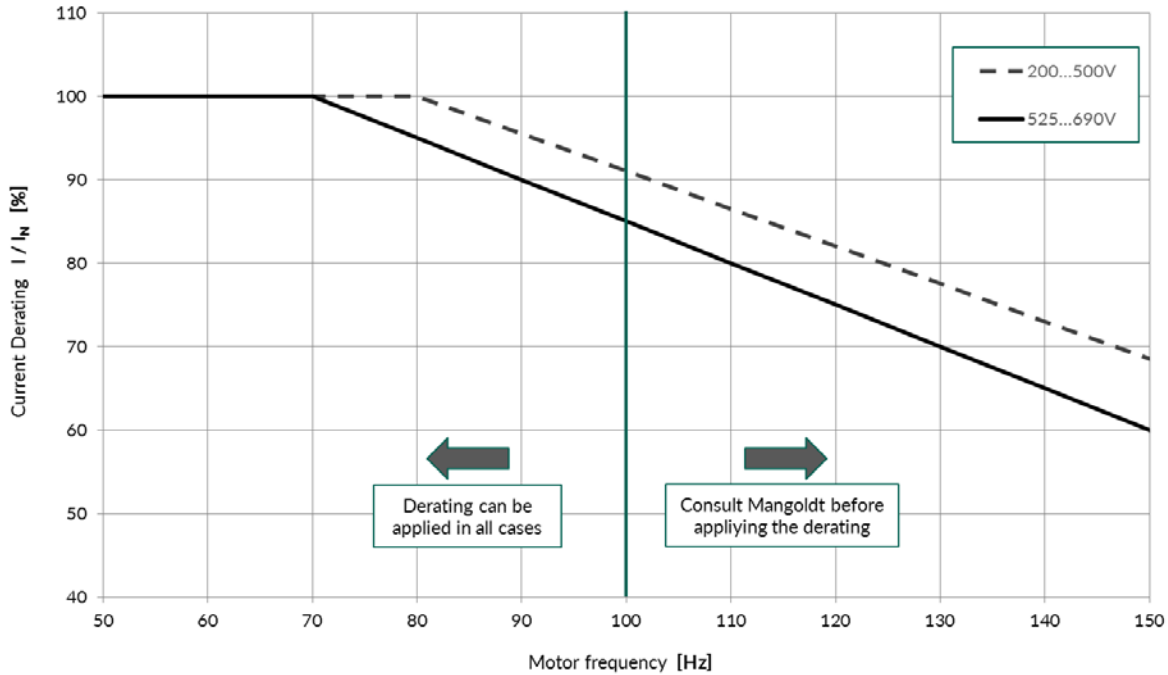

### 4.4 De-rating for Sine wave filters operating above 1000 meters above sea level.

Applications at altitudes above 1000 meters a.s.l require derating of both reactors and capacitors. Reactors are de-rated on the basis of current, while capacitors are de-rated on the basis of voltage. As standard, Mangoldt uses capacitors with voltage ratings about 25% greater than system voltage, enabling them to operate satisfactorily at altitudes up to about 3000 meters without de-rating. Reactors should be derated 0.3% for each additional 100 meters above 1000 meters. When FRAKO Type LKT-F capacitors are used, these capacitors are suitable for use at altitudes up to 4000 meters without de-rating.

<u>Altitude</u>	<u>Reactor Amps De-rate</u>	<u>Capacitor Voltage</u>
1000m	none	480V
1500m	98%	509V
2000m	97%	538V
2500m	95%	567V
3000m	93.5%	596V
3500m	92%	625V
4000m	90%	654V

The capacitor voltage derating information applies to those capacitors which are rated for use at up to 1000 meters above sea level. Derating is not required for FRAKO Type LKT-F capacitors for applications where the installation altitude does not exceed 4000 meters.

#### 4.5a Component Requirements for Sine Wave Filter KITS (480V; $f_c \geq 2\text{kHz}$ )

Motor Ratings		Mangoldt Reactor		FRAKO Capacitor	
HP	Amax	Qty	Catalog No.	Qty	Catalog No.
3	5	1	PSD53-0005	3	LKT-F-001.5-1-1200-BA
5	8	1	PSD53-0008	3	LKT-F-002.2-1-1200-BA
7.5	11	1	PSD53-0011	3	LKT-F-003.0-1-1200-BA
10	15	1	PSD53-0015	3	LKT-F-004.5-1-1200-BA
15	21	1	PSD53-0021	3	LKT-F-006.8-1-1200-BA
20	27	1	PSD53-0027	3	LKT-F-006.8-1-1200-BA
25	35	1	PSD53-0035	3	LKT-F-010.0-1-1200-BB
30	40	1	PSD53-0040	3	LKT-F-010.0-1-1200-BB
40	52	1	PSD53-0052	3	LKT-F-015.0-1-1200-BB
50	65	1	PSD53-0065	3	LKT-F-020.0-1-1200-BH
60	77	1	PSD53-0077	3	LKT-F-020.0-1-1200-BH
75	100	1	PSD53-0100	3	LKT-F-035.0-1-1200-BH
100	125	1	PSD53-0125	3	LKT-F-035.0-1-1200-BH
125	156	1	PSD53-0156	3	LKT-F-045.0-1-1200-BI
150	187	1	PSD53-0187	3	LKT-F-045.0-1-1200-BI
200	240	1	PSD53-0240	3 3	LKT-F-020.0-1-1200-BH LKT-F-045.0-1-1200-BI
250	302	1	PSD53-0302	3 3	LKT-F-045.0-1-1200-BI LKT-F-050.0-1-1200-BI
300	361	1	PSD53-0361	3 3	LKT-F-045.0-1-1200-BI LKT-F-050.0-1-1200-BI
350	420	1	PSD53-0420	3 3	LKT-F-045.0-1-1200-BI LKT-F-050.0-1-1200-BI
400	480	1	PSD53-0480	6 3	LKT-F-045.0-1-1200-BI LKT-F-050.0-1-1200-BI
450	520	1	PSD53-0520	6 3	LKT-F-045.0-1-1200-BI LKT-F-050.0-1-1200-BI
500	590	1	PSD53-0590	6 3	LKT-F-045.0-1-1200-BI LKT-F-050.0-1-1200-BI
600	720	1	PSD53-0720	6 6	LKT-F-045.0-1-1200-BI LKT-F-050.0-1-1200-BI
700	840	1	PSD53-0840	6 6	LKT-F-045.0-1-1200-BI LKT-F-050.0-1-1200-BI
850	1000	1	PSD53-1000	3 12	LKT-F-045.0-1-1200-BI LKT-F-060.0-1-1200-BJ
1000	1220	1	PSD53-1220	3 12	LKT-F-045.0-1-1200-BI LKT-F-060.0-1-1200-BJ
1200	1460	1	PSD53-1460	3 3 15	LKT-F-025.0-1-1200-BH LKT-F-050.0-1-1200-BI LKT-F-060.0-1-1200-BJ

### 4.5b Sine Wave Filter Component Data – Kits (480V; $f_c \geq 2\text{kHz}$ )

HP	Reactor	Capacitance (uF) [ 3x Δ ]	FRAKO Type LKT-F-xx.x-1-1200-xx Capacitors												Capacitor Totals						
			1	2	2	3	3	5	7	7	10	15	20	25	35	45	50	60	3x uF (Δ)	Quantity	fr (Hz)
3	PSD53-0005	14.5																1.5	3	623	15
5	PSD53-0008	9																2.2	3	653	15
7.5	PSD53-0011	6.5																3	3	658	15
10	PSD53-0015	4.8																4.5	3	612	15
15	PSD53-0021	3.4																6.8	3	604	15
20	PSD53-0027	2.7																6.8	3	678	15
25	PSD53-0035	2																10	3	650	22
30	PSD53-0040	1.8																10	3	685	22
40	PSD53-0052	1.38																15	3	639	22
50	PSD53-0065	1.1																20	3	620	40
60	PSD53-0077	0.93																20	3	674	40
75	PSD53-0100	0.72																35	3	596	40
100	PSD53-0125	0.57																35	3	670	40
125	PSD53-0156	0.46																45	3	625	45
150	PSD53-0187	0.39																45	3	679	45
200	PSD53-0240	0.3																65	6	653	85
250	PSD53-0302	0.24																95	6	612	90
300	PSD53-0361	0.2																95	6	670	90
350	PSD53-0420	0.17																95	6	727	90
400	PSD53-0480	0.15																140	9	632	135
450	PSD53-0520	0.138																140	9	659	135
500	PSD53-0590	0.12																140	9	706	135
600	PSD53-0720	0.1																190	12	670	180
700	PSD53-0840	0.085																190	12	727	180
850	PSD53-1000	0.07																285	15	654	245
1000	PSD53-1220	0.06																285	15	706	245
1200	PSD53-1460	0.05																375	21	670	335

#### 4.6 Sine Wave Filter Component Data – Kits (480V; $f_c \geq 5\text{kHz}$ )

Sinewave filters may alternatively be configured in such a way to serve applications where the switching frequency is 5kHz or higher. This can be accomplished by using the same PSD reactor plus a smaller capacitor ( $\mu\text{F}$ ) rating. In the case of the 5A thru 11A filters (for 5kHz and higher), the capacitance value is too small for a delta connection and is therefore made with a wye connection.

##### 4.6a Sinewave Filters (for $f_{sw} \geq 5\text{kHz}$ ) Connection Diagrams:

For Sinewave Filters rated 5A, 8A and 11A where  $f_{sw} \geq 5\text{kHz}$ :

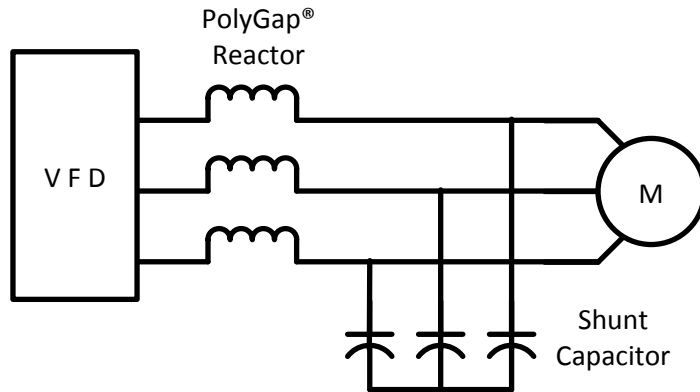

For Sinewave Filters filters rated 14A and higher where  $f_{sw} \geq 5\text{kHz}$ :

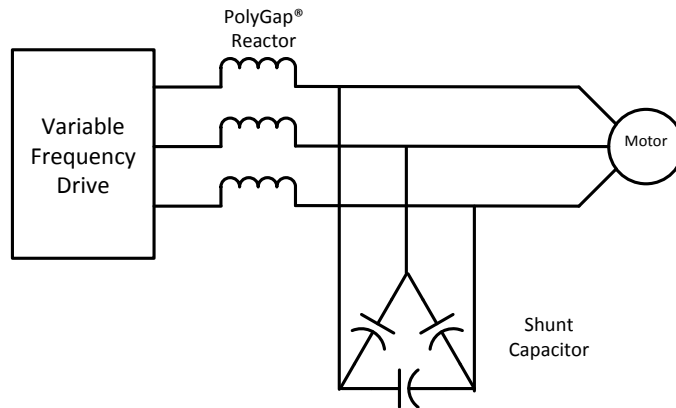

#### 4.6b Sine Wave Filter Component Data – Kits (480V; $f_c \geq 5\text{kHz}$ )

<b>480V PolyGap® Sine Wave Filter Kits (<math>f_{sw} \geq 5\text{kHz}</math>)</b>
-----------------------------------------------------------------------------------

Motor Ratings		Mangoldt		FRAKO	
		Reactor		Capacitor	
HP	Amps max	Qty	Catalog No.	Qty	Catalog No.
3	5	1	PSD53-0005	3	LKT-F-001.0-1-1200-BA
5	8	1	PSD53-0008	3	LKT-F-001.5-1-1200-BA
7.5	11	1	PSD53-0011	3	LKT-F-002.2-1-1200-BA
10	15	1	PSD53-0015	3	LKT-F-001.0-1-1200-BA
15	21	1	PSD53-0021	3	LKT-F-001.5-1-1200-BA
20	27	1	PSD53-0027	3	LKT-F-001.5-1-1200-BA
25	35	1	PSD53-0035	3	LKT-F-002.2-1-1200-BA
30	40	1	PSD53-0040	3	LKT-F-002.2-1-1200-BA
40	52	1	PSD53-0052	3	LKT-F-003.0-1-1200-BA
50	65	1	PSD53-0065	3	LKT-F-003.3-1-1200-BA
60	77	1	PSD53-0077	3	LKT-F-004.5-1-1200-BA
75	100	1	PSD53-0100	3	LKT-F-006.8-1-1200-BA
100	125	1	PSD53-0125	3	LKT-F-007.1-1-1200-BA
125	156	1	PSD53-0156	3	LKT-F-010.0-1-1200-BB
150	187	1	PSD53-0187	3	LKT-F-010.0-1-1200-BB
200	240	1	PSD53-0240	3	LKT-F-015.0-1-1200-BB
250	302	1	PSD53-0302	3	LKT-F-015.0-1-1200-BB
300	361	1	PSD53-0361	3	LKT-F-020.0-1-1200-BB
350	420	1	PSD53-0420	3	LKT-F-025.0-1-1200-BH
400	480	1	PSD53-0480	3	LKT-F-025.0-1-1200-BH
450	520	1	PSD53-0520	3	LKT-F-035.0-1-1200-BH
500	590	1	PSD53-0590	3	LKT-F-035.0-1-1200-BH
600	720	1	PSD53-0720	3	LKT-F-045.0-1-1200-BI
700	840	1	PSD53-0840	3	LKT-F-045.0-1-1200-BI
850	1000	1	PSD53-1000	3	LKT-F-060.0-1-1200-BJ
1000	1220	1	PSD53-1220	3	LKT-F-020.0-1-1200-BH
				3	LKT-F-045.0-1-1200-BI
1200	1460	1	PSD53-1460	3	LKT-F-035.0-1-1200-BH
				3	LKT-F-045.0-1-1200-BI

**Note: 5A thru 11A use wye connection of capacitors. All others use delta connection.**

### 4.6c Sine Wave Filter Component Data – Kits (480V; $f_c \geq 5\text{kHz}$ )

Filter Catalog Number	Reactor Catalog Number	Inductance (mH)	Capacitance (uF) [ $3\% \Delta$ ]	LKT-F-001.0-1-1200-BA	LKT-F-001.5-1-1200-BA	LKT-F-002.2-1-1200-BA	LKT-F-003.0-1-1200-BA	LKT-F-003.3-1-1200-BA	LKT-F-004.5-1-1200-BA	LKT-F-006.8-1-1200-BA	LKT-F-007.1-1-1200-BA	LKT-F-010.0-1-1200-BB	LKT-F-015.0-1-1200-BB	LKT-F-020.0-1-1200-BH	LKT-F-025.0-1-1200-BH	LKT-F-035.0-1-1200-BH	LKT-F-045.0-1-1200-BI	LKT-F-050.0-1-1200-BI	LKT-F-060.0-1-1200-BJ	Total Capacitance (uF)	Total Capacitors (3-phases total)	Capacitor Amax	$f_r$ (Hz)
WYE	PSF53-0005	14.5	0.95	3	3														1	3	15	1356	
	PSF53-0008	9	1.39	3															1.5	3	15	1422	
	PSF53-0011	6.5	1.90	3															2.2	3	15	1433	
Delta	PSF53-0015	4.8	1.10	3															1	3	15	1326	
Delta	PSF53-0021	3.4	1.59	3	3														1.5	3	15	1249	
Delta	PSF53-0027	2.7	1.59	3	3														1.5	3	15	1401	
Delta	PSF53-0035	2	2.34	3		3													2.2	3	15	1343	
Delta	PSF53-0040	1.8	2.34	3	3														2.2	3	15	1415	
Delta	PSF53-0052	1.38	3.51	3		3													3	3	15	1320	
Delta	PSF53-0065	1.1	4.68	3			3												3.3	3	15	1280	
Delta	PSF53-0077	0.93	4.68	3				3											4.5	3	15	1392	
Delta	PSF53-0100	0.72	7.73	3				3											6.8	3	15	1232	
Delta	PSF53-0125	0.57	7.73	3						3									7.1	3	15	1384	
Delta	PSF53-0156	0.46	11.01	3							3								10	3	22	1291	
Delta	PSF53-0187	0.39	11.01	3							3								10	3	22	1402	
Delta	PSF53-0240	0.3	15.46	3								3							15	3	22	1349	
Delta	PSF53-0302	0.24	22.01	3							3								15	3	22	1264	
Delta	PSF53-0361	0.2	22.01	3								3							20	3	40	1385	
Delta	PSF53-0420	0.17	22.01	3									3						25	3	40	1502	
Delta	PSF53-0480	0.15	33.02	3									3						25	3	40	1306	
Delta	PSF53-0520	0.138	33.02	3										3					35	3	40	1361	
Delta	PSF53-0590	0.12	33.02	3										3					35	3	40	1460	
Delta	PSF53-0720	0.1	44.03	3													3		45	3	45	1385	
Delta	PSF53-0840	0.085	44.03	3													3		45	3	45	1502	
Delta	PSF53-1000	0.07	66.04	3														3	60	3	50	1351	
Delta	PSF53-1220	0.06	66.04	3										3					65	6	85	1460	
Delta	PSF53-1460	0.05	88.06	3															80	6	85	1385	

Note: 5A thru 11A use wye connection of capacitors. All others use delta connection.

	<p style="text-align: center;">INSTALLATION, OPERATION AND MAINTENANCE MANUAL FOR LOW VOLTAGE PolyGap® Sinewave Filters</p>	<p style="text-align: right;">PSF-INSTR_006/210914 Rev_22-0909 Rev 23-0327</p>
--	-----------------------------------------------------------------------------------------------------------------------------------------	----------------------------------------------------------------------------------------

## 5.0 Transportation, Handling and Storage

**CAUTION: Improper handling may cause product damage or injuries and may result in the invalidation of the warranty!**

### 5.1 Filter Transportation

Mangoldt Sinewave Filter components are shipped in either corrugated cartons or wooden crates, depending on ratings, to offer maximum protection during shipment. The permitted transportation temperature range is -40°C to +80°C. Also, observe the notes regarding storage and transport on the product packages.

### 5.2 Filter Handling

All filters/reactors above 50 kg (110 lbs) product weight are equipped with lifting bars on the reactor for lifting of the product. These lifting bars are equipped with holes or cut-outs for transport hooks. These holes or cut-outs should be used for lifting the products from pallets or out of crates and to mount them in the installation. For products with less weight transport magnets can be easily utilized.

**CAUTION:** The reactors must never be lifted by the terminals nor the windings. These are not designed to carry the weight of the products. Before moving or lifting the product, ensure that your selected lifting equipment and lifting method complies with the product weight.

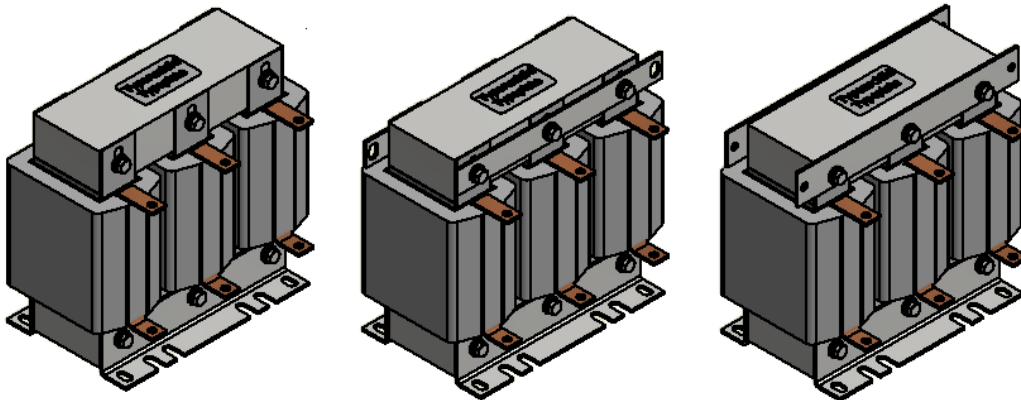

**EXAMPLE: REACTOR WITHOUT LIFTING BARS (LEFT), REACTOR WITH LIFTING BARS WITH DIAGONAL LIFTING HOLES AND REACTOR WITH LIFTING BARS WITH LIFTING HOLES ON BOTH SIDES**

### 5.3 Filter Storage

Permitted storage temperature range: 0°C to +45°C.  
 Also observe the notes on cartons/crates regarding storage and transport.  
 Protect the products from moisture and corrosion.  
 Avoid mechanical stressing, throwing, tipping or dropping of the products.  
 Only use lifting equipment suitable for the weight of the product.  
 Use suitable protective equipment and wear protective clothing during transport.  
 Do not stand under hanging loads.

	INSTALLATION, OPERATION AND MAINTENANCE MANUAL FOR LOW VOLTAGE PolyGap® Sinewave Filters	PSF-INSTR_006/210914 Rev_22-0909 Rev 23-0327
--	---------------------------------------------------------------------------------------------------	----------------------------------------------------

## 6.0 Installation

**CAUTION: Risk of injuries due to live parts! Risk of injuries due to hot surfaces! Risk of injuries due to lifting of heavy loads!**

Mangoldt Type PSF Sinewave Filters must be installed according to local electrical codes and regulations in an enclosure providing adequate ventilation or adequate forced air cooling. The filter installation must assure that the reactors and capacitors are all installed in a manner such that surrounding air temperatures do not exceed 45°C during operation of the filter at rated load conditions. They should be assembled and wired only by trained and qualified electrical personal. Install the products only when they are de-energized and not connected electrically. Use suitable lifting equipment and protective equipment and wear protective clothing during transportation.

Please note the safety information from the preceding chapters, and in particular the notes on transport of products in section 5.0. Carry out all work with extreme caution to minimize the risk of accidents and damage.

### 6.1 Preparing for Installation

Upon arrival, the packing list and shipment should be carefully checked for completeness. The crating must be examined for transportation damage. In the event of visible transportation damage, please file your claim immediately with the shipment carrier. Note: Mangoldt does not accept responsibility for damage caused during transportation.

Prepare product for assembly as follows:

- a) Check all components for visible damage. Defective components may not be mounted or used.
- b) Ensure that dimensions and tolerances for the area or equipment in which the filter is to be installed are suitable for product attachment.
- c) Ensure that mounting can be done in a clean, dry and dust-free environment.
- d) Have all necessary tools and auxiliary material, as well as measuring and testing equipment readily available.
- e) Check whether all components, assembly surfaces and threads are clean.
- f) Remove the transportation screws and remove products from their packaging (carton or crate).

Note: In the event that the equipment is not installed immediately after arrival, it should be placed in intermediate storage without removing the packing. In this case, the crates are to be stored on a level area of sufficient strength to bear their weight and in a clean and non-corrosive atmosphere. If the intermediate storage is outdoors, the period of storage must be limited to approximately 6 months, depending on the atmospheric conditions.

## 6.2 Mechanical Mounting

Each filter offers multiple mounting holes for customer convenience. Always secure each reactor to a metal panel using four machine screws (bolts), lock washers and nuts. To attach reactors correctly and safely to the panel, Mangoldt recommends the bolts, nuts and washers as indicated in the table below. Stainless steel hardware material V2a (standard A2, A4, A2-70, A4-70) is recommended for both screws and washers which reduces the danger of overheating of these parts due to induced voltages caused by the stray fields of the products.

Filters should be mounted securely in such a manner that will not induce additional heating of the capacitors from other sources. The preferred method is to locate capacitors vertically beneath the reactors. Reactors may be mounted on either a horizontal or vertical panel, however, the best heat dissipation and coil temperature control will be achieved when filters are mounted in such a way so the axis of the reactor coils is in the vertical plane and coils are to the left or right of each other. This allows air to naturally flow by convection between the coils as well as across the core.

### BOLTS, NUTS AND WASHERS FOR MECHANICAL MOUNTING

Hole(mm)	Bolt	Nut	Washer	Torque (Nm)
Ø6	M5 - DIN EN ISO 4014	M5 - DIN EN ISO 8673	M5 - DIN EN ISO 125	3,5
Ø7	M6 - DIN EN ISO 4014	M6 - DIN EN ISO 8673	M6 - DIN EN ISO 125	6
Ø9	M8 - DIN EN ISO 4014	M8 - DIN EN ISO 8673	M8- DIN EN ISO 125	16
Ø11	M10 - DIN EN ISO 4014	M10 - DIN EN ISO 8673	M10- DIN EN ISO 125	32
Ø13	M12 - DIN EN ISO 4014	M12 - DIN EN ISO 8673	M12- DIN EN ISO 125	56

**Note:** If other screws and washers than those listed in this recommendation are used, the property class of the screws and the hardness class of the washers must be equivalent to allow for application of the required tightening torque.

Mangoldt Sinewave Filters are designed for floor mounting:

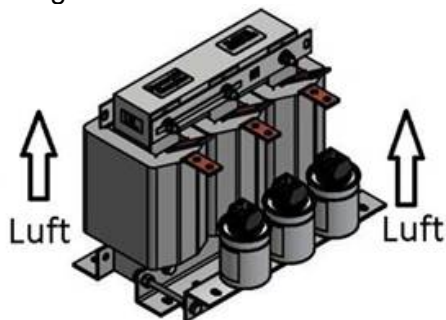

<b>STANDARD FLOOR MOUNTING FOOT BRACKETS AND ITS AIR FLOW (Luft) DIRECTION FOR NATURAL CONVECTION COOLING.</b>
------------------------------------------------------------------------------------------------------------------------

Once the filters have all been mechanically installed, verify the torques of all the bolts/nuts used for mechanical mountings.

After having satisfactorily mounted the filters mechanically as prescribed above, confirm that cooling/ventilation is adequate.

### 6.3 Electrical Connections

All field connections are made to the reactor terminals. There are two basic styles of reactor terminations: 1) with copper tab terminals; 2) with box type terminal blocks. Each filter includes a grounding (earthing) terminal which must be connected to the system ground. The grounding terminal is identified on each reactor with either the standard ground symbol or by a “PE” label. Always connect the ground conductor to the reactor grounding terminal before proceeding with the power circuit wiring.



Reactor with bus bar terminals

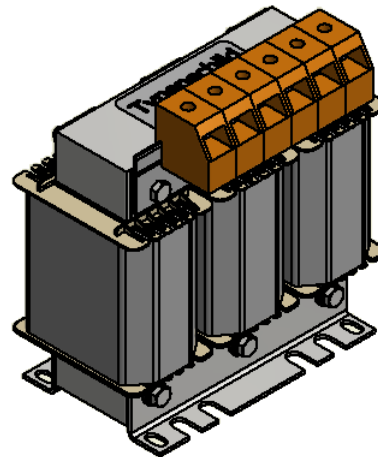

Reactor with terminal blocks

#### Filter Ground (earthing) terminations

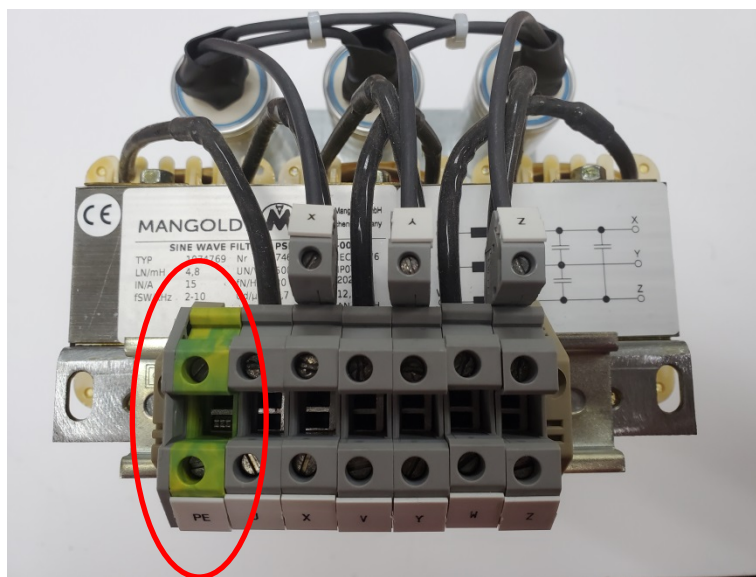

	INSTALLATION, OPERATION AND MAINTENANCE MANUAL FOR LOW VOLTAGE PolyGap® Sinewave Filters	PSF-INSTR_006/210914 Rev_22-0909 Rev 23-0327
--	---------------------------------------------------------------------------------------------------	----------------------------------------------------

## 6.4 Filter wiring procedures:

**DANGER: High voltage and high working current!**

**Risk of death or severe bodily injury by electric shock!**

Only those personnel trained and qualified to work with or on electrical equipment are permitted to install, operate, maintain or repair this equipment.

Follow general construction and safety regulations when working on electrical power installations.

Install filters in accordance with local electrical codes/regulations including NFPA 70 National Electrical Code (USA) and C22 Canadian Electrical Code (Canada).

Before energizing any electrical equipment or components, verify the equipment grounding conductor is permanently connected to all electrical components and equipment in accordance with the connection diagram and local electrical safety regulations.

Do not operate electrical equipment at any time, even for brief measurements or tests, if the equipment grounding conductor is not permanently connected to the mounting points of the components provided for this purpose.

Never touch the electrical connection points of a component while power is turned on.

Before energizing the equipment, cover and safeguard all live parts safely to prevent contact with those parts.

Protect all components against direct contact with live parts.

The operator must observe all the above regulations at all times.

Complete the electrical connection of the products according to the information in section 6.3.

- Always connect ground conductor first.
- Connect the supply cables or supply bus bars to the terminals. Refer to Section 6.3a for reactors with copper bus bar terminals and to Section 6.3b for reactors with terminal blocks.
- Use the bolting parts suggested by Mangoldt in Section 6.3. If you utilize parts other than those suggested, be certain to use identical dimensions and identical mechanical strength in order to keep the electrical spacing intact and to allow for proper torque.
- Check that there is no mechanical stress on the terminals.
- Check that there is no mechanical stress on cables or bus bars of the installation.
- Check the fit and accuracy of the connection before you proceed.
- Use two wrenches (above and below terminal) when securing terminal screws.
- Log all measurements (torque, electrical spacing after terminals are attached, etc.) in the commissioning log.

### 6.4.1 Electrical Connections for Reactors with Copper Bus Bar terminals

These terminals are made of solid copper bars (according to standard DIN 46206) regardless of the winding material (copper or aluminum). The cable lug or busbar should be positioned on the top of the reactor terminal. The bolt head should be positioned on the top side of the terminal (nut on the bottom side). The connection consists of bolt (head), washer, system terminal, reactor busbar terminal (copper bar), washer, spring (locking) washer and nut. The length of the bolt should be as short as possible. A maximum excess length of 15 mm is recommended.

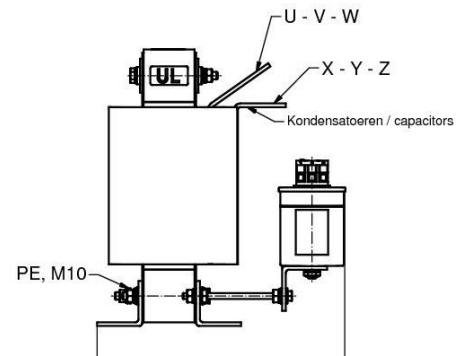
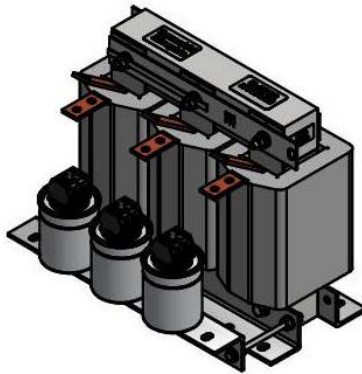
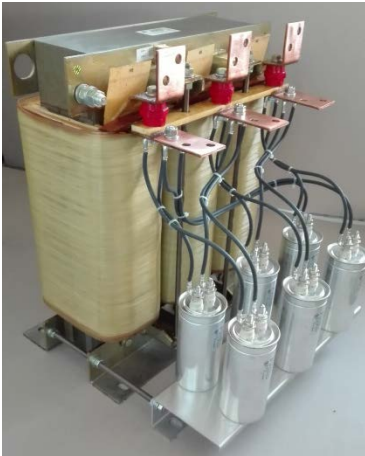

**MANGOLDT RECOMMENDS THE USE OF BOLTS, NUTS AND WASHERS LISTED IN THE TABLE BELOW FOR THE ELECTRICAL CONNECTIONS FOR FILTERS HAVING REACTORS WITH COPPER BAR TERMINALS.**

∅ connection (mm)	Copper bar area (mm <sup>2</sup> )	Bolt DIN4014	Washer DIN125	Nut DIN8673	Spring washer DIN127	Torque (Nm)
9	20 x 3	M8 FK8.8, max. excess length 15 mm	M8	M8	M8	25
11	30 x 3/4/5	M10 FK8.8, max. excess length 15 mm	M10	M10	M10	49
14	bigger than 40 x 3	M12 FK8.8, max. excess length 15 mm	M12	M12	M12	86

BOLTS, WASHERS, NUTS, SPRING WASHERS AND TORQUE VALUES FOR CONNECTION WITH COPPER BUS BARS

**Note:** For filters with copper tab type terminals, wiring connection must be made using a bolted connection as shown on the following page. Use two wrenches (one on the bolt head and one on the nut) to tighten the termination. Failure to use this method may cause irreversible damage to the reactor.

**Note:** For filters with copper tab type terminals, wiring connection must be made using a bolted connection. Use two wrenches (one on the bolt head and one on the nut) to tighten the termination. Failure to use this method may cause irreversible damage to the reactor.

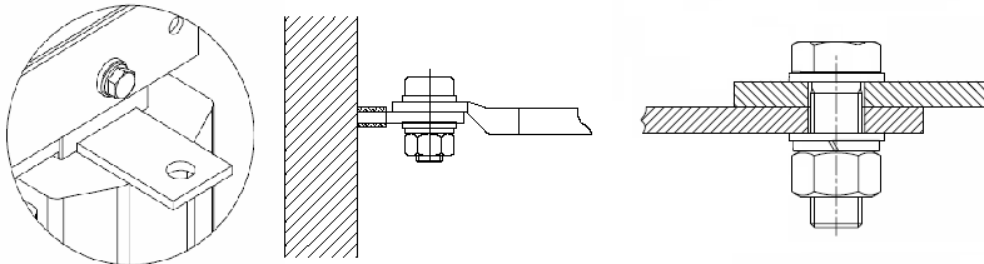

**EXAMPLE: DRAWING OF BOLT IN ELECTRICAL CONNECTION WITH COPPER BUS BARS**

#### 6.4.2 Electrical Connection for Filters and Reactors with Terminal Blocks

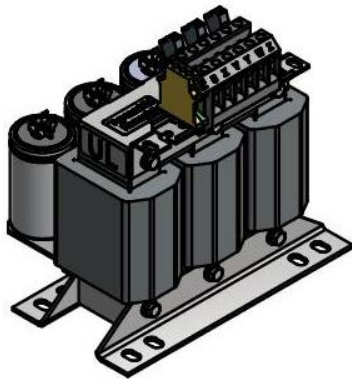

**EXAMPLE: FILTERS WITH TERMINAL BLOCKS**

**Mangoldt strongly suggests the maximum diameters and torques listed below for the electrical connection on all phases of reactors with terminal blocks.**

Terminal	Wire size (awg)	Maximum current	Bolt Size	Torque (US)
M4/6	22 to 10	30 A	M3	4.4 - 7.4 Lb in
UT16	16 to 4	85 A	M5	20 Lb in

	INSTALLATION, OPERATION AND MAINTENANCE MANUAL FOR LOW VOLTAGE PolyGap® Sinewave Filters	August 27, 2021
--	---------------------------------------------------------------------------------------------------	-----------------

## 6.5 Cooling / Ventilation Considerations

Filters are considered as significant sources of heat and their operation will increase the internal air inside of the electrical enclosure in which they are installed. Be sure to consider the increased air temperature within the enclosure and ensure that it does not exceed the maximum permissible air temperature for each of the filters of 45°C.

Capacitors are the most sensitive to heat and should be located in a well ventilated area within the enclosure (preferably beneath heat sources). Refer to Watts data in Section 9 (pages 29-30).

## 6.6 Natural Convection Cooling / Ventilation

When cooling with natural convection, the optimum cooling of the product will be achieved with a vertical direction of the winding axis. Furthermore insure that the cooling air can flow unhindered and can also dissipate heat generated by the filter components. For reactors, a minimum distance of 12mm with regards to other components of the installation or the walls of the housing is required. For capacitors, a minimum distance of 20mm with regards to other components of the installation or the walls of the housing is required. Additionally, a minimum distance of 30mm is required above the capacitor so that the over-pressure device can function properly in the event of internal over-pressure. If a minimum distance due to electrical spacing is required by global or local standards, the system designer must make sure that these distances are considered in the installation.

Dimension your installation so that the cooling air temperature does not exceed the maximum ambient (surrounding air) temperature specified for each component.

- Mount filters with the reactor winding axis vertical if natural convection is used for the product cooling.
- Consider the minimum distance between components of your installation with respect to air flow and electrical distances.
- Make sure that the temperature of the cooling air does not overstep the maximum surrounding air temperature specified for the product.

## 6.7 Forced Air (Fan) Cooling

When forced ventilation is applied, the winding axis may deviate from vertical. In this case the cooling air must flow in the direction of the winding axis. The winding will be cooled in an optimal way, if the forced ventilated air flows around and through the winding in the direction of the winding axis. Optimal cooling of the filters can only be assured, if the air flow is parallel to the winding axis.

## 6.8 Prior to Electrical Energization

**DANGER: High voltage and high working current!**

**Risk of death or severe bodily injury by electric shock!**

After the electrical connection is completed and verified you may proceed to commission the products.

Check the electrical load of the filter during normal operation at rated load conditions and verify currents in each filter component are within the limits stated on the product nameplates. If possible check these during operation at the maximum load condition.

Check the thermal load of the filter components and verify it is within the rated limits for each component.

Operate the equipment at full rated load conditions for a period of time long enough for the internal air temperature to stabilize. Check the enclosure internal air temperature surrounding each of the components and verify it is within the specified limit.

Log all measured data in the commissioning log.

Make sure that all of the components are properly connected to ground using the grounding terminals provided.

## 6.9 Power Terminal Markings:

Reactors: Power terminals are marked as follows:

Input terminals: U, V, W

Output terminals: X, Y, Z (capacitors are connected to these terminals)

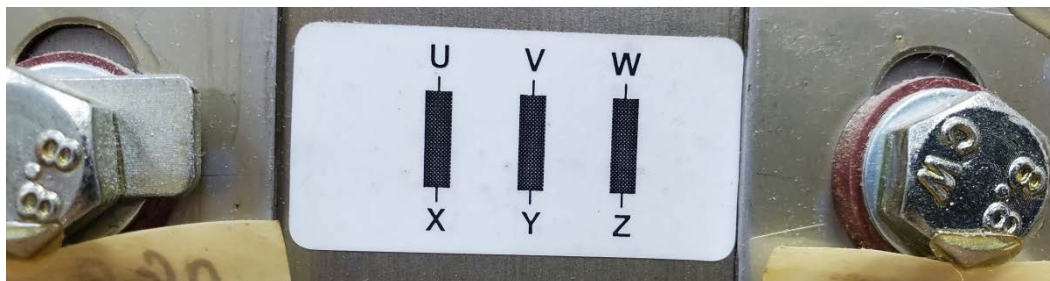

Capacitors: terminals are not marked. There is no polarity associated with the capacitors.

## 7.0 PolyGap® Sinewave Filter and L-C-L Filter Applications

Mangoldt PolyGap® Sinewave Filters are multi-purpose and may be used on either the input side of a grid tied inverter or on the output side of a VFD depending on your needs. Some applications such as VFDs with active front ends may use both filters.

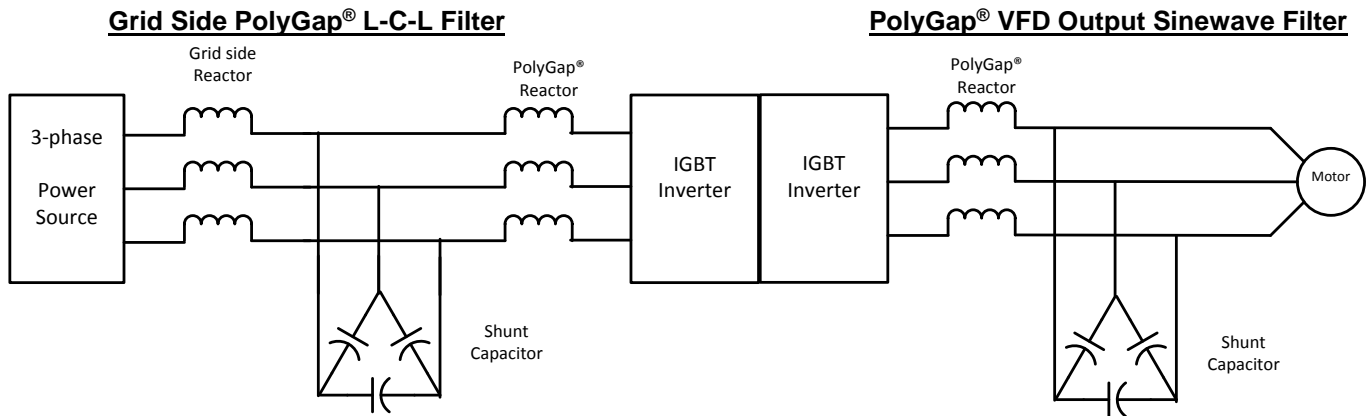

## 7.1 PolyGap® VFD Output Sinewave Filter

The purpose of this filter is to convert the VFD output pulsed (PWM) voltage pattern to a near sinewave. Motors generally run cooler and quieter when supplied from sinewave voltage rather than PWM voltage. Additionally, when motor cables are long, PWM voltage can experience pulse reflections at the motor end which increase (potentially doubling) the peak voltage at the motor terminals and cause a high dv/dt rate. Excessive peak terminal voltage can lead to catastrophic motor winding failures (typically in the first turns). High dv/dt can lead to accelerated ageing of the dielectric system and eventual internal winding failures. For best results, connect this filter as close as possible to the VFD output terminals.

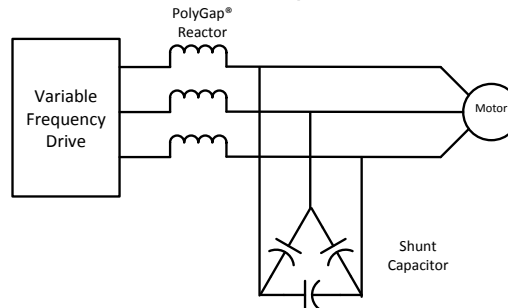

Mangoldt PolyGap® Sinewave Filters are low pass filters that can significantly reduce the switching frequency current and voltage in applications where VFDs supply PWM voltage to a motor. They can typically improve the quality of the VFD controlled motor voltage to about 5%THD-v or less.

Mangoldt PolyGap® Sinewave Filters are connected in series with the output terminals of a VFD for one or more motors which are within the maximum current rating of the filter.

The main objective of these filters is to convert the VFD output voltage from PWM to a near sinewave with minimal voltage distortion. This process enables the motor to run cooler, quieter and to experience a longer life.

## 7.2 L-C-L Filter for Active Front Ends

Mangoldt offers L-C-L Filters for use with inverters that have an Active (IGBT) Front End (inverter). These are commonly used in renewable energy applications such as photovoltaic converters and for AC drives with a low harmonic distortion active front end or active regenerative front end.

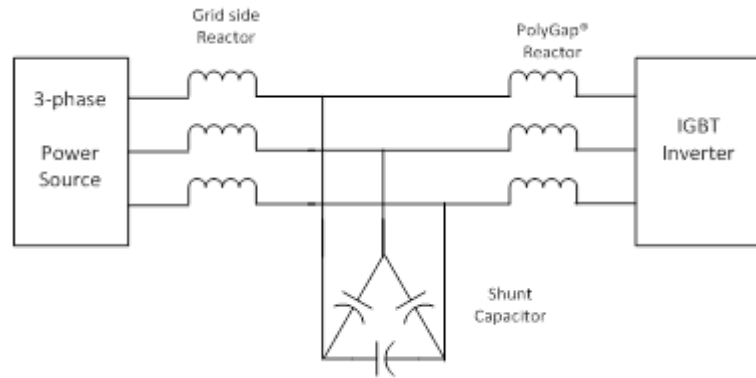

The Mangoldt L-C-L Filter consists of a PolyGap® Sinewave Filter with the reactor nearest to the inverter plus a “5-in-1” Line/Load Reactor on the grid side of the filter.

If needed, Mangoldt can produce this with an input transformer in lieu of the grid side reactor. In some cases, the customer transformer may serve as a substitute for the grid side reactor. Contact the Technical Support Office for either of these applications involving transformers.

## 7.3 Power Terminal Markings:

Reactors: Power terminals are marked as follows:

Input terminals: U, V, W

Output terminals: X, Y, Z

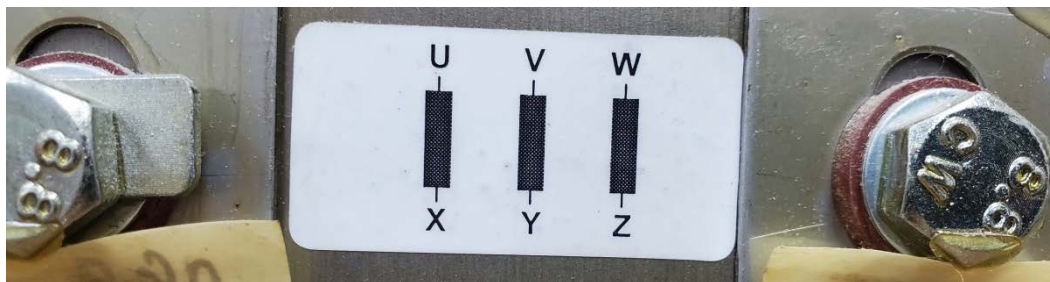

Capacitors: terminals are not marked. There is no polarity associated with the capacitors.

## 7.4 Connection Diagrams

### 7.4.1 Connection Diagram for VFD Output Side Applications

5kHz Filters rated 5A, 8A and 11A:

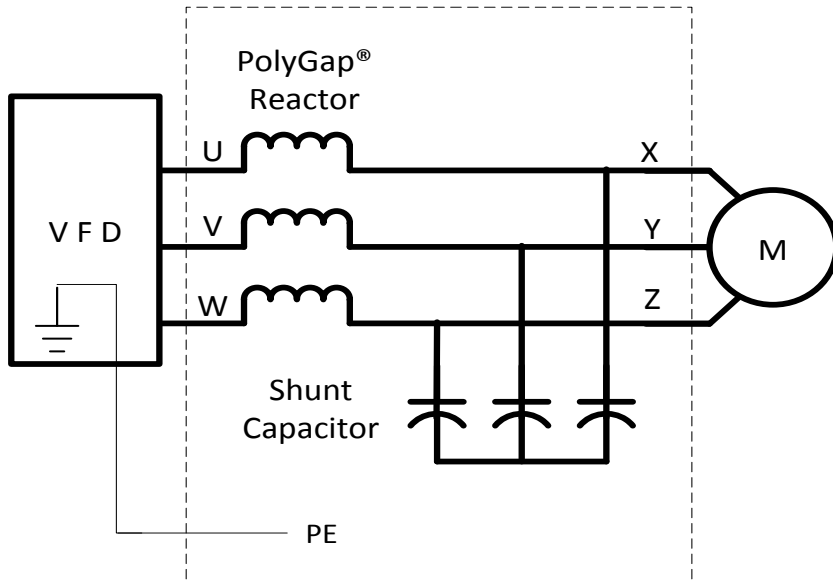

5kHz Filters rated 14A and higher:

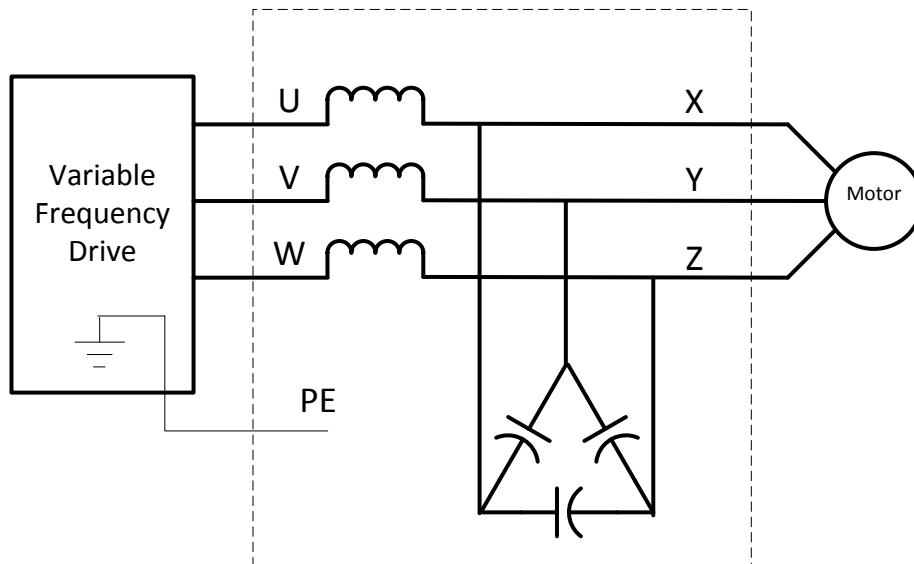

**Note: All wiring connections must be carried out in accordance with national and local electrical codes. Power circuit conductors must have minimum ampacity sufficient for rating of the filter and rating of the adjustable speed drive.**

### 7.4.2 Connection Diagram for VFD Output Side and Multiple Motor Applications

For applications where a single Sinewave Filter will supply multiple motors make sure the sinewave filter maximum current rating equals or exceeds the sum of all motor full load ampere (FLA) ratings.

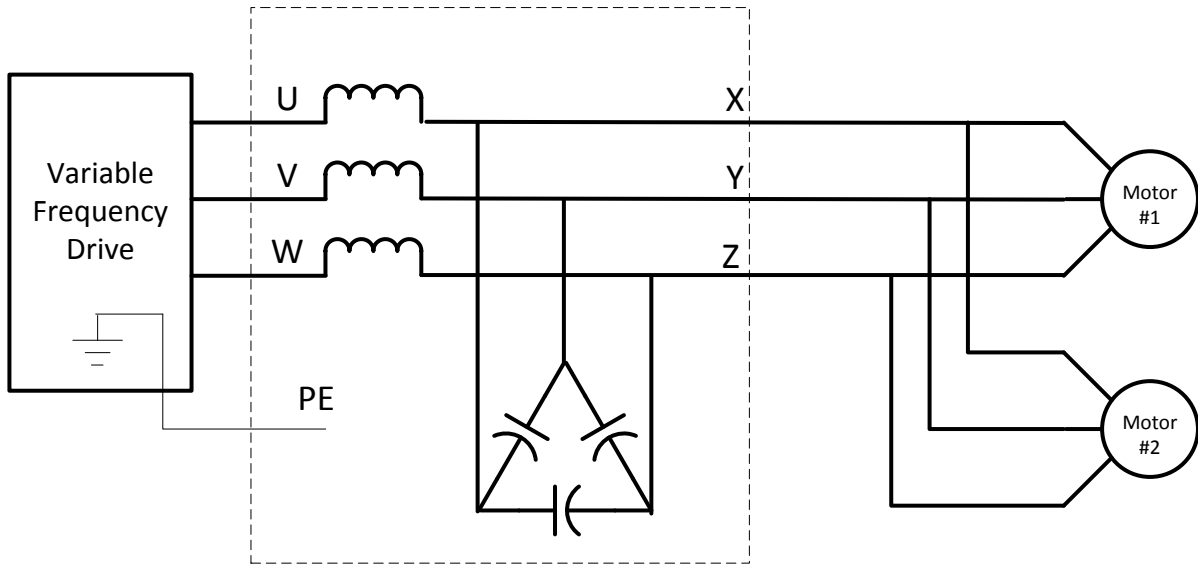

**Example: One sinewave filter serving two (2) 10HP motors (each is 14 FLA)**

$$2 \times 14A = 28 \text{ FLA}$$

Select PSF53-0035 Sinewave filter

**Example: One sinewave filter serving three (3) 5HP motors (each is 7.6FLA)**

$$5 \times 7.6A = 38 \text{ FLA}$$

Select PSF53-0040 Sinewave filter

**Example: One sinewave filter serving three motors rated (1) 5HP, (1) 7.5HP, (1) 10HP**

$$5\text{HP} = 7.6\text{FLA}, 7.5\text{HP} = 11\text{FLA}, 10\text{HP} = 14\text{FLA}$$

$$7.6A + 11A + 14A = 32.6\text{FLA}$$

Select PSF56-0035

**Note: All wiring connections must be carried out in accordance with national and local electrical codes. Power circuit conductors must have minimum ampacity sufficient for rating of the filter and rating of the adjustable speed drive.**

## 8.0 Technical Data and Filter Performance

### 8.1 Specifications for use at VFD output

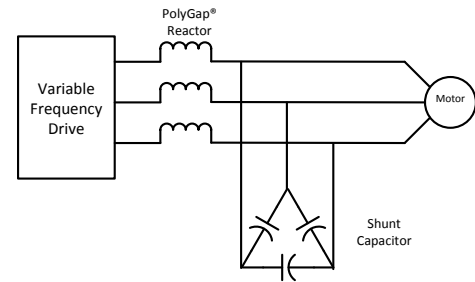

System Voltage:	480V; F <sub>sw</sub> ≥2kHz	480V; F <sub>sw</sub> ≥5kHz
VFD Output Frequency:	Up to 80hz without derating; Above 80Hz: use derating curve (8.1a)	Up to 60hz without derating
PWM Switching Frequency (f <sub>sw</sub> ):	2kHz or higher	5kHz or higher
Voltage Distortion:	Typically 3% to 5% THD-v; improves as f <sub>sw</sub> increases	Typically 5-8% THD-v; improves as f <sub>sw</sub> increases
Service Factor:	1.0 x maximum ampere rating	1.0 x maximum ampere rating
Power losses:	≤1% typical	≤1% typical
Altitude:	1000 meters maximum	1000 meters maximum
Relative Humidity:	95% maximum	95% maximum
dv/dt:	Reduced to less than 100V/usec	Reduced to less than 100V/usec

#### 8.1.a Derating Curve for output Frequency above 80Hz (2kHz filters only)

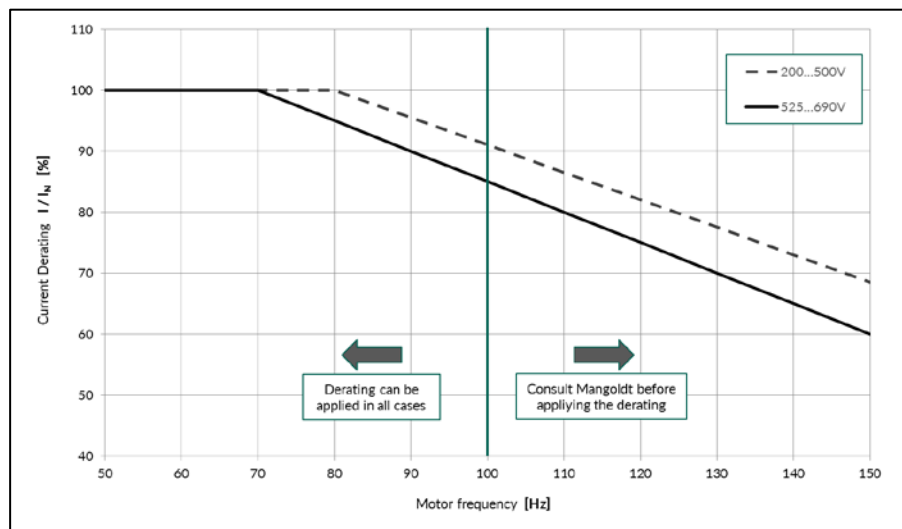

## 8.2 Typical Filter Performance (2kHz filters)

The distortion of the filter output waveform can vary based upon several factors, including: PWM switching frequency, motor operating speed (output frequency of VFD) and cable parameters.

Typical filter output waveform when VFD switching frequency is set to 2kHz:

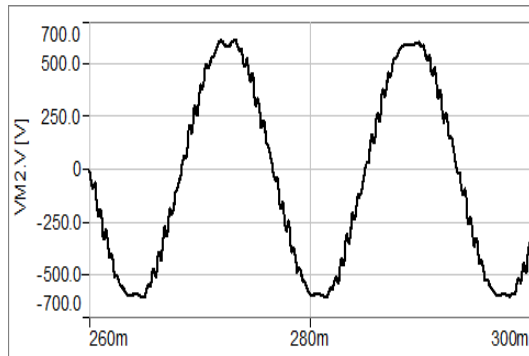

Typical filter output waveform when VFD switching frequency is set to 4kHz:

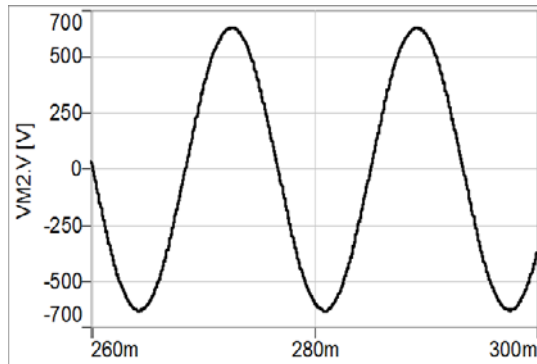

Typical filter output waveform when VFD switching frequency is set to 8kHz:

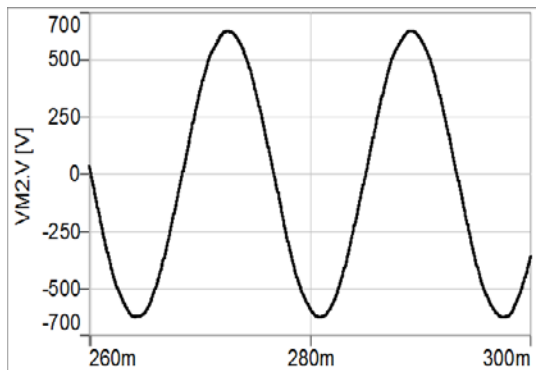

### 8.3 Sinewave Filter Kits – 480V

Mangoldt PolyGap Sinewave Filters are available as kits consisting of a single filter reactor plus the necessary capacitors. Capacitors are single phase types and are always used in multiples of 3 pieces. The same sinewave filter reactors may be used for both  $\geq 2\text{kHz}$  or  $>5\text{kHz}$  switching frequencies. Sinewave Filters must only be used with a VFD with a fixed carrier (switching) frequency and may not be used with a variable carrier frequency.

#### 8.3.a Switching frequency $\geq 2\text{kHz}$ :

These kits use the standard PolyGap® sinewave filter reactor (Type PSD53) plus the appropriate capacitors that are suitable for switching (carrier) frequency of 2kHz and higher. These filters require a larger capacitor value than the filters intended for use at a switching frequency of 5kHz or higher. Sinewave filters may be damaged if mis-applied.

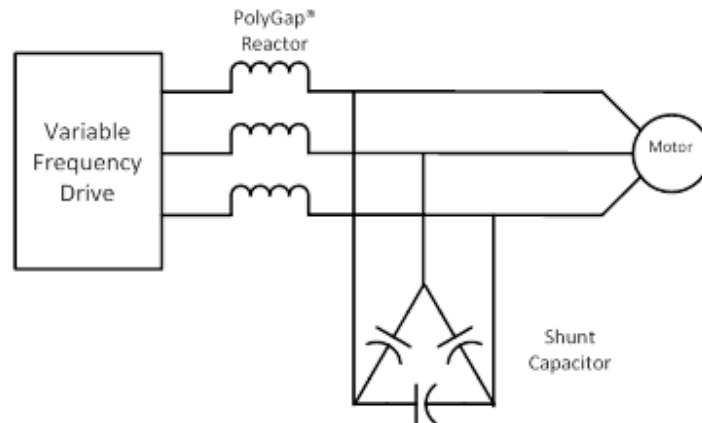

#### 8.3.b Switching frequency $\geq 5\text{kHz}$ :

These kits use the standard PolyGap® sinewave filter reactor (Type PSD53) plus the appropriate capacitors that are suitable for switching (carrier) frequency of 5kHz and higher. These filters require a smaller capacitor value than the filters intended for use at a switching frequency of 2kHz or higher. These filters offer a more economical solution whenever the VFD will be set to a fixed switching frequency of 5kHz or higher. These filters may not be used at switching frequencies lower than 5kHz. Sinewave filters may be damaged if mis-applied.

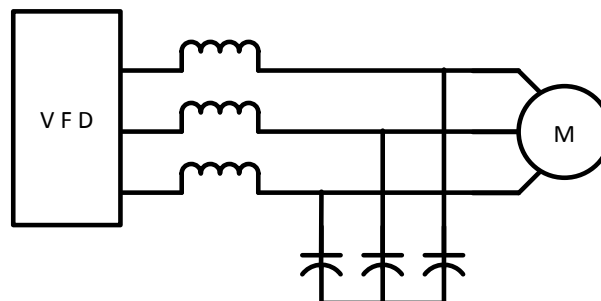

### 8.4 Technical Data for Standard SINEWAVE FILTERS – 480V, $f_{sw} \geq 2\text{kHz}$

For factory assembled PolyGap® Sinewave Filters

Filter Cat. No.	Arms	HP	kW	mH	uF	Terminal	Watts Loss	Weight kg/lbs
PSF53-0005	5	3	2.2	14.5	1.5	term. blk	45	6.4 / 14
PSF53-0008	8	5	3.7	9	2.2	term. blk	70	7.6 / 17
PSF53-0011	11	7.5	5.6	6.5	3	term. blk	90	10.8 / 24
PSF53-0015	15	10	7.5	4.8	4.7	term. blk	110	12.7 / 28
PSF53-0021	21	15	11	3.4	6.8	term. blk	140	15.8 / 35
PSF53-0027	27	20	15	2.7	6.8	Cu bar	170	23.8 / 52
PSF53-0035	35	25	19	2	10	Cu bar	180	24.4 / 54
PSF53-0040	40	30	22	1.8	10	Cu bar	220	28.9 / 64
PSF53-0052	52	40	30	1.38	15	Cu bar	260	30.9 / 68
PSF53-0065	65	50	37.3	1.1	20	Cu bar	310	41.5 / 91
PSF53-0077	77	60	45	0.93	20	Cu bar	350	40.4 / 89
PSF53-0100	100	75	56	0.72	33	Cu bar	410	58.7 / 129
PSF53-0125	125	100	75	0.57	33	Cu bar	450	68.9 / 152
PSF53-0156	156	125	93	0.46	47	Cu bar	550	78.4 / 172
PSF53-0187	187	150	112	0.39	47	Cu bar	620	91.9 / 202
PSF53-0240	240	200	149	0.3	66	Cu bar	850	121 / 266
PSF53-0302	302	250	187	0.24	94	Cu bar	935	158 / 348
PSF53-0361	361	300	224	0.2	94	Cu bar	1050	175 / 385
PSF53-0420	420	350	261	0.17	94	Cu bar	1200	195 / 429
PSF53-0480	480	400	298	0.15	141	Cu bar	1350	216 / 475
PSF53-0520	520	450	336	0.138	141	Cu bar	1400	244 / 537
PSF53-0590	590	500	373	0.12	141	Cu bar	1500	259 / 570
PSF53-0720	720	600	448	0.1	188	Cu bar	1750	302 / 664
PSF53-0840	840	700	522	0.085	188	Cu bar	1850	338 / 744
PSF53-1000	1000	850	634	0.07	282	Cu bar	2650	415 / 913
PSF53-1220	1220	1000	746	0.06	282	Cu bar	3100	469 / 1032
PSF53-1460	1460	1200	895	0.05	376	Cu bar	3500	565 / 1243

## 8.5 Technical Data for Standard SINEWAVE FILTER KITS – 480V, $f_{sw} \geq 2\text{kHz}$ KITS

For PolyGap® Sinewave Filter KITS

This table lists the components provided in a Sinewave Filter KIT ( $f_{sw} \geq 2\text{kHz}$  filters) using the standard PSD53 reactors. All filters must have capacitors connected in DELTA configuration per diagram 8.4.a on page 32.

Reactor Cat. No.	Arms	mH	Terminal	Watts Loss	QTY	CAPACITORS	uF
PSD53-0005	5	14.5	term. blk	45	3	LKT-F-001.5-1-1200-BA	1.5
PSD53-0008	8	9	term. blk	70	3	LKT-F-002.2-1-1200-BA	2.2
PSD53-0011	11	6.5	term. blk	90	3	LKT-F-003.0-1-1200-BA	3.0
PSD53-0015	15	4.8	term. blk	110	3	LKT-F-004.5-1-1200-BA	4.5
PSD53-0021	21	3.4	term. blk	140	3	LKT-F-006.8-1-1200-BA	6.8
PSD53-0027	27	2.7	Cu bar	170	3	LKT-F-006.8-1-1200-BA	6.8
PSD53-0035	35	2	Cu bar	180	3	LKT-F-010.0-1-1200-BB	10
PSD53-0040	40	1.8	Cu bar	220	3	LKT-F-010.0-1-1200-BB	10
PSD53-0052	52	1.38	Cu bar	260	3	LKT-F-015.0-1-1200-BB	15
PSD53-0065	65	1.1	Cu bar	310	3	LKT-F-020.0-1-1200-BB	20
PSD53-0077	77	0.93	Cu bar	350	3	LKT-F-020.0-1-1200-BH	20
PSD53-0100	100	0.72	Cu bar	410	3	LKT-F-035.0-1-1200-BH	35
PSD53-0125	125	0.57	Cu bar	450	3	LKT-F-035.0-1-1200-BH	35
PSD53-0156	156	0.46	Cu bar	550	3	LKT-F-045.0-1-1200-BI	45
PSD53-0187	187	0.39	Cu bar	620	3	LKT-F-045.0-1-1200-BI	45
PSD53-0240	240	0.3	Cu bar	850	3 3	LKT-F-045.0-1-1200-BI LKT-F-020.0-1-1200-BH	65
PSD53-0302	302	0.24	Cu bar	935	3 3	LKT-F-050.0-1-1200-BI LKT-F-045.0-1-1200-BI	95
PSD53-0361	361	0.2	Cu bar	1050	3 3	LKT-F-050.0-1-1200-BI LKT-F-045.0-1-1200-BI	95
PSD53-0420	420	0.17	Cu bar	1200	3 3	LKT-F-050.0-1-1200-BI LKT-F-045.0-1-1200-BI	95
PSD53-0480	480	0.15	Cu bar	1350	3 6	LKT-F-050.0-1-1200-BI LKT-F-045.0-1-1200-BI	140
PSD53-0520	520	0.138	Cu bar	1400	3 6	LKT-F-050.0-1-1200-BI LKT-F-045.0-1-1200-BI	140
PSD53-0590	590	0.12	Cu bar	1500	3 6	LKT-F-050.0-1-1200-BI LKT-F-045.0-1-1200-BI	140
PSD53-0720	720	0.1	Cu bar	1750	6 6	LKT-F-050.0-1-1200-BI LKT-F-045.0-1-1200-BI	190
PSD53-0840	840	0.085	Cu bar	1850	6 6	LKT-F-050.0-1-1200-BI LKT-F-045.0-1-1200-BI	190
PSD53-1000	1000	0.07	Cu bar	2650	12 3	LKT-F-060.0-1-1200-BJ LKT-F-045.0-1-1200-BI	285
PSD53-1220	1220	0.06	Cu bar	3100	12 3	LKT-F-060.0-1-1200-BJ LKT-F-045.0-1-1200-BI	285
PSD53-1460	1460	0.05	Cu bar	3500	18 3	LKT-F-060.0-1-1200-BJ LKT-F-015.0-1-1200-BB	375

**8.5.a Reactors for Sinewave Filter Kits – 480V (for both  $f_{sw} \geq 2\text{kHz}$  and  $f_{sw} \geq 5\text{kHz}$ )**

Motor Ratings		Reactor	Reactor Data		Dimensions (inches)			Weight	
					width	height	depth		
HP	Amax	Catalog No.	mH	Watts	A	B	C	kg	Lbs
3	5	PSD53-0005	14.5	45	7.01	7.41	3.86	6.4	14.08
5	8	PSD53-0008	9	70	8.63	8.43	3.94	7.6	16.72
7.5	11	PSD53-0011	6.5	90	8.63	8.47	4.73	10.8	23.76
10	15	PSD53-0015	4.8	110	9.57	9.18	4.73	12.7	27.94
15	21	PSD53-0021	3.6	160	9.57	9.49	5.2	15.8	34.76
20	27	PSD53-0027	2.7	170	12.45	9.81	6.46	23.8	52.36
25	35	PSD53-0035	2	195	11.46	8.35	8.12	24.4	53.68
30	40	PSD53-0040	1.8	220	12.45	9.1	8.15	28.9	63.58
40	52	PSD53-0052	1.38	320	12.45	9.85	8.39	30.9	67.98
50	65	PSD53-0065	1.1	310	13.86	9.22	9.45	41.5	91.3
60	77	PSD53-0077	0.93	350	13.86	10.48	9.06	40.4	88.88
75	100	PSD53-0100	0.72	420	14.18	12.37	9.49	58.7	129.14
100	125	PSD53-0125	0.57	450	14.18	12.37	10.2	68.9	151.58
125	156	PSD53-0156	0.46	770	16.54	14.53	9.89	75.7	166.54
150	187	PSD53-0187	0.39	620	16.54	14.45	10.6	91.9	202.18
200	240	PSD53-0240	0.3	850	16.54	18.51	12.21	121	266.2
250	302	PSD53-0302	0.24	930	16.54	20.08	13.47	143	314.6
300	361	PSD53-0361	0.2	1150	16.54	20.16	14.73	175	385
350	420	PSD53-0420	0.17	1200	16.54	22.76	16.5	195	429
400	480	PSD53-0480	0.15	1350	18.9	25.2	15.79	216	475.2
450	520	PSD53-0520	0.138	1300	18.9	23.75	16.66	244	536.8
500	590	PSD53-0590	0.12	1500	18.9	25.12	16.93	259	569.8
600	720	PSD53-0720	0.1	1750	18.9	29.26	17.13	302	664.4
700	840	PSD53-0840	0.085	1850	18.9	29.45	18.43	338	743.6
850	1000	PSD53-1000	0.07	3050	21.66	35.75	19.1	415	913
1000	1220	PSD53-1220	0.06	3400	21.66	36.23	19.61	468	1029.6
1200	1460	PSD53-1460	0.05	4050	21.66	36.66	17.88	564	1240.8

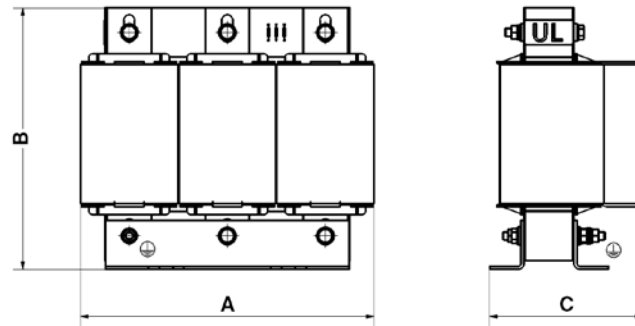

### 8.6 Technical Data for SINEWAVE FILTER KITS – 480V, $f_{sw} \geq 5\text{kHz}$

This table lists the components provided in a Sinewave Filter KIT ( $f_{sw} \geq 5\text{kHz}$  filters) using the standard PSD53 reactors. Units in RED must have capacitors connected in wye configuration per 5kHz diagram on page 32. All others are to be connected in delta configuration.

Cat. No.	Arms	mH	Terminal	Watts Loss	QTY	CAPACITORS	uF
<i>PSD53-0005</i>	<i>5</i>	<i>14.5</i>	<i>term. blk</i>	<i>45</i>	<i>3</i>	<i>LKT-F-001.0-1-1200-BA</i>	<i>1</i>
<i>PSD53-0008</i>	<i>8</i>	<i>9</i>	<i>term. blk</i>	<i>70</i>	<i>3</i>	<i>LKT-F-001.5-1-1200-BA</i>	<i>1.5</i>
<i>PSD53-0011</i>	<i>11</i>	<i>6.5</i>	<i>term. blk</i>	<i>90</i>	<i>3</i>	<i>LKT-F-002.2-1-1200-BA</i>	<i>2.2</i>
PSD53-0015	15	4.8	term blk	110	3	LKT-F-001.0-1-1200-BA	3
PSD53-0021	21	3.4	term. blk	140	3	LKT-F-001.5-1-1200-BA	4.5
PSD53-0027	27	2.7	Cu bar	170	3	LKT-F-001.5-1-1200-BA	4.5
PSD53-0035	35	2	Cu bar	180	3	LKT-F-002.2-1-1200-BA	6.6
PSD53-0040	40	1.8	Cu bar	220	3	LKT-F-002.2-1-1200-BA	6.6
PSD53-0052	52	1.38	Cu bar	260	3	LKT-F-003.0-1-1200-BA	9
PSD53-0065	65	1.1	Cu bar	310	3	LKT-F-003.3-1-1200-BA	9.9
PSD53-0077	77	0.93	Cu bar	350	3	LKT-F-004.5-1-1200-BA	13.5
PSD53-0100	100	0.72	Cu bar	410	3	LKT-F-006.8-1-1200-BA	20.4
PSD53-0125	125	0.57	Cu bar	450	3	LKT-F-007.1-1-1200-BA	21.3
PSD53-0156	156	0.46	Cu bar	550	3	LKT-F-010.0-1-1200-BB	30
PSD53-0187	187	0.39	Cu bar	620	3	LKT-F-010.0-1-1200-BB	30
PSD53-0240	240	0.3	Cu bar	850	3	LKT-F-015.0-1-1200-BB	45
PSD53-0302	302	0.24	Cu bar	935	3	LKT-F-015.0-1-1200-BB	45
PSD53-0361	361	0.2	Cu bar	1050	3	LKT-F-020.0-1-1200-BB	60
PSD53-0420	420	0.17	Cu bar	1200	3	LKT-F-025.0-1-1200-BH	75
PSD53-0480	480	0.15	Cu bar	1350	3	LKT-F-025.0-1-1200-BH	75
PSD53-0520	520	0.138	Cu bar	1400	3	LKT-F-035.0-1-1200-BH	105
PSD53-0590	590	0.12	Cu bar	1500	3	LKT-F-035.0-1-1200-BH	105
PSD53-0720	720	0.1	Cu bar	1750	3	LKT-F-045.0-1-1200-BI	135
PSD53-0840	840	0.085	Cu bar	1850	3	LKT-F-045.0-1-1200-BI	135
PSD53-1000	1000	0.07	Cu bar	2650	3	LKT-F-060.0-1-1200-BJ	180
PSD53-1220	1220	0.06	Cu bar	3100	3 3	LKT-F-020.0-1-1200-BH LKT-F-045.0-1-1200-BI	195
PSD53-1460	1460	0.05	Cu bar	3500	3 3	LKT-F-035.0-1-1200-BH LKT-F-045.0-1-1200-BI	240

### 8.6.a Reactors for Sinewave Filter Kits – 480V (for both $f_{sw} \geq 2\text{kHz}$ and $f_{sw} \geq 5\text{kHz}$ )

Motor Ratings		Reactor	Reactor Data		Dimensions (inches)			Weight	
					width	height	depth		
HP	Amax	Catalog No.	mH	Watts	A	B	C	kg	Lbs
3	5	PSD53-0005	14.5	45	7.01	7.41	3.86	6.4	14.08
5	8	PSD53-0008	9	70	8.63	8.43	3.94	7.6	16.72
7.5	11	PSD53-0011	6.5	90	8.63	8.47	4.73	10.8	23.76
10	15	PSD53-0015	4.8	110	9.57	9.18	4.73	12.7	27.94
15	21	PSD53-0021	3.6	160	9.57	9.49	5.2	15.8	34.76
20	27	PSD53-0027	2.7	170	12.45	9.81	6.46	23.8	52.36
25	35	PSD53-0035	2	195	11.46	8.35	8.12	24.4	53.68
30	40	PSD53-0040	1.8	220	12.45	9.1	8.15	28.9	63.58
40	52	PSD53-0052	1.38	320	12.45	9.85	8.39	30.9	67.98
50	65	PSD53-0065	1.1	310	13.86	9.22	9.45	41.5	91.3
60	77	PSD53-0077	0.93	350	13.86	10.48	9.06	40.4	88.88
75	100	PSD53-0100	0.72	420	14.18	12.37	9.49	58.7	129.14
100	125	PSD53-0125	0.57	450	14.18	12.37	10.2	68.9	151.58
125	156	PSD53-0156	0.46	770	16.54	14.53	9.89	75.7	166.54
150	187	PSD53-0187	0.39	620	16.54	14.45	10.6	91.9	202.18
200	240	PSD53-0240	0.3	850	16.54	18.51	12.21	121	266.2
250	302	PSD53-0302	0.24	930	16.54	20.08	13.47	143	314.6
300	361	PSD53-0361	0.2	1150	16.54	20.16	14.73	175	385
350	420	PSD53-0420	0.17	1200	16.54	22.76	16.5	195	429
400	480	PSD53-0480	0.15	1350	18.9	25.2	15.79	216	475.2
450	520	PSD53-0520	0.138	1300	18.9	23.75	16.66	244	536.8
500	590	PSD53-0590	0.12	1500	18.9	25.12	16.93	259	569.8
600	720	PSD53-0720	0.1	1750	18.9	29.26	17.13	302	664.4
700	840	PSD53-0840	0.085	1850	18.9	29.45	18.43	338	743.6
850	1000	PSD53-1000	0.07	3050	21.66	35.75	19.1	415	913
1000	1220	PSD53-1220	0.06	3400	21.66	36.23	19.61	468	1029.6
1200	1460	PSD53-1460	0.05	4050	21.66	36.66	17.88	564	1240.8

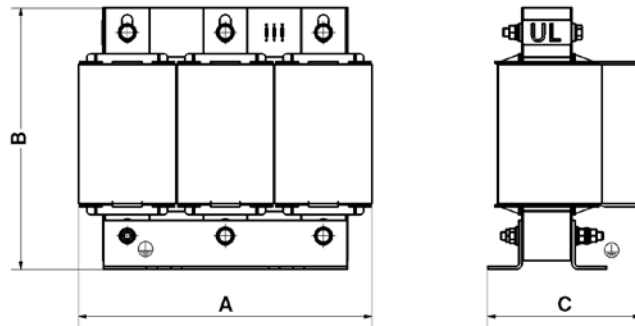

### 9.1.6 Capacitors for 480V Sinewave Filter KITS (60/70mm diameter)

Capacitors with diameter of 60mm or 70mm

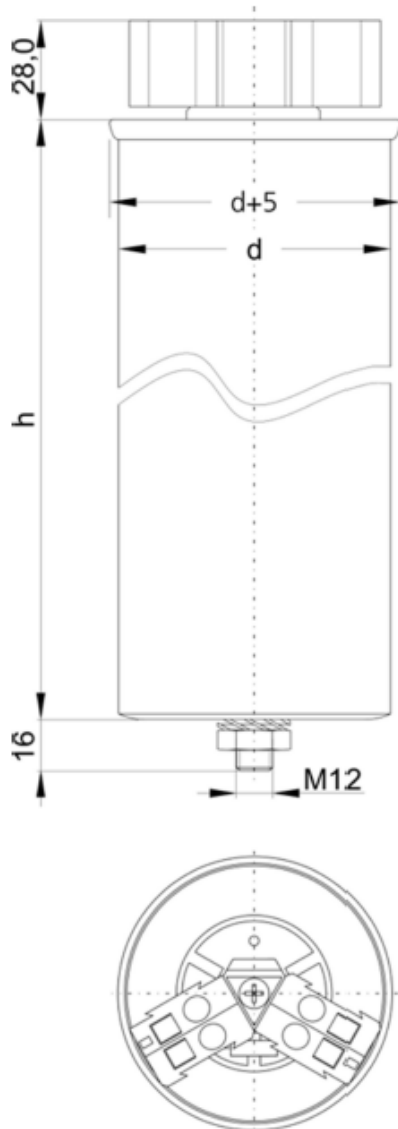

60/70mm Capacitors	Datasheet
LKT-F-001.0-1-1200-BA	31-13036
LKT-F-001.5-1-1200-BA	31-13037
LKT-F-002.2-1-1200-BA	31-13038
LKT-F-003.0-1-1200-BA	31-13039
LKT-F-003.3-1-1200-BA	31-13040
LKT-F-004.5-1-1200-BA	31-13041
LKT-F-006.8-1-1200-BA	31-13042
LKT-F-007.1-1-1200-BA	31-13043
LKT-F-010.0-1-1200-BB	31-13044
LKT-F-015.0-1-1200-BB	31-13045

**Wire capacity: 2x (16-10 awg) solid, stranded, flexible, ferrule**

**Mounting stud torque: 15 Nm**

**Factory installed discharge resistors.**

### 9.1.7 Capacitors for 480V Sinewave Filters (85mm diameter)

Capacitors with diameter of 85mm

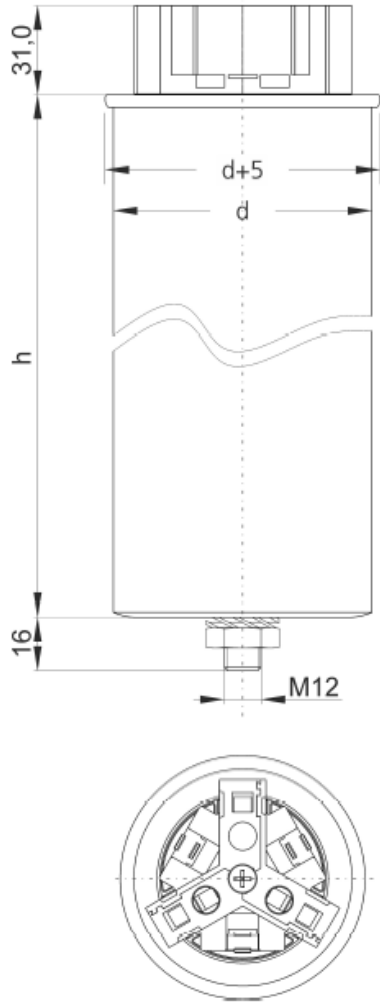

85mm Capacitors	Datasheet
LKT-F-020.0-1-1200-BH	31-13063
LKT-F-025.0-1-1200-BH	31-13064
LKT-F-035.0-1-1200-BH	31-13065
LKT-F-045.0-1-1200-BI	31-13066
LKT-F-050.0-1-1200-BI	31-13067
LKT-F-060.0-1-1200-BJ	31-13068

**Wire capacity: 1x (14-6 awg) solid, stranded, flexible, ferrule**

**Mounting stud torque: 15 Nm**

**Factory installed discharge resistors.**

### 9.1.7 Capacitor Wiring

FRAKO filter capacitors are produced with the popular Wago cage clamp for secure maintenance free connections.



The WAGO CAGE CLAMP®

FRAKO filter capacitors, using Wago cage clamps are suitable for a variety of conductor types.

The CAGE CLAMP® is suitable for:



Solid



Stranded



Flexible



Flexible with  
Ferrule



Flexible with  
Pin Terminal

Connections can be made easily to the capacitor terminals using only a terminal actuator (screwdriver). The connection is screwless, so there is no concern about loosening of terminals as is experienced with screw type terminals over time.



Insert a flat-slotted screwdriver into the clamp actuator



Press the screwdriver into



To open the clamp shift back the screwdriver and push in the stripped wire



Remove the screwdriver



Check the fixing of the wire

### 9.2.4.a Capacitors for Standard Sinewave Filter (KITS) – 480V; $f_c \geq 2\text{kHz}$

Motor Ratings		Capacitor(s)		Capacitor Data		Dimensions (inches)		Weight (individual)	
						Diameter	height	kg	Lbs
HP	Amax	Qty Req'd	Catalog No.	3x uF ( $\Delta$ )	Watts	d	h	kg	Lbs
3	5	3	LKT-F-001.5-1-1200-BA	1.5		2.37	3.55	0.355	0.781
5	8	3	LKT-F-002.2-1-1200-BA	2.2		2.37	3.55	0.355	0.781
7.5	11	3	LKT-F-003.0-1-1200-BA	3		2.37	3.55	0.355	0.781
10	15	3	LKT-F-004.5-1-1200-BA	4.5		2.37	3.55	0.355	0.781
15	21	3	LKT-F-006.8-1-1200-BA	6.8		2.37	3.55	0.355	0.781
20	27	3	LKT-F-006.8-1-1200-BA	6.8		2.37	3.55	0.355	0.781
25	35	3	LKT-F-010.0-1-1200-BB	10		2.37	5.44	0.53	1.166
30	40	3	LKT-F-010.0-1-1200-BB	10		2.37	5.44	0.53	1.166
40	52	3	LKT-F-015.0-1-1200-BB	15		2.37	5.44	0.53	1.166
50	65	3	LKT-F-020.0-1-1200-BH	20		3.35	5.16	1.2	2.64
60	77	3	LKT-F-020.0-1-1200-BH	20		3.35	5.16	1.2	2.64
75	100	3	LKT-F-035.0-1-1200-BH	35		3.35	5.16	1.2	2.64
100	125	3	LKT-F-035.0-1-1200-BH	35		3.35	5.16	1.2	2.64
125	156	3	LKT-F-045.0-1-1200-BI	45		3.35	6.42	1.2	2.64
150	187	3	LKT-F-045.0-1-1200-BI	45		3.35	6.42	1.2	2.64
200	240	3	LKT-F-020.0-1-1200-BH	20		3.35	5.16	1.2	2.64
		3	LKT-F-045.0-1-1200-BI	45		3.35	6.42	1.2	2.64
250	302	3	LKT-F-045.0-1-1200-BI	45		3.35	6.42	1.2	2.64
		3	LKT-F-050.0-1-1200-BI	50		3.35	6.42	1.2	2.64
300	361	3	LKT-F-045.0-1-1200-BI	45		3.35	6.42	1.2	2.64
		3	LKT-F-050.0-1-1200-BI	50		3.35	6.42	1.2	2.64
350	420	3	LKT-F-045.0-1-1200-BI	45		3.35	6.42	1.2	2.64
		3	LKT-F-050.0-1-1200-BI	50		3.35	6.42	1.2	2.64
400	480	6	LKT-F-045.0-1-1200-BI	45		3.35	6.42	1.2	2.64
		3	LKT-F-050.0-1-1200-BI	50		3.35	6.42	1.2	2.64
450	520	6	LKT-F-045.0-1-1200-BI	45		3.35	6.42	1.2	2.64
		3	LKT-F-050.0-1-1200-BI	50		3.35	6.42	1.2	2.64
500	590	6	LKT-F-045.0-1-1200-BI	45		3.35	6.42	1.2	2.64
		3	LKT-F-050.0-1-1200-BI	50		3.35	6.42	1.2	2.64
600	720	6	LKT-F-045.0-1-1200-BI	45		3.35	6.42	1.2	2.64
		6	LKT-F-050.0-1-1200-BI	50		3.35	6.42	1.2	2.64
700	840	6	LKT-F-045.0-1-1200-BI	45		3.35	6.42	1.2	2.64
		6	LKT-F-050.0-1-1200-BI	50		3.35	6.42	1.2	2.64
850	1000	3	LKT-F-045.0-1-1200-BI	45		3.35	6.42	1.2	2.64
		12	LKT-F-060.0-1-1200-BJ	60		3.35	8.47	1.55	3.41
1000	1220	3	LKT-F-045.0-1-1200-BI	45		3.35	6.42	1.2	2.64
		12	LKT-F-060.0-1-1200-BJ	60		3.35	8.47	1.55	3.41
1200	1460	3	LKT-F-025.0-1-1200-BH	25		3.35	5.16	1.2	2.64
		3	LKT-F-050.0-1-1200-BI	50		3.35	6.42	1.2	2.64
		15	LKT-F-060.0-1-1200-BJ	60		3.35	8.47	1.55	3.41

Cat. No.	Arms	Wire size	Qty	CAPACITORS	Arms Per Capacitor	Awg Per capacitor
PSD53-0005	5	12 awg	3x	LKT-F-001.5-1-1200-BA	15	12 awg
PSD53-0008	8	12 awg	3x	LKT-F-002.2-1-1200-BA	15	12 awg
PSD53-0011	11	12 awg	3x	LKT-F-003.0-1-1200-BA	15	12 awg
PSD53-0015	15	12 awg	3x	LKT-F-004.5-1-1200-BA	15	12 awg
PSD53-0021	21	10 awg	3x	LKT-F-006.8-1-1200-BA	15	12 awg
PSD53-0027	27	10 awg	3x	LKT-F-006.8-1-1200-BA	15	12 awg
PSD53-0035	35	8 awg	3x	LKT-F-010.0-1-1200-BB	22	10 awg
PSD53-0040	40	8 awg	3x	LKT-F-010.0-1-1200-BB	22	10 awg
PSD53-0052	52	6 awg	3x	LKT-F-015.0-1-1200-BB	22	10 awg
PSD53-0065	65	4 awg	3x	LKT-F-020.0-1-1200-BH	40	8 awg
PSD53-0077	77	2 awg	3x	LKT-F-020.0-1-1200-BH	40	8 awg
PSD53-0100	100	1 awg	3x	LKT-F-035.0-1-1200-BH	40	8 awg
PSD53-0125	125	2/0 awg	3x	LKT-F-035.0-1-1200-BH	40	8 awg
PSD53-0156	156	3/0 awg	3x	LKT-F-045.0-1-1200-BI	45	6 awg
PSD53-0187	187	250kcmil	3x	LKT-F-045.0-1-1200-BI	45	6 awg
PSD53-0240	240	350kcmil	3x	LKT-F-020.0-1-1200-BB	20	8 awg
			3x	LKT-F-045.0-1-1200-BI	45	6 awg
PSD53-0302	302	500kcmil	3x	LKT-F-045.0-1-1200-BI	45	6 awg
			3x	LKT-F-050.0-1-1200-BI	50	6 awg
PSD53-0361	361	700kcmil	3x	LKT-F-045.0-1-1200-BI	45	6 awg
			3x	LKT-F-050.0-1-1200-BI	50	6 awg
PSD53-0420	420	1000kcmil	3x	LKT-F-045.0-1-1200-BI	45	6 awg
			3x	LKT-F-050.0-1-1200-BI	50	6 awg
PSD53-0480	480	1500kcmil	6x	LKT-F-045.0-1-1200-BI	45	6 awg
			3x	LKT-F-050.0-1-1200-BI	45	6 awg
PSD53-0520	520	1750kcmil	6x	LKT-F-045.0-1-1200-BI	45	6 awg
			3x	LKT-F-050.0-1-1200-BI	45	6 awg
PSD53-0590	590	Parallel to suit	6x	LKT-F-045.0-1-1200-BI	45	6 awg
			3x	LKT-F-050.0-1-1200-BI	45	6 awg
PSD53-0720	720	Parallel to suit	6x	LKT-F-045.0-1-1200-BI	45	6 awg
			6x	LKT-F-050.0-1-1200-BI	45	6 awg
PSD53-0840	840	Parallel to suit	6x	LKT-F-045.0-1-1200-BI	45	6 awg
			6x	LKT-F-050.0-1-1200-BI	45	6 awg
PSD53-1000	1000	Parallel to suit	3x	LKT-F-045.0-1-1200-BI	45	6 awg
			12x	LKT-F-060.0-1-1200-BJ	50	6 awg
PSD53-1220	1220	Parallel to suit	3x	LKT-F-045.0-1-1200-BI	45	6 awg
			12x	LKT-F-060.0-1-1200-BJ	50	6 awg
PSD53-1460	1460	Parallel to suit	3x	LKT-F-025.0-1-1200-BH	40	8 awg
			3x	LKT-F-050.0-1-1200-BI	45	6 awg
			15x	LKT-F-060.0-1-1200-BJ	50	6 awg

**Wire sizes are based on 75°C rated conductor insulation, 30°C ambient and not more than three current carrying conductors in a raceway, where paralleled conductors are used, the installation must adhere to NFPA 70 Article 310, 310.10.G2 and 310.15.C1.**

	INSTALLATION, OPERATION AND MAINTENANCE MANUAL FOR LOW VOLTAGE PolyGap® Sinewave Filters	August 27, 2021
--	---------------------------------------------------------------------------------------------------	-----------------

## 10.0 Maintenance

Generally, the PolyGap® Sinewave Filters are considered to be maintenance free. During the course of normal operation, the capacitor cells will experience minor levels of expansion and contraction due to fluctuations in operating and ambient temperatures.

The following inspections should be made during regular station maintenance intervals.

- Periodically inspect the individual capacitor cells for bulging. If the top (terminal area) is bulging, then it is likely that the pressure switch has opened and the capacitor is no longer operational. Any failed capacitor cells should be replaced with direct factory replacements.
- Remove any dust that may have accumulated within your filter cabinet and in air inlets and outlets.
- Routinely check torque on all reactor terminations. Verify they are according to the specifications.

## 11.0 Troubleshooting Guide

### 11.1 Troubleshooting Guide – VFD output Applications

Symptom	Problem	Solution
Output voltage distortion is above 5% THD-v	Improper connection	Check all component connections and confirm that reactors and capacitors are wired correctly.
	Failed capacitor(s)	Check each capacitor for a bulge on the top (terminal end) of capacitor. If bulge is present, capacitor pressure switch activated and capacitor can no longer be used. Replace only with exact FRAKO capacitor.
Output voltage is low	Capacitors not connected or failed	Verify that the proper ratings and quantity of capacitors are in use and that all capacitors are properly connected.
Output voltage is high	Filter is too large for actual load	Verify correct rating of filter based on actual load rating.
Phase currents are not balanced	Failed capacitor or low capacitance	Identify failed capacitor (look for bulge at top) and replace using exact replacement.
VFD trips on over-current	Improper connection	Filter may be connected backwards in the VFD output circuit. Reconnect sinewave filter so reactor is the reactor is electrically closest to the drive, capacitor on motor side of filter
VFD trips on over-current	ACCEL rate is too fast	Adjust acceleration rate to a slower time (start by setting to $\geq 5$ seconds, then if desired to have a faster rate, decrease by one seconds at a time but still checking to make sure the drive does not trip).

	INSTALLATION, OPERATION AND MAINTENANCE MANUAL FOR LOW VOLTAGE PolyGap® Sinewave Filters	August 27, 2021
--	---------------------------------------------------------------------------------------------------	-----------------

**Notes:**

	INSTALLATION, OPERATION AND MAINTENANCE MANUAL FOR LOW VOLTAGE PolyGap® Sinewave Filters	August 27, 2021
--	---------------------------------------------------------------------------------------------------	-----------------

## 12.0 Factory Support

**Mangoldt offers a variety of solutions for motor drive system power quality, including:**

**VFD Sinewave Filters**

**PWM to Sine Wave Filters**

**L-C-L Filters for active front end inverters**

**Line/Load Reactors**

We offer standard and custom solutions to meet your exact needs.

**For related technical papers and application notes, please visit our website at:**

**[www.mangoldt.com](http://www.mangoldt.com)**

**Order Placement:** To purchase new filters or replacement (spare) parts, please contact:

**Power Quality Components**  
W136N5239 Campbell Court  
Menomonee Falls, WI 53051  
Phone: 1-262-777-2360  
Fax: 1-262-783-5974  
sales@pqcomponents.com

**Technical Support:** For technical support and application engineering assistance, please contact:

**Power Quality Specialists**  
Allied Industrial Marketing, Inc.  
W67N222 Evergreen Boulevard, Suite 209  
Cedarburg, WI 53012  
Phone: 1-262-618-2403  
Fax: 1-262-618-2303  
info@alliedindustrialmarketing.com