

PSF Sine Wave Filters

Three-Phase, Iron-Core, PolyGap®-Design



MANGOLDT's PSF Sine Wave Filters provide proven performance and reliable high quality for your application

MANGOLDT'S Type PSF Sine Wave Filters set a new standard for Sine Wave Filter performance and reliability. The combination of precise three-phase reactors and high performance capacitors guarantees best-in-class motor protection and extended motor life-time.

Based on knowledge gained from several decades of applications experience as well as ongoing R&D they provide stable feature properties for your application. PolyGap® core technology is utilized for low power losses as well as balanced inductance. This leads to a superior lifetime of MANGOLDT PSF Sine Wave Filters. Sine Wave Filters from MANGOLDT are designed to suit both - line input or load output of drive systems. The modular design and its overall small dimensions make it easy to integrate and install them. They are designed for higher DC link voltages to assure proper function even within stressful applications like active front end drives (AFE) and motors for frequent regenerative braking.

Features

- Line and load side application
- PolyGap® Core Construction
- Vacuum and overpressure impregnation
- Balanced inductance in all three phases
- Low losses, especially due to harmonics

Benefits

- Provides a sinusoidal output voltage
- Guarantees trouble-free operation with longer motor cables (≤ 1500 m, shielded)
- Possible installation of filters in parallel
- Reduces discharge currents driven by pulse frequency in the case of long cable lengths
- Eliminates acoustic switching noise from the motor caused by magnetostriction
- Reduces high-frequency transient emissions
- Reduces bearing currents caused by circulating currents

Approvals / Standards

- CUL Listed (E173113),
- IEC/EN60076-6, VDE0532-76-6



Voltage Waveform

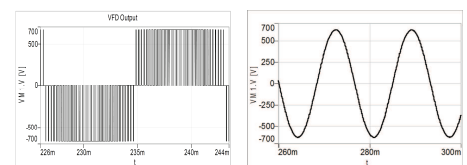

Without MANGOLDT PSF With MANGOLDT PSF

Current Waveform

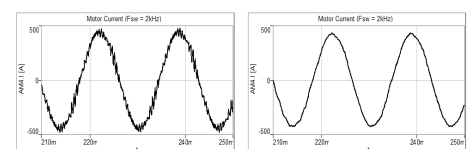

Without MANGOLDT PSF With MANGOLDT PSF

Technical Data			
Rated Voltage	$U_N / [V_{AC}]$	400...500	525...690
Rated Frequency*	$f_N / [Hz]$	0...80	0...70
Pulse Frequency	$f_{sw} / [kHz]$	2...10	1,5...10
Rated Currents	$I_N / [A_{RMS}]$	5...1460	5...1160
High Voltage Test	$U / [V_{AC}]$	3000 (1 min)	
Impulse Voltage Test	$U / [V_{peak}]$	4200	
Overload		$1.5 \times I_N$ for 60s/every 10min ($t_a \leq 45^\circ C$)	
Impregnation		Vacuum Overpressure (VPI)	
Insulation Class		T45/H	
Type of Cooling		Natural Convection (AN)	
Protection Class		IP00 (IP20/IP23/IP54 optional)	
Thermal Protection		Prepared - easy retrofit	
Altitude Maximum*		1000 Meters	
Relative Humidity		Maximum 95% non-condensing	

* without applied derating – for derating values consult Mangoldt

PSF53 Sine Wave Filters

Three-Phase, Iron-Core, PolyGap®-Design



Sine-Wave Filters utilize low-pass filter technology to suppress the pulse-frequency component from voltage-source frequency converters. The filter network suppresses the high-frequency content (pulses) from the Pulse-Width Modulated (PWM) voltage waveform, resulting in a nearly sinusoidal phase-to-phase output voltage. Due to the sinusoidal voltage supply, insulation stress and hysteresis thermal losses in the motor are reduced prolonging the lifetime of the motor. Sine-wave filters are considered to be the ideal solution for a large number of applications.

MANGOLDT PSF53 Sine Wave Filter Selection Table

Filter Type	Rated Current	Typical Motor Power Rating		Rated Inductance	Rated Capacitance	Terminal Input/Output	Typical Power Loss	Total Weight
	[A]	[kW] @500V	[hp] @480V	[mH]	[µF]		[W] @ 100% Load	
PSF53-0005	5	1,1/1,5	3	14,5	1,5	Terminal Blocks	45	6,4
PSF53-0008	8	2,2/3	5	9	2,2	Terminal Blocks	70	7,6
PSF53-0011	11	4	7,5	6,5	3	Terminal Blocks	90	10,8
PSF53-0015	15	5,5/7,5	10	4,8	4,7	Terminal Blocks	110	12,7
PSF53-0021	21	11	15	3,4	6,8	Terminal Blocks	140	15,8
PSF53-0027	27	12,5	20	2,7	6,8	Copper Bus Bar	170	23,8
PSF53-0035	35	15	25	2	10	Copper Bus Bar	195	24,4
PSF53-0040	40	18,5	30	1,8	10	Copper Bus Bar	220	28,9
PSF53-0052	52	22	40	1,38	15	Copper Bus Bar	260	30,9
PSF53-0065	65	30	50	1,1	20	Copper Bus Bar	310	41,5
PSF53-0077	77	37	60	0,93	20	Copper Bus Bar	350	40,4
PSF53-0100	100	45	75	0,72	33	Copper Bus Bar	410	58,7
PSF53-0125	125	55	100	0,57	33	Copper Bus Bar	450	68,9
PSF53-0156	156	75	125	0,46	47	Copper Bus Bar	550	78,4
PSF53-0187	187	90	150	0,39	47	Copper Bus Bar	620	91,9
PSF53-0240	240	110	200	0,3	66	Copper Bus Bar	850	121
PSF53-0302	302	132	250	0,24	94	Copper Bus Bar	935	158
PSF53-0360	360	160	300	0,2	94	Copper Bus Bar	1050	175
PSF53-0420	420	200	350	0,17	94	Copper Bus Bar	1200	195
PSF53-0480	480	250	400	0,15	141	Copper Bus Bar	1350	216
PSF53-0520	520	250	450	0,138	141	Copper Bus Bar	1400	244
PSF53-0590	590	315	500	0,12	141	Copper Bus Bar	1500	259
PSF53-0720	720	355	600	0,1	188	Copper Bus Bar	1750	302
PSF53-0840	840	400/450	700	0,085	188	Copper Bus Bar	1850	338
PSF53-1000	1000	500	850	0,07	282	Copper Bus Bar	2650	415
PSF53-1220	1220	560/630	1000	0,06	282	Copper Bus Bar	3100	469
PSF53-1460	1460	710/800	1200	0,05	376	Copper Bus Bar	3500	565

The range of applications of present VFD's is broadly diversified thereby making it difficult to find the proper solution for each specific drive system. In addition the drive system is not only affected by the application, but also by the VFD settings. We - MANGOLDT - have the aspiration to ease the product selection for our customers as much as possible. Please follow our Filter selection guide for further information, or consult our engineering team.

PSF53 Sine Wave Filters

Three-Phase, Iron-Core, PolyGap®-Design



The PSF product line is available as standard solution for several voltage ratings from 400V to 690V matching your application. For your specific demands MANGOLDT offers tailor-made solutions, our engineering team develops precise solutions to meet your specific application requirements.

PSF Sine Wave Filters can be used with most of the common motors and drives available on the global market. Even for short cable installations, at voltages higher than 500V Sine-Wave Filters are recommended for drive applications, to protect the motor winding insulation against high voltage peaks and to assure your best application performance.

Mechanical Data

Filter Type	A	B	C	D	E	F	H	D1	D2	Terminal		
	[mm]	[mm]	[mm]	[mm]	[mm]	[mm]	[mm]	[mm]	[mm]	[mm] ²	PE	[Nm]
PSF53-0005	178	188	136	146	106	69	89	7	12	0,2-4	0,2-4	0,5-0,8
PSF53-0008	219	214	149	181	136	70	100	10	16	0,2-4	0,2-4	0,5-0,8
PSF53-0011	219	215	169	181	136	90	120	10	16	0,2-4	0,2-4	0,5-0,8
PSF53-0015	243	233	164	205	156	85	115	10	16	0,5-10	0,2-4	1,5-1,8
PSF53-0021	243	242	179	205	156	95	125	10	16	1,5-16	0,5-10	2,5-3
PSF53-0027	316	195	250	278	200	125	164	10	16	30 x 5	M8	45
PSF53-0035	291	214	246	253	185	125	152	10	16	30 x 5	M8	45
PSF53-0040	316	235	250	278	200	125	164	10	16	30 x 5	M8	45
PSF53-0052	316	250	250	278	200	125	164	10	16	30 x 5	M8	45
PSF53-0065	352	241	285	314	224	140	184	10	16	30 x 5	M8	45
PSF53-0077	352	266	270	314	224	125	169	10	16	30 x 5	M8	45
PSF53-0100	360	314	297	300	-	141	177	10	13	30 x 5	M10	45
PSF53-0125	360	314	314	300	-	156	192	10	13	30 x 5	M10	45
PSF53-0156	420	369	330	350	-	152	192	12	18	30 x 5	M10	45
PSF53-0187	420	367	349	350	-	169	209	12	18	30 x 5	M10	45

5...21 A Types (Terminal Block)

35...187 A Types (Copper Bus Bars)

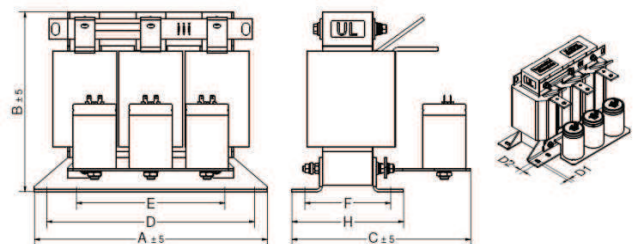
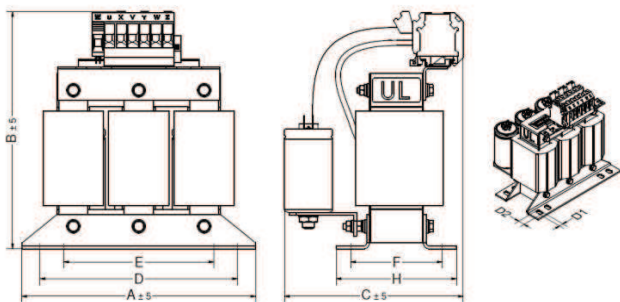

Mechanical Data

Filter Type	A	B	C	D	E	F	H	D1	D2	Terminal		
	[mm]	[mm]	[mm]	[mm]	[mm]	[mm]	[mm]	[mm]	[mm]	[mm] ²	PE	[Nm]
PSF53-0240	420	472	419	350	-	161	203	11	20	30 x 5	M10	45
PSF53-0302	420	506	444	350	-	176	218	11	20	40 x 5	M10	75
PSF53-0360	420	508	474	350	-	206	248	11	20	40 x 5	M12	75
PSF53-0420	420	568	474	350	-	206	248	11	20	40 x 5	M12	75
PSF53-0480	480	641	539	425	-	223	269	13	22	40 x 8	M12	75
PSF53-0520	480	607	563	425	-	253	299	13	22	40 x 8	M12	75
PSF53-0590	480	643	569	425	-	253	299	13	22	40 x 8	M12	75
PSF53-0720	480	748	524	425	-	253	299	13	22	40 x 8	M12	75
PSF53-0840	480	758	549	425	-	268	314	13	22	50 x 10	M12	75
PSF53-1000	550	912	575	475	-	265	319	17,5	30	80 x 6	M16	75
PSF53-1220	550	922	600	475	-	280	334	17,5	30	80 x 8	M16	75
PSF53-1460	550	931	720	475	-	315	369	17,5	30	80 x 10	M16	75

240...420 A Types (Copper Bus Bars)

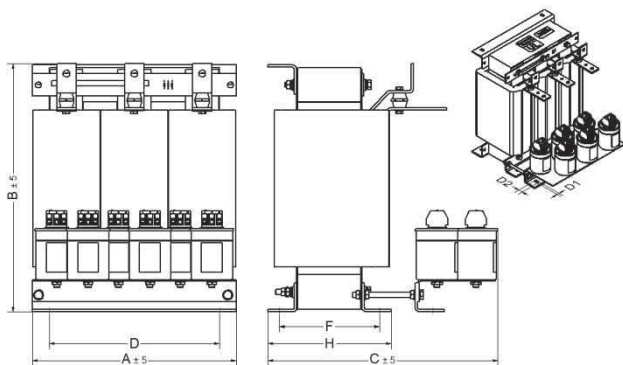

480...1460 A Types (Copper Bus Bars)

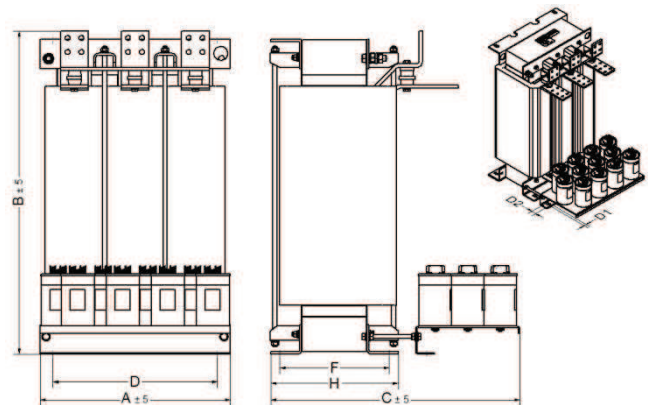

Bus Bar 20 mm

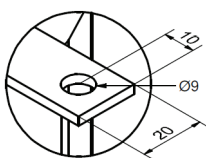

Bus Bar 30 mm

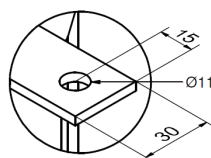

Bus Bar 40 mm

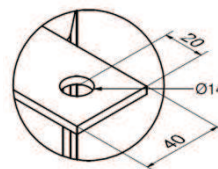

Bus Bar 50 mm

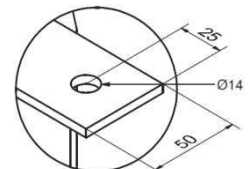

Bus Bar 60 mm

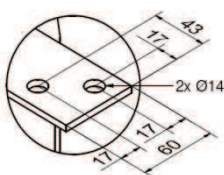

Bus Bar 80 mm

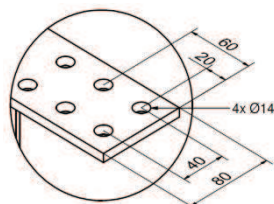

Connection Diagramm

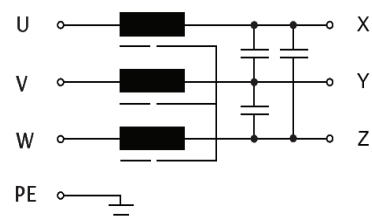

PSF63 Sine Wave Filters

Three-Phase, Iron-Core, PolyGap®-Design



Sine-Wave Filters utilize low-pass filter technology to suppress the pulse-frequency component from voltage-source frequency converters. The filter network suppresses the high-frequency content (pulses) from the Pulse-Width Modulated (PWM) voltage waveform, resulting in a nearly sinusoidal phase-to-phase output voltage. Due to the sinusoidal voltage supply, insulation stress and hysteresis thermal losses in the motor are reduced prolonging the lifetime of the motor. Sine-wave filters are considered to be the ideal solution for a large number of applications.

MANGOLDT PSF63 Sine Wave Filter Selection Table

Filter Type	Rated Current	Typical Motor Power Rating		Rated Inductance	Rated Capacitance	Terminal Input/Output	Typical Power Loss	Total Weight
	[A]	[kW] @690V	[hp] @600V	[mH]	[µF]		[W] @ 100% Load	
PSF63-0005	5	2,2/3	3	23	1,5	Terminal Blocks	80	7,1
PSF63-0007	7	4	5	17	2,2	Terminal Blocks	110	8,4
PSF63-0009	9	5,5	7,5	13	2,2	Terminal Blocks	125	11,7
PSF63-0012	12	7,5	10	10	3	Terminal Blocks	150	15,8
PSF63-0018	18	15/11	15	6,5	4,7	Terminal Blocks	190	22,8
PSF63-0027	27	18,5/22	20/25	4,3	6,8	Terminal Blocks	230	32,5
PSF63-0035	35	30	30	3,3	10	Terminal Blocks	300	41,8
PSF63-0042	42	37,5	40	2,8	10	Copper Bus Bar	375	50,6
PSF63-0055	55	45	50	2,1	15	Copper Bus Bar	470	62,1
PSF63-0065	65	55	60	1,8	15	Copper Bus Bar	520	
PSF63-0080	80	75	75	1,5	20	Copper Bus Bar	650	91,1
PSF63-0100	100	90	100	1,2	20	Copper Bus Bar	710	110
PSF63-0125	125	110	125	0,94	33	Copper Bus Bar	780	126
PSF63-0144	144	132	150	0,81	33	Copper Bus Bar	850	156
PSF63-0192	192	160	200	0,61	47	Copper Bus Bar	1050	183
PSF63-0242	242	200	250	0,48	66	Copper Bus Bar	1250	236
PSF63-0290	290	250	300	0,41	66	Copper Bus Bar	1500	253
PSF63-0340	340	315	350	0,35	94	Copper Bus Bar	1700	278
PSF63-0390	390	355	400	0,30	94	Copper Bus Bar	1850	326
PSF63-0480	480	450/500	450/500	0,24	141	Copper Bus Bar	2100	
PSF63-0580	580	560	600	0,2	141	Copper Bus Bar	2400	
PSF63-0680	680	630	700	0,17	141	Copper Bus Bar	2650	
PSF63-0780	780	710	750/800	0,15	200	Copper Bus Bar	2900	
PSF63-0880	880	800	850/900	0,13	200	Copper Bus Bar	3250	
PSF63-0960	960	900	1000	0,12	200	Copper Bus Bar	3500	
PSF63-1160	1160	1000	1200	0,1	300	Copper Bus Bar	4000	

The range of applications of present VFD's is broadly diversified thereby making it difficult to find the proper solution for each specific drive system. In addition the drive system is not only affected by the application, but also by the VFD settings. We - MANGOLDT - have the aspiration to ease the product selection for our customers as much as possible. Please follow our Filter selection guide for further information, or consult our engineering team.

PSF63 Sine Wave Filters

Three-Phase, Iron-Core, PolyGap®-Design



The PSF product line is available as standard solution for several voltage ratings from 400V to 690V matching your application. For your specific demands MANGOLDT offers tailor-made solutions, our engineering team develops precise solutions to meet your specific application requirements.

PSF Sine Wave Filters can be used with most of the common motors and drives available on the global market. Even for short cable installations, at voltages higher than 500V Sine-Wave Filters are recommended for drive applications, to protect the motor winding insulation against high voltage peaks and to assure your best application performance.

Mechanical Data

Filter Type	A	B	C	D	E	F	H	D1	D2	Terminal		
	[mm]	[mm]	[mm]	[mm]	[mm]	[mm]	[mm]	[mm]	[mm]	[mm] ²	PE	[Nm]
PSF63-0005												
PSF63-0007												
PSF63-0009												
PSF63-0012												
PSF63-0018												
PSF63-0027												
PSF63-0035												
PSF63-0042												
PSF63-0055												
PSF63-0065												
PSF63-0080												
PSF63-0100												
PSF63-0125												
PSF63-0144												
PSF63-0192												

5...35 A Types (Terminal Block)

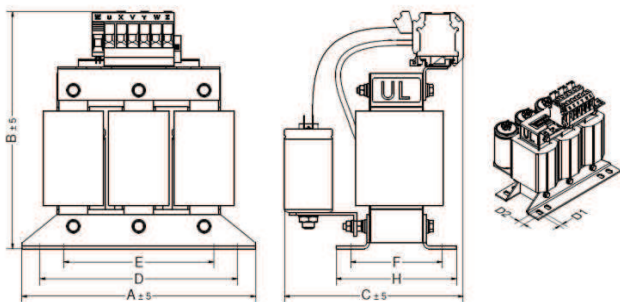

42...55 A Types (Copper Bus Bars)

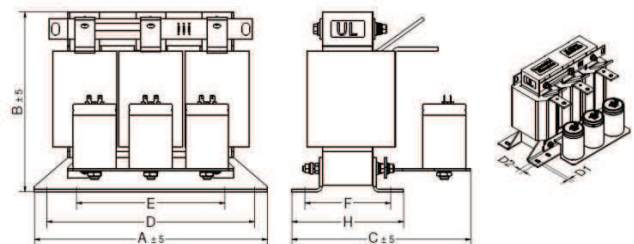

Mechanical Data

Filter Type	A	B	C	D	E	F	H	D1	D2	Terminal		
	[mm]	[mm]	[mm]	[mm]	[mm]	[mm]	[mm]	[mm]	[mm]	[mm] ²	PE	[Nm]
PSF63-0242												
PSF63-0290												
PSF63-0340												
PSF63-0390												
PSF63-0480												
PSF63-0580												
PSF63-0680												
PSF63-0770												
PSF63-0880												
PSF63-0960												
PSF63-1160												

65...192 A Types (Copper Bus Bars)

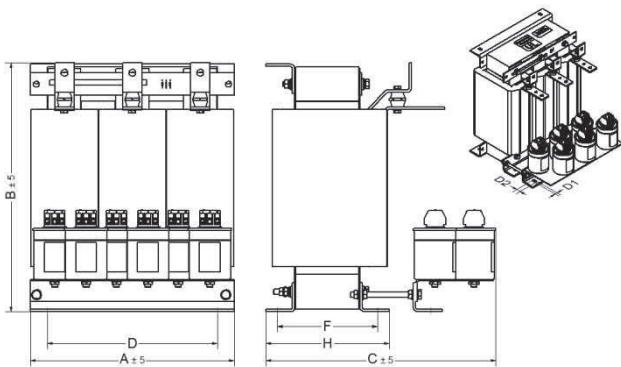

242...1160 A Types (Copper Bus Bars)

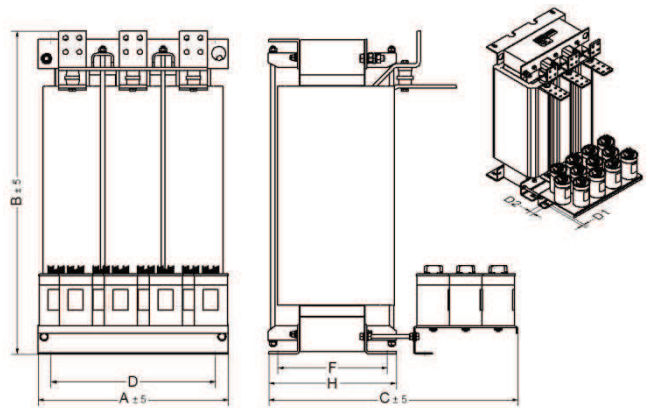

Bus Bar 20 mm

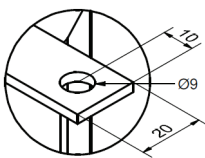

Bus Bar 30 mm

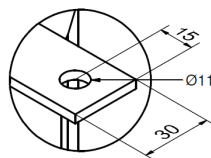

Bus Bar 40 mm

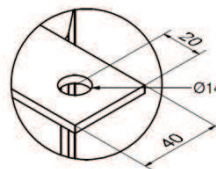

Bus Bar 50 mm

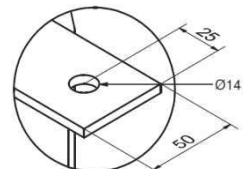

Bus Bar 60 mm

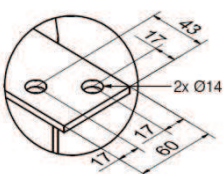

Bus Bar 80 mm

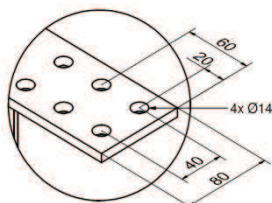

Connection Diagramm

