



INVERTER

Control terminal option

FR-A8TP

INSTRUCTION MANUAL

Vector control terminal block

PRE-OPERATION INSTRUCTIONS	1
INSTALLATION	2
WIRING	3
PARAMETER	4
ORIENTATION CONTROL	5
ENCODER FEEDBACK CONTROL	6
VECTOR CONTROL	7
ENCODER PULSE DIVIDING OUTPUT	8

Thank you for choosing this Mitsubishi inverter control terminal option.

This Instruction Manual provides handling information and precautions for use of the equipment. Incorrect handling might cause an unexpected fault. Before using this product, always read this Instruction Manual carefully to use this product correctly.

Please forward this Instruction Manual to the end user.

Safety instructions

Do not attempt to install, operate, maintain or inspect the product until you have read through this Instruction Manual and appended documents carefully and can use the equipment correctly. Do not use this product until you have a full knowledge of the equipment, safety information and instructions. In this Instruction Manual, the safety instruction levels are classified into "Warning" and "Caution".



Warning

Incorrect handling may cause hazardous conditions, resulting in death or severe injury.



Caution

Incorrect handling may cause hazardous conditions, resulting in medium or slight injury, or may cause only material damage.

The **Caution** level may even lead to a serious consequence according to conditions. Both instruction levels must be followed because these are important to personal safety.

◆ Electric Shock Prevention



Warning

- While the inverter power is ON, do not open the front cover or the wiring cover. Do not run the inverter with the front cover or the wiring cover removed. Otherwise you may access the exposed high voltage terminals or the charging part of the circuitry and get an electric shock.
- Do not remove the inverter front cover even if the power supply is disconnected. The only exception for this would be when performing wiring and periodic inspection. You may accidentally touch the charged inverter circuits and get an electric shock.
- Before wiring or inspection, LED indication of the inverter unit operation panel must be switched OFF. Any person who is involved in wiring or inspection shall wait for at least 10 minutes after the power supply has been switched OFF and check that there is no residual voltage using a tester or the like. For some time after the power-OFF, a high voltage remains in the smoothing capacitor, and it is dangerous.
- Any person who is involved in wiring or inspection of this equipment shall be fully competent to do the work.
- The control terminal option must be installed before wiring. Otherwise you may get an electric shock or be injured.
- Do not touch the control terminal option or handle the cables with wet hands. Otherwise you may get an electric shock.
- Do not subject the cables to scratches, excessive stress, heavy loads or pinching. Otherwise you may get an electric shock.

◆ Injury Prevention



Caution

- The voltage applied to each terminal must be the ones specified in the Instruction Manual. Otherwise a burst, damage, etc. may occur.
- The cables must be connected to the correct terminals. Otherwise a burst, damage, etc. may occur.
- The polarity (+ and -) must be correct. Otherwise a burst or damage may occur.
- While power is ON or for some time after power OFF, do not touch the inverter as it will be extremely hot. Touching these devices may cause a burn.

◆ Additional Instructions

The following instructions must be also followed. If the product is handled incorrectly, it may cause unexpected fault, an injury, or an electric shock.

Caution

Transportation and mounting

- Do not install or operate the control terminal option if it is damaged or has parts missing.
- Do not stand or rest heavy objects on the product.
- The mounting orientation must be correct.
- Foreign conductive objects must be prevented from entering the inverter. That includes screws and metal fragments or other flammable substance such as oil.
- If halogen-based materials (fluorine, chlorine, bromine, iodine, etc.) infiltrate into a Mitsubishi product, the product will be damaged. Halogen-based materials are often included in fumigant, which is used to sterilize or disinfest wooden packages. When packaging, prevent residual fumigant components from being infiltrated into Mitsubishi products, or use an alternative sterilization or disinfection method (heat disinfection, etc.) for packaging. Sterilization or disinfection of wooden package should also be performed before packing a product.

Test run

- Before starting operation, each parameter must be confirmed and adjusted. A failure to do so may cause some machines to make unexpected motions.

Warning

Usage

- Do not modify the equipment.
- Do not perform parts removal which is not instructed in this manual. Doing so may lead to fault or damage of the product.

Caution

Usage

- When parameter clear or all parameter clear is performed, the required parameters must be set again before starting operations. Because all parameters return to their initial values.
- Static electricity in your body must be discharged before you touch the product.

Maintenance, inspection and parts replacement

- Do not carry out a megger (insulation resistance) test.

Disposal

- The product must be treated as industrial waste.

General instruction

- Many of the diagrams and drawings in this Instruction Manual show the inverter without a cover or partially open for explanation. Never operate the inverter in this manner. The cover must be reinstalled and the instructions in the Instruction Manual must be followed when operating the inverter.

– CONTENTS –

1	PRE-OPERATION INSTRUCTIONS	7
1.1	Unpacking and product confirmation.....	7
1.1.1	Product confirmation	7
1.1.2	SERIAL number check.....	8
1.1.3	Component names.....	9
1.1.4	Terminal layout	10
1.1.5	Control logic switchover	11
1.1.6	Terminal OH control logic switchover.....	12
1.2	Terminal connection diagrams.....	13
1.3	Control terminal specification	14
2	INSTALLATION	23
2.1	Pre-installation instructions	23
2.2	Installation procedure	23
3	WIRING	25
3.1	Encoder specification / terminating resistor switch setting.....	25
3.2	Encoder	27
3.3	Wiring of control circuit	29
3.3.1	Wiring method.....	29
3.3.2	Wire treatment	31
3.3.3	Wiring of terminals related to the encoder	33
3.4	Encoder cables dedicated to Mitsubishi motors	34
4	PARAMETER	36
4.1	Extended parameter list.....	36
4.2	Thermal protector input	39
4.3	Encoder input selection	40

5	ORIENTATION CONTROL	42
5.1	Connection diagram	42
5.2	Terminals	44
5.3	Specifications	45
5.4	Parameter related to orientation control	46
5.4.1	Encoder orientation gear ratio setting	46
6	ENCODER FEEDBACK CONTROL	48
6.1	Connection diagram	48
6.2	Specifications	49
7	VECTOR CONTROL	50
7.1	Connection diagram	50
7.2	Specifications	54
8	ENCODER PULSE DIVIDING OUTPUT	55
8.1	Connection diagram	55
8.2	Parameter related to encoder pulse dividing output.....	57



1 PRE-OPERATION INSTRUCTIONS

1.1 Unpacking and product confirmation

Take the control terminal option out of the package, check the product name, and confirm that the product is as you ordered and intact.

The product is a control terminal option for the FR-A800 series.

1.1.1 Product confirmation

Check the enclosed items.

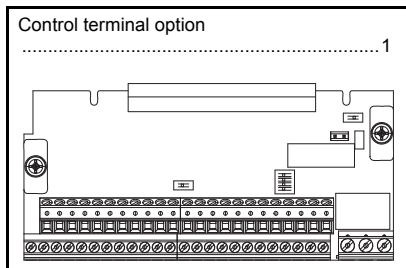

1.1.2 SERIAL number check

The FR-A8TP can be used for the inverter models listed below with the following SERIAL number or later. Check the SERIAL number indicated on the inverter rating plate or package. For the location of the rating plate, refer to the Instruction Manual (Detailed) of the inverter.

Rating plate example

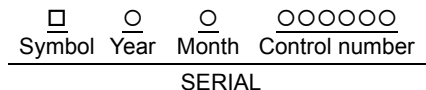
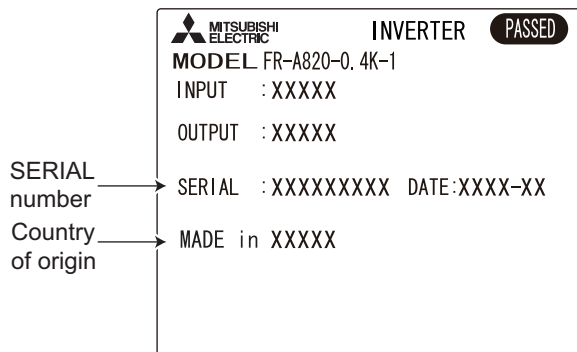

The SERIAL consists of one symbol, two characters indicating the production year and month, and six characters indicating the control number.

The last digit of the production year is indicated as the Year, and the Month is indicated by 1 to 9, X (October), Y (November), or Z (December).

- FR-A800 series

Model	Country of origin indication	SERIAL number
FR-A820-00046(0.4K) to 04750(90K) FR-A840-00023(0.4K) to 06830(280K) FR-A842-07700(315K) to 12120(500K) FR-A846-00023(0.4K) to 00470(18.5K)	MADE in Japan	□51○○○○○ or later
	MADE in China	□53○○○○○ or later

1.1.3 Component names

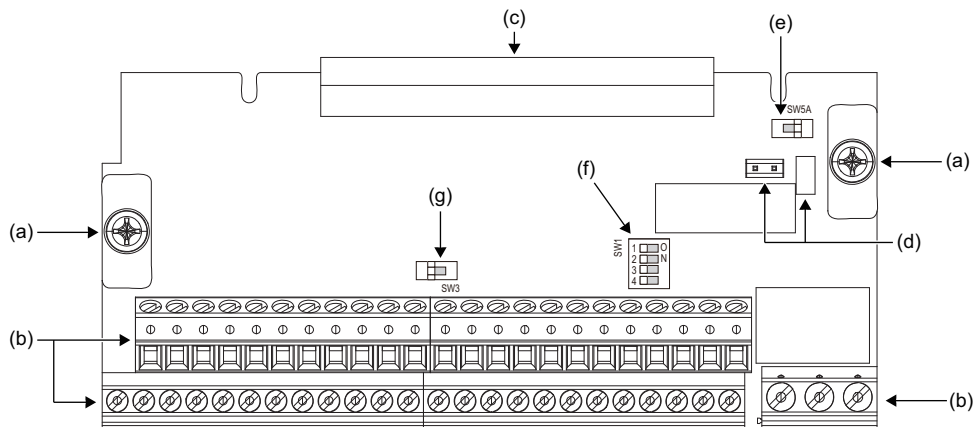

Symbol	Name	Description	Refer to page
a	Mounting screw	Fixes the option to the inverter.	23
b	Terminal block	Connect signal cables.	25
c	Connector	Connects to the control circuit connection connector of the inverter.	23
d	Control logic switchover jumper connector	Switches the control logic (sink logic/source logic).	11
e	External thermal relay switch (SW5A)	Switches the control logic of terminal OH (sink logic/source logic).	39
f	Terminating resistor selection switch (SW1)	Switches ON or OFF the internal terminating resistor.	25
g	Encoder type selection switch (SW3)	Switches the encoder type (differential line driver/complementary).	25

1.1.4 Terminal layout

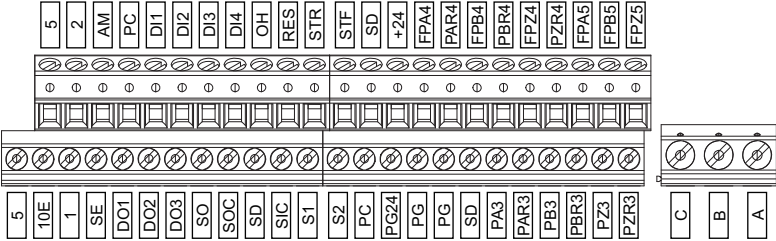

1.1.5 Control logic switchover

Switch the control logic of input signals as necessary.

To change the control logic, change the jumper connector position on the control circuit board.

Connect the jumper connector to the connector pin of the desired control logic using a pair of needle-nose pliers etc. The control logic of input signals is initially set to the sink logic (SINK).

For the details of the control logic, refer to the Instruction Manual of the inverter

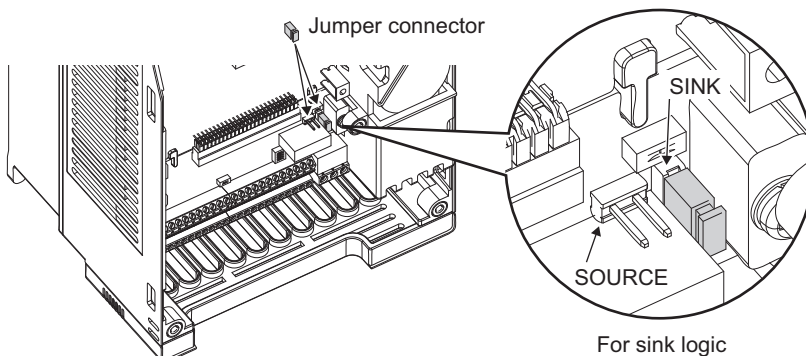

1.1.6 Terminal OH control logic switchover

Change the external thermal relay switch (SW5A) position to switch the terminal OH control logic (sink logic or source logic) as necessary. The control logic of input signals is initially set to the sink logic (SINK).

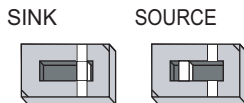

NOTE

- The terminal OH control logic cannot be switched by “1.1.5 Control logic switchover” on [page 11](#).

1.2 Terminal connection diagrams

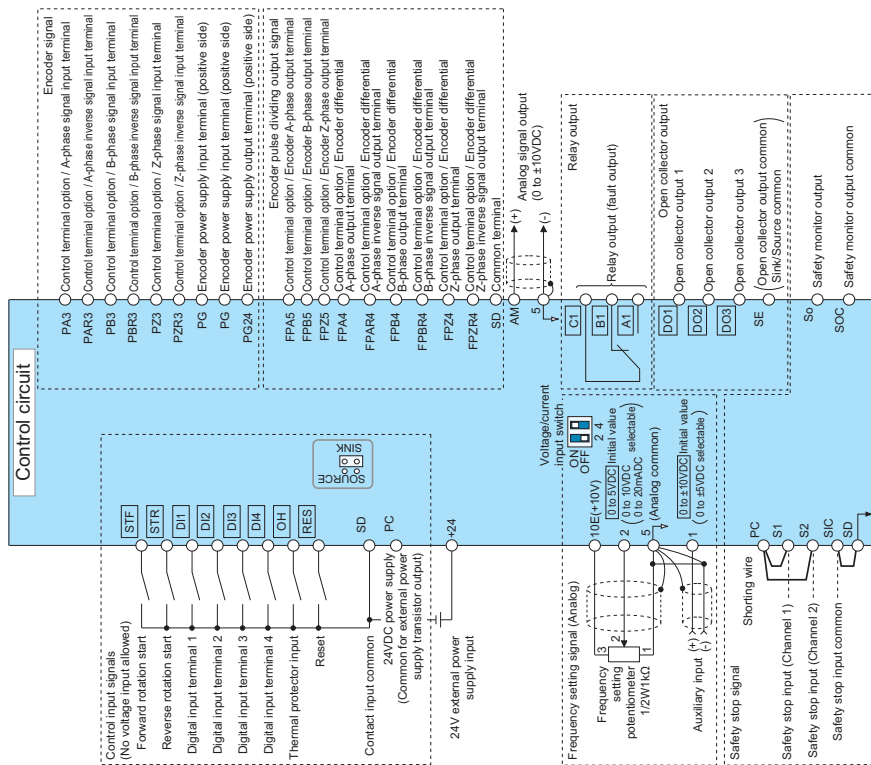

1.3 Control terminal specification

◆ Input signal

Function	Terminal symbol	Terminal name	Terminal function description		Rated specification
Contact input	STF	Forward rotation start	Turn ON the STF signal to start forward rotation and turn it OFF to stop.	When the STF and STR signals are turned ON simultaneously, the stop command is given.	Input resistance: 4.7 kΩ Voltage when contacts are open: 21 to 27 VDC Current when contacts are short-circuited: 4 to 6 mADC *When terminal DI4 is used as a pulse train input terminal: Input resistance: 2 kΩ When contacts are short-circuited: 8 to 13 mADC
	STR	Reverse rotation start	Turn ON the STR signal to start reverse rotation and turn it OFF to stop.		
	DI1 to DI4	Digital input terminal 1 to 4	Functions can be assigned to terminals by the input terminal function selection (Pr.180 to Pr.182, Pr.185).		
	OH	Thermal protector input	Temperature detector input terminal for overheat protection of a motor. When the OH signal turns OFF, the external thermal relay (E.OHT) protective function is activated Use Pr.876 to switch valid/invalid status of terminal function. Switches the control logic (sink logic or source logic) independently by the external thermal relay switch (SW5A).		
	RES	Reset	Use this signal to reset a fault output provided when a protective function is activated. Turn ON the RES signal for 0.1 s or longer, then turn it OFF. In the initial setting, reset is always enabled. By setting Pr.75 , reset can be enabled only at an inverter fault occurrence. The inverter recovers about 1 s after the reset is released.		

Function	Terminal symbol	Terminal name	Terminal function description	Rated specification
Contact input	SD	Contact input common (sink)	Common terminal for the contact input terminal (sink logic).	—
		External transistor common (source)	Connect this terminal to the power supply common terminal of a transistor output (open collector output) device, such as a programmable controller, in the source logic to avoid malfunction by undesirable current.	
		24 VDC power supply common	Common terminal for the 24 VDC power supply (terminal PC, terminal +24). Isolated from terminals 5 and SE.	
		Encoder pulse dividing output common	Common terminal for the encoder pulse dividing output terminal.	
		24 V encoder power supply common	Common terminal for the 24 V encoder power supply terminal (terminal PG24).	
	PC	External transistor common (sink)	Connect this terminal to the power supply common terminal of a transistor output (open collector output) device, such as a programmable controller, in the source logic to avoid malfunction by undesirable current.	Power supply voltage range: 19.2 to 28.8 VDC Permissible load current: 100 mA
		Contact input common (source)	Common terminal for contact input terminal (source logic).	
		24 VDC power supply	Can be used as a 24 VDC 0.1 A power supply.	

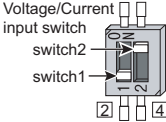
Function	Terminal symbol	Terminal name	Terminal function description	Rated specification
Frequency setting	10E	Frequency setting power supply	Change the input specification of the terminal 2 using Pr.73 when connecting it to the terminal 10E.	10 VDC ± 0.4 V Permissible load current: 10 mA
	2	Frequency setting (voltage)	Inputting 0 to 5 VDC (or 0 to 10 V, 0 to 20 mA) provides the maximum output frequency at 5 V (10 V, 20 mA) and makes input and output proportional. Use Pr.73 to switch among input 0 to 5 VDC (initial setting), 0 to 10 VDC, and 0 to 20 mA. Set the voltage/current input switch in the ON position to select current input (0 to 20 mA).*1	When voltage is input: Input resistance: 10 k Ω ± 1 k Ω Maximum permissible voltage: 20 VDC When current is input: Input resistance: 245 Ω ± 5 Ω Permissible maximum current: 30 mA 
	1	Frequency setting auxiliary	Inputting 0 to ± 5 VDC or 0 to ± 10 VDC adds this signal to terminal 2 frequency setting signal. Use Pr.73 to switch between input 0 to ± 5 VDC and 0 to ± 10 VDC (initial setting). Use Pr.868 to switch terminal functions.	Input resistance: 10 k Ω ± 1 k Ω Permissible maximum: voltage ± 20 VDC
	5	Frequency setting common Analog signal output common	Common terminal for frequency setting signal (terminal 2 or 1) and analog output terminal AM. Do not earth (ground).	—

Function	Terminal symbol	Terminal name	Terminal function description	Rated specification
Encoder signal	PA3	Control terminal option / A-phase signal input terminal	A-, B- and Z-phase signals are input from the encoder.	Differential line driver/ Complementary
	PAR3	Control terminal option / A-phase inverse signal input terminal		Differential line driver
	PB3	Control terminal option / B-phase signal input terminal		Differential line driver/ Complementary
	PBR3	Control terminal option / B-phase inverse signal input terminal		Differential line driver
	PZ3	Control terminal option / Z-phase signal input terminal		Differential line driver/ Complementary
	PZR3	Control terminal option / Z-phase inverse signal input terminal		Differential line driver
	PG	Encoder power supply terminal (positive side)	Input power for the encoder power supply. Connect the external power supply (5 V, 12 V, 15 V) and the encoder power cable. When the encoder output is the differential line driver type, only 5 V can be input. Make sure the voltage of the external power supply the same as the encoder output voltage. (Check the encoder specification.) If using the 24 V power supply of the FR-A8TP, 24 V power can be supplied from terminal PG24.	—

Function	Terminal symbol	Terminal name	Terminal function description	Rated specification
External power supply input	+24	24 V external power supply input	For connecting a 24 V external power supply. If a 24 V external power supply is connected, power is supplied to the control circuit while the main power circuit is OFF.	Input voltage: 23 to 25.5 VDC Input current: 1.4 A or less

*1 Set **Pr.73**, **Pr.267**, and the voltage/current input switch correctly, then input an analog signal in accordance with the setting. (Refer to the Instruction Manual (Detailed) of the inverter.)

Applying a voltage with the voltage/current input switch ON (current input is selected) or a current with the switch OFF (voltage input is selected) could cause component damage of the inverter or analog circuits of output devices.

◆ Output signal

Type	Terminal symbol	Terminal name	Terminal function description	Rated specification
Relay	A, B, C	Relay output (fault output)	1 changeover contact output that indicates that an inverter's protective function has been activated and the outputs are stopped. Fault: discontinuity across B and C (continuity across A and C), Normal: continuity across Band C (discontinuity across A and C) The function of terminals can be changed with the output terminal function selection (Pr.195).	Contact capacity: 230 VAC 0.3 A (power factor = 0.4) 30 VDC 0.3 A

Type	Terminal symbol	Terminal name	Terminal function description	Rated specification
Open collector	DO1 to DO3	Digital output terminal 1 to 3	The function can be assigned to an output terminal by the output terminal function selection (Pr.190 to Pr.192).	Open collector output Permissible load: 24 to 27 VDC, 0.1 A
	SE	Open collector output common	Common terminal for terminals DO1, DO2, DO3. Isolated from terminals SD and 5.	—
Analog	AM	Analog voltage output	Outputs a selected monitored item (such as output frequency) among several monitored items according to the Pr.158 setting. The signal is not output during an inverter reset. The output signal is proportional to the magnitude of the corresponding monitoring item. Use Pr.55, Pr.56, and Pr.866 to set full scales for the monitored output frequency, output current, and torque.	Output signal: 0 to ± 10 VDC Permissible load current: 1 mA (load impedance: 10 k Ω or more) Resolution: 8 bits
Encoder pulse dividing output	FPA5	Control terminal option / Encoder A-phase output terminal	Outputs A-, B- and Z-phase (home position and mark pulse) signals from the encoder. The A- and B-phase signals can be divided by the ratio (1/n) and output. n=1 to 32767 (an integer) Use Pr.863 Encoder pulse division ratio for division. Common terminal is terminal SD.	Open collector output Permissible load: 24 to 27 VDC, maximum 50 mA
	FPB5	Control terminal option / Encoder B-phase output terminal		
	FPZ5	Control terminal option / Encoder Z-phase output terminal		

Type	Terminal symbol	Terminal name	Terminal function description	Rated specification
Encoder pulse dividing output	FPA4	Control terminal option / Encoder differential A-phase output terminal	Outputs A-, B- and Z-phase (home position and mark pulse) signals from the encoder. The A- and B-phase signals can be divided by the ratio (1/n) and output. n=1 to 32767 (an integer) Use Pr.863 Encoder pulse division ratio for division.	Differential line driver output Permissible load: 0.1 A
	FPAR4	Control terminal option / Encoder differential A-phase inverse signal output terminal		
	FPB4	Control terminal option / Encoder differential B-phase output terminal		
	FPBR4	Control terminal option / Encoder differential B-phase inverse signal output terminal		
	FPZ4	Control terminal option / Encoder differential Z-phase output terminal		
	FPZR4	Control terminal option / Encoder differential Z-phase inverse signal output terminal		
Power supply output for encoder	PG24	Encoder power supply terminal (positive side)	Used for the 24 VDC power supply for an encoder. If used, connect this terminal to terminal PG, and this will supply power from the terminal PG to the encoder.	24 to 26.4 VDC 80 mA

◆ Safety stop signal

Terminal symbol	Terminal name	Terminal function description	Rated specification
S1	Safety stop input (Channel 1)	The terminals S1 and S2 are used for the safety stop input signal for the safety relay module. The terminals S1 and S2 are used at the same time (dual channel). Inverter output is shutdown by shortening/opening between terminal S1 and SIC, or between S2 and SIC. In the initial status, terminal S1 and S2 are shorted with the terminal PC by shorting wires. The terminal SIC is shorted with the terminal SD. Remove the shorting wires and connect the safety relay module when using the safety stop function.	Input resistance: 4.7 kΩ Input current: 4 to 6 mADC (with 24 VDC input)
S2	Safety stop input (Channel 2)		
SIC	Safety stop input terminal common	Common terminal for terminals S1 and S2.	—
SO	Safety monitor output (open collector output)	Indicates the safety stop input signal status. Switched to LOW when the status is other than the internal safety circuit failure. Switched to HIGH during the internal safety circuit failure status. (LOW is when the open collector output transistor is ON (conducted). HIGH is when the transistor is OFF (not conducted).) Refer to the Safety stop function instruction manual (BCN-A23228-001) when the signal is switched to HIGH while both terminals S1 and S2 are open. (Please contact your sales representative for the manual.)	Permissible load: 24 VDC (27 VDC at maximum), 0.1 A (The voltage drop is 3.4 V at maximum while the signal is ON.)
SOC	Safety monitor output terminal common	Common terminal for terminal SO.	—

 **NOTE**

- The parameter names for function assignment to the terminals listed below or the terminal names for I/O terminal monitor (**Pr.52**) are the standard control circuit terminal names of the inverter.

FR-A8TP terminal name	Pr.		I/O terminal monitor
DI1	180	RL terminal function selection	RL
DI2	181	RM terminal function selection	RM
DI3	182	RH terminal function selection	RH
DI4	185	JOG terminal function selection	JOG
OH	—	—	AU
DO1	190	RUN terminal function selection	RUN
DO2	191	SU terminal function selection	SU
DO3	192	IPF terminal function selection	IPF
ABC	195	ABC1 terminal function selection	ABC1

For the details of the parameter setting or the I/O terminal monitor, refer to the Instruction Manual (Detailed) of the inverter.

- Same terminal has same specification between the terminal or the FR-A8TP and the standard control circuit terminal of the inverter.
Use **Pr.178**, **Pr.179**, **Pr.189**, or **Pr.158** to change the function of terminal STF, STR, RES, or AM respectively, same as the standard control circuit terminal of the inverter.
- Even when the FR-A8TP is installed in the inverter, the following standard control circuit I/O terminals of the inverter can be used only via communication (the RS-485 communication or other communication options) as if the standard control circuit is installed in the inverter.

Input terminal	RT, AU, STP, CS
Output terminal	OL, FU, ABC2

2 INSTALLATION

2.1 Pre-installation instructions

Check that the inverter's input power and the control circuit power are both OFF.

Caution

- Do not mount or remove the control terminal option while the input power is ON. Doing so may damage the inverter or the control terminal option.
- To avoid damage due to static electricity, static electricity in your body must be discharged before you touch the product.

2.2 Installation procedure

- (1) Loosen the two mounting screws at the both side of the standard control circuit terminal block. (These screws cannot be removed.)
Slide down the control circuit terminal block to remove it.

Loosen the screws

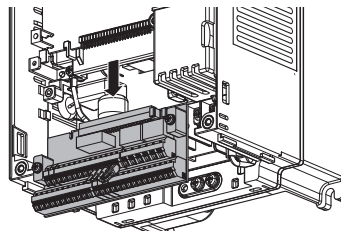
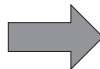
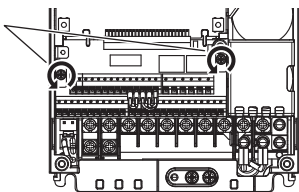

- (2) Be careful not to bend the pins of the inverter's control circuit connector, install the control terminal option and fix it with the mounting screws for the control terminal option. (Tightening torque: 0.33 to 0.4 N•m)

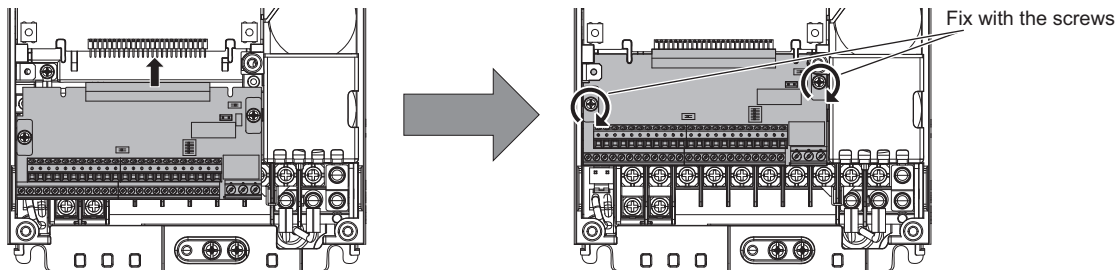

NOTE

The inverter will recognize the control terminal option at next power-ON.

3 WIRING

3.1 Encoder specification / terminating resistor switch setting

◆ Encoder specification selection switch (SW3)

Selects either differential line driver or complementary.

It is initially set to the complementary. Switch its position according to the output circuit.

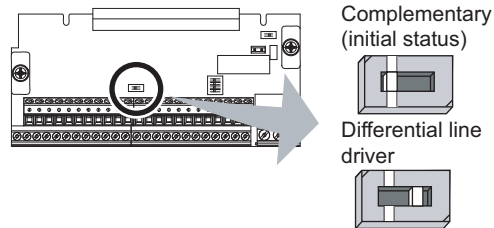

◆ Terminating resistor selection switch (SW1)

Selects "ON"/"OFF" of the internal terminating resistor.

Set the switch to "OFF (initial status)" when an encoder output type is complementary and set to "ON" when differential line driver.

ON: with internal terminating resistor

OFF: without internal terminating resistor (initial status)

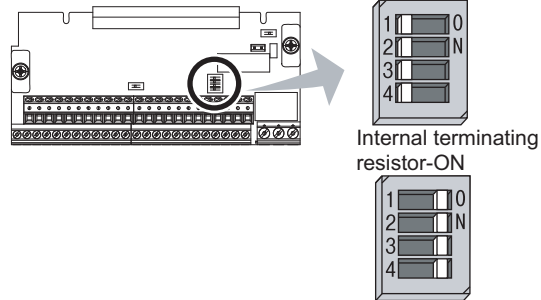

NOTE

- Set all switches to the same setting ("ON"/"OFF").
- Set the switch "OFF" when sharing an encoder with another unit (NC (computerized numerical controller), etc.) having a terminating resistor under the differential line driver setting.

◆ Motor used and switch setting

Motor		Encoder specification selection switch (SW3)	Terminating resistor selection switch (SW1)	Power supply specification*2
Mitsubishi standard motor with encoder Mitsubishi high-efficiency motor with encoder	SF-JR	Differential	ON	5 V
	SF-HR	Differential	ON	5 V
	Others	*1	*1	*1*3
Mitsubishi constant-torque motor with encoder	SF-JRCA	Differential	ON	5 V
	SF-HRCA	Differential	ON	5 V
	Others	*1	*1	*1*3
Vector control dedicated motor	SF-V5RU	Complementary	OFF	12 V, 24 V
Other manufacturer's motor with encoder		*1	*1	*1*3

*1 Set according to the motor (encoder) to be used.

*2 Prepare an encoder's power supply (5 V/12 V/15 V) according to the encoder to be used. Use terminal PG24 for the 24 V encoder's power supply.

*3 When the encoder output is the differential line driver type, only 5 V can be input.

3.2 Encoder

◆ Position detector (pulse encoder)

Output pulse specifications

Differential line driver

A/ \bar{A} signal 1000 P/R to 4096 P/R

B/ \bar{B} signal 1000 P/R to 4096 P/R

Z/ \bar{Z} signal 1 P/R

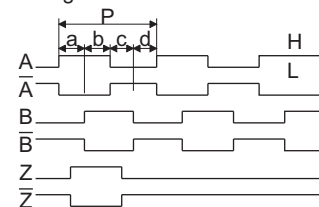

Complementary

A signal 1000 P/R to 4096 P/R

B signal 1000 P/R to 4096 P/R

Z signal 1 P/R

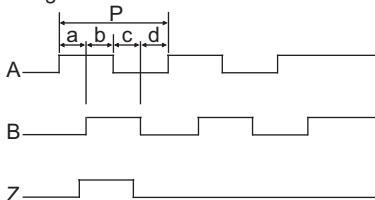

Position detector
Encoder



· When rotation is counterclockwise as viewed from the shaft end (A) of the encoder.

· a, b, c, d should be $1/4 \pm 1/8$ pulses.

NOTE

- The encoder can be shared under orientation control, encoder feedback control or vector control. Use an encoder which has a pulse count of 1000 to 4096 ppr (pulse per revolution).
- Couple the encoder with the motor shaft or with the shaft that stops the main shaft at the specified position. Couple it with the speed ratio of 1:1 and without any mechanical looseness.
- To ensure correct operation, the encoder must be set in the proper rotation direction, and the A and B phases must be connected correctly.

◆ Power supply

Prepare an encoder's power supply (5 V, 12 V, 15 V, etc.) according to the encoder to be used. Make the voltage of the external power supply same as the encoder output voltage. (Check the encoder specification.) Use terminal PG24 for the 24 V encoder's power supply.

The encoder's power supply is shared under orientation control, encoder feedback control or vector control.

- Specifications of the encoders equipped in the motors with encoders and the vector-control dedicated motors

Item	Encoder for SF-JR/HR/JRCA/HRCA	Encoder for SF-V5RU
Resolution	1024 pulses/rev	2048 pulses/rev
Power supply voltage	5 VDC $\pm 10\%$	12 VDC $\pm 10\%$, 24 VDC $\pm 10\%$
Current consumption	150 mA or less	
Output signal form	A, B phases (90° phase shift) Z phase: 1 pulse/rev	
Output circuit	Equivalent or the differential line driver 74LS113	Complementary
Output voltage	H level: 2.4 V or more L level: 0.5 V or less	H level: (Power supply for encoder-3 V) or more L level: 3 V or less



- When the input power supply voltage to the encoder and its output voltage differ, the protective function (E.ECT) may be activated.

3.3 Wiring of control circuit

3.3.1 Wiring method

- (1) Refer to [page 31](#) and treat the wires.
- (2) Loosen the terminal screw and insert the cable into the terminal.
- (3) Tighten the screw according to the specified tightening torque.
Undertightening may cause cable disconnection or malfunction. Overtightening may cause a short circuit or malfunction due to damage to the screw or unit.
Tightening torque: 0.5 N•m to 0.6 N•m (terminals A, B, and C)
0.22 N•m to 0.25 N•m (terminals other than described above)
Small flat-blade screwdriver (Tip thickness: 0.4 mm / tip width: 2.5 mm)

NOTE

- For the connection to the terminal 5, use a screwdriver with a diameter of 1.6 mm or less. Put the screwdriver to avoid contact with the mounting screw area.

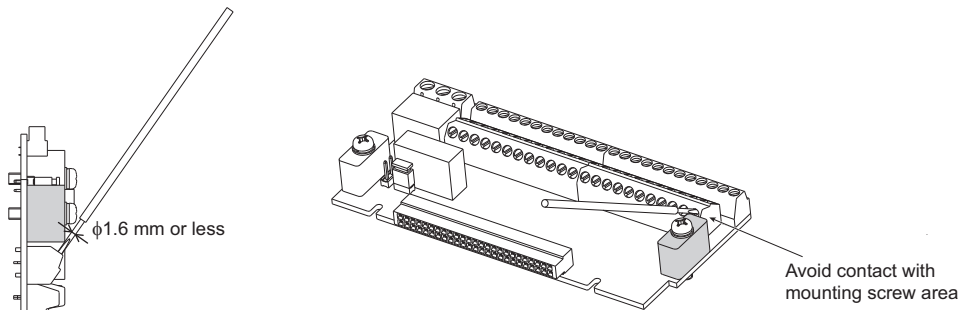

- When one position detector is shared between the FR-A8TP and the CNC (computerized numerical controller), its output signal should be connected as shown below. In this case, the wiring length between the FR-A8AP and the CNC should be as short as possible, within 5 m.

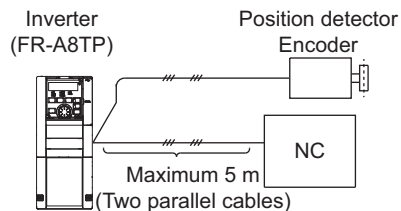

3.3.2 Wire treatment

- For the control circuit wiring except for terminals related to the encoder, strip off the sheath of a cable and use as it is.
- Untwist the shielded twisted pair cables after stripping its sheath.
Also, treat the shielding wires of the shielded twisted pair cable to ensure that they will not contact conductive areas.

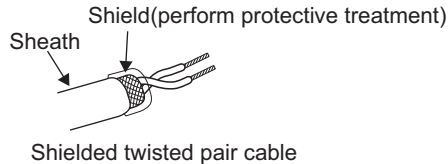

- Strip off the sheath for the below length. If the length of the sheath peeled is too long, a short circuit may occur with neighboring wires. If the length is too short, wires might come off.
Wire the stripped cable after twisting it to prevent it from becoming loose. In addition, do not solder it.
Use a blade terminal as necessary.

Cable stripping length

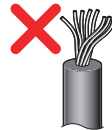
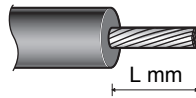

Terminal name	L (mm)
A, B, C	6
other than the above	5

Recommended cable gauge: 0.75 mm²

NOTE

Blade terminals commercially available (as of February 2012. The product may be changed without notice.)

- Phoenix Contact Co., Ltd.

Terminal screw size	Cable gauge (mm ²)	Ferrule terminal model		Crimping tool name
		With insulation sleeve	Without insulation sleeve	
M3 (Terminals A, B, C)	0.75	AI 0,75-6GY	A 0,75-6	CRIMPFOX 6
M2 (Terminals other than the above)	0.3, 0.5	AI 0,5-6WH	A 0,5-6	

- NICHIFU Co.,Ltd.

Terminal screw size	Cable gauge (mm ²)	Blade terminal model	Insulation product number	Crimping tool product number
M3 (Terminals A, B, C) M2 (Terminals other than the above)	0.3 to 0.75	BT 0.75-7	VC 0.75	NH 69

- When using a blade terminal (without insulation sleeve), take caution that the twisted wires do not come out.

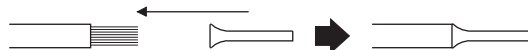

3.3.3 Wiring of terminals related to the encoder

Use shielded twisted pair cables (0.2 mm² or larger) for connection the encoder. For the wiring to the terminals PG and SD, use several cables in parallel or use a thick cable, according to the wiring length. To protect the cables from noise, run them away from any source of noise (e.g. the main circuit and power voltage).

Wiring length	Parallel connection (Cable gauge 0.2 mm ²)	Larger-size cable
Within 10 m	At least two cables in parallel	0.4 mm ² or larger
Within 20 m	At least four cables in parallel	0.75 mm ² or larger
Within 100 m *1	At least six cables in parallel	1.25 mm ² or larger

- *1 When differential line driver is set and a wiring length is 30 m or more. The wiring length can be extended to 100 m by increasing the 5 V power supply (approximately to 5.5 V) while using six or more 0.2 mm² gauge cables in parallel or a 1.25 mm² or larger gauge cable. The voltage applied must be within power supply specifications of encoder.

To reduce noise of the encoder cable, earth (ground) the encoder's shielded cable to the enclosure (as close as possible to the inverter) with a metal P-clip or U-clip.

Example of parallel connection with two cables (with complementary encoder output)

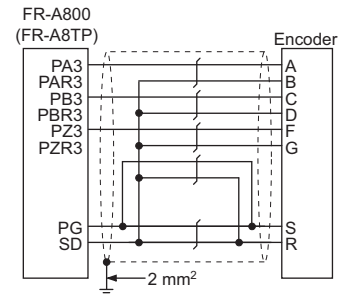

Earthing (grounding) example using a P-clip

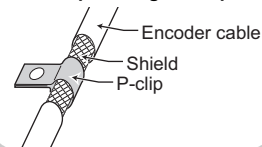

NOTE

- For details of the optional encoder dedicated cable (FR-JCBL/FR-V7CBL), refer to [page 34](#).
- The FR-V7CBL is provided with a P-clip for earthing (grounding) shielded cables.

3.4 Encoder cables dedicated to Mitsubishi motors

Use dedicated encoder cables to connect with Mitsubishi encoder-equipped motors.

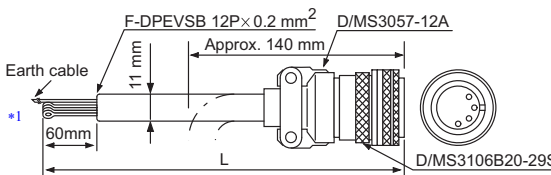
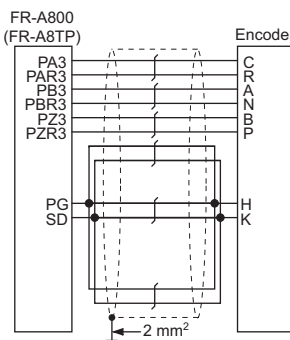
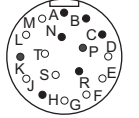
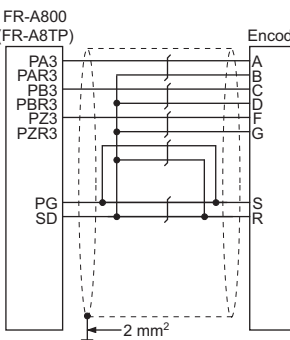
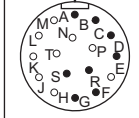
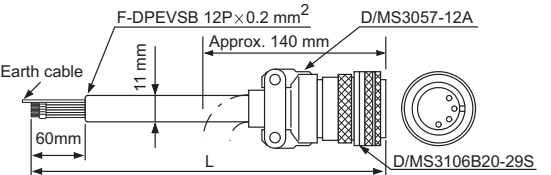
FR-JCBL	FR-V7CBL																
<p>For SF-JR/HR/JRCA/HRCA (with encoder)</p>  <p style="text-align: right;">D/MS3106B20-29S</p> <table border="1" style="margin-left: auto; margin-right: auto;"> <thead> <tr style="background-color: #00FFFF;"> <th>Type</th> <th>Length L (m)</th> </tr> </thead> <tbody> <tr> <td>FR-JCBL5</td> <td>5</td> </tr> <tr> <td>FR-JCBL15</td> <td>15</td> </tr> <tr> <td>FR-JCBL30</td> <td>30</td> </tr> </tbody> </table> <div style="display: flex; justify-content: space-around; align-items: flex-start;"> <div style="text-align: center;">  <p>FR-A800 (FR-A8TP)</p> <p>Encoder</p> <p>Positioning keyway</p>  <p>D/MS3106B20-29S (As viewed from wiring side)</p> </div> <div style="text-align: center;">  <p>FR-A800 (FR-A8TP)</p> <p>Encoder</p> <p>Positioning keyway</p>  <p>D/MS3106B20-29S (As viewed from wiring side)</p> </div> </div>	Type	Length L (m)	FR-JCBL5	5	FR-JCBL15	15	FR-JCBL30	30	<p>For SF-V5RU and SF-THY</p>  <p style="text-align: right;">D/MS3106B20-29S</p> <ul style="list-style-type: none"> • A P-clip for earthing (grounding) a shielded cable is provided. <table border="1" style="margin-left: auto; margin-right: auto;"> <thead> <tr style="background-color: #00FFFF;"> <th>Type</th> <th>Length L (m)</th> </tr> </thead> <tbody> <tr> <td>FR-V7CBL5</td> <td>5</td> </tr> <tr> <td>FR-V7CBL15</td> <td>15</td> </tr> <tr> <td>FR-V7CBL30</td> <td>30</td> </tr> </tbody> </table>	Type	Length L (m)	FR-V7CBL5	5	FR-V7CBL15	15	FR-V7CBL30	30
Type	Length L (m)																
FR-JCBL5	5																
FR-JCBL15	15																
FR-JCBL30	30																
Type	Length L (m)																
FR-V7CBL5	5																
FR-V7CBL15	15																
FR-V7CBL30	30																

*1 As the terminal block of the FR-A8TP is an insertion type, earth (ground) cables need to be modified. (Refer to [page 31](#).)

◆ **Connection terminal compatibility table**

Motor		SF-JR/HR/JRCA/HRCA (with encoder)	SF-V5RU, SF-THY
Encoder cable		FR-JCBL	FR-V7CBL
FR-A8TP terminal	PA3	PA	PA
	PAR3	PAR	Keep this open.
	PB3	PB	PB
	PBR3	PBR	Keep this open.
	PZ3	PZ	PZ
	PZR3	PZR	Keep this open.
	PG	5E	PG
	SD	AG2	SD

4.1 Extended parameter list

When the FR-A8TP is installed in the inverter, the following parameters are extended.

Pr.	Pr. group	Name	Setting range	Minimum setting increments	Initial value	Refer to page
350	A510	Stop position command selection	0, 1, 9999	1	9999	*1
351	A526	Orientation speed	0 to 30 Hz	0.01 Hz	2 Hz	*1
352	A527	Creep speed	0 to 10 Hz	0.01 Hz	0.5 Hz	*1
353	A528	Creep switchover position	0 to 16383	1	511	*1
354	A529	Position loop switchover position	0 to 8191	1	96	*1
355	A530	DC injection brake start position	0 to 255	1	5	*1
356	A531	Internal stop position command	0 to 16383	1	0	*1
357	A532	Orientation in-position zone	0 to 255	1	5	*1
358	A533	Servo torque selection	0 to 13	1	1	*1
360	A511	16-bit data selection	0 to 127	1	0	*1
361	A512	Position shift	0 to 16383	1	0	*1
362	A520	Orientation position loop gain	0.1 to 100	0.1	1.0	*1
363	A521	Completion signal output delay time	0 to 5 s	0.1 s	0.5 s	*1
364	A522	Encoder stop check time	0 to 5 s	0.1 s	0.5 s	*1
365	A523	Orientation limit	0 to 60 s, 9999	1 s	9999	*1

Pr.	Pr. group	Name	Setting range	Minimum setting increments	Initial value	Refer to page
366	A524	Recheck time	0 to 5 s, 9999	0.1 s	9999	*1
367	G240	Speed feedback range	0 to 590 Hz, 9999	0.01 Hz	9999	*1
368	G241	Feedback gain	0 to 100	0.1	1	*1
393	A525	Orientation selection	0 to 2, 10 to 12	1	0	*1
394	A540	Number of machine side gear teeth	0 to 32767	1	1	46
395	A541	Number of motor side gear teeth	0 to 32767	1	1	46
396	A542	Orientation speed gain (P term)	0 to 1000	1	60	*1
397	A543	Orientation speed integral time	0 to 20 s	0.001 s	0.333 s	*1
398	A544	Orientation speed gain (D term)	0 to 100	0.1	1	*1
399	A545	Orientation deceleration ratio	0 to 1000	1	20	*1
635	M610	Cumulative pulse clear signal selection	0, 1, 2, 3	1	0	*1
636	M611	Cumulative pulse division scaling factor	1 to 16384	1	1	*1
637	M612	Control terminal option-Cumulative pulse division scaling factor	1 to 16384	1	1	*1
638	M613	Cumulative pulse storage	0, 1, 2, 3	1	0	*1
823	G215	Speed detection filter 1	0 to 0.1 s	0.001 s	0.001 s	*1
833	G315	Speed detection filter 2	0 to 0.1 s, 9999	0.001 s	9999	*1
851	C240	Control terminal option-Number of encoder pulses	0 to 4096	1	2048	40
852	C241	Control terminal option-Encoder rotation direction	0, 1, 100, 101	1	1	40
853	H417	Speed deviation time	0 to 100 s	0.1 s	1 s	*1

Pr.	Pr. group	Name	Setting range	Minimum setting increments	Initial value	Refer to page
855	C248	Control terminal option-Signal loss detection	0, 1	1	0	40
862	C242	Encoder option selection	0, 1	1	0	40
863	M600	Control terminal option-Encoder pulse division ratio	1 to 32767	1	1	57
873	H415	Speed limit	0 to 400 Hz	0.01 Hz	20 Hz	*1
876	H022	Thermal protector input	0, 1	1	1	39

*1 Refer to the Instruction Manual (Detailed) of the inverter.

4.2 Thermal protector input

Pr.	Pr. group	Name	Initial value	Setting range	Description
876	H022	Thermal protector input	1	0	Terminal OH is invalid.
				1	Terminal OH is valid.

- When the motor with a temperature detector for overheat protection is used, use terminal OH to input contact signals of the thermal relay, etc. for overheat protection of a motor.
- Use **Pr.876** to set valid/invalid status of terminal OH function when the FR-A8TP is installed.
- When terminal OH is valid and the OH signal turns OFF, the protective function (E.OHT) is activated.
- Set "7" in any of **Pr.180 to Pr.182, or Pr.185 (input terminal function selection)** to assign the OH signal to another terminal.

NOTE

- Change the external thermal relay switch (SW5A) position to switch the terminal OH control logic (sink logic or source logic) as necessary.
Sink: When the connection between terminals OH and SD is open, E.OHT is activated.
Source: When the connection between terminals OH and PC is open, E.OHT is activated.
- Terminal OH is always for the OH signal. Any other signals cannot be assigned to terminal OH.

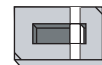

SINK

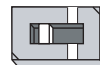

SOURCE



4.3 Encoder input selection

Pr.	Pr. group	Name	Initial value	Setting range	Description	
851	C240	Control terminal option-Number of encoder pulses	2048	0 to 4096	Set the number of pulses output from the encoder connected to the FR-A8TP. Set the number of pulses before it is multiplied by 4.	
852	C241	Control terminal option-Encoder rotation direction	1	0	Set when using a motor (encoder) for which forward rotation is clockwise (CW) viewed from the shaft 	Set for the operation at 120 Hz or less.
				100		Set for the operation at a frequency higher than 120 Hz.
				1	Set when using a motor (encoder) for which forward rotation is counterclockwise (CCW) viewed from the shaft 	Set for the operation at 120 Hz or less.
				101		Set for the operation at a frequency higher than 120 Hz.
855	C248	Control terminal option-Signal loss detection	0	0	Signal loss detection disabled	
				1	Signal loss detection enabled	
862	C242	Encoder option selection	0	0	First motor: FR-A8AP, Second motor: FR-A8TP	
				1	First motor: FR-A8TP, Second motor: FR-A8AP	



NOTE

- If operating at a frequency higher than 120 Hz with **Pr.852** = "0 or 1", the motor rotation will be unstable.

- Using the FR-A8TP together with the plug-in option FR-A8AP enables vector control or machine end orientation control by switching between two encoder-equipped motors. Use **Pr.862** to set the combination of the motors (first/second) and the options (FR-A8TP/FR-A8AP).

Pr.862 Encoder option selection	Pr.393 Orientation selection	RT=OFF (First motor)	RT=ON (Second motor)*1	Machine end orientation control
0 (initial value)	0, 1, 2	FR-A8AP	FR-A8TP	Disabled
	10, 11, 12			
1	0, 1, 2	FR-A8TP	FR-A8AP	Enabled
	10, 11, 12	Motor end: FR-A8TP Machine end: FR-A8AP	—	

*1 When **Pr.450 Second applied motor** = "9999", the first motor is selected even if the RT signal turns ON.

- Use the following parameters for the encoder input setting. The encoder input setting can be made regardless of the **Pr.862** setting and first/second motor setting.

Parameter name	Parameter for control terminal option (FR-A8TP)	Parameter for plug-in option (FR-A8AP)
Encoder rotation direction	852	359
Number of encoder pulses	851	369
Encoder signal loss detection enable/disable selection	855	376

- To input the RT signal, set "3" in any of **Pr.178 to Pr.182, Pr.185, or Pr.189 (input terminal function selection)** to assign the function to a terminal.

5 ORIENTATION CONTROL

The inverter can adjust the stop position (Orientation control) using a position detector (encoder) attached to a place such as the main shaft of the machine.

For the details of the parameters used for orientation control, refer to the Instruction Manual (Detailed) of the inverter.

5.1 Connection diagram

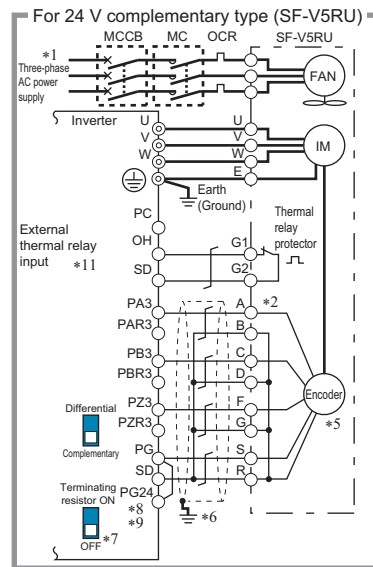
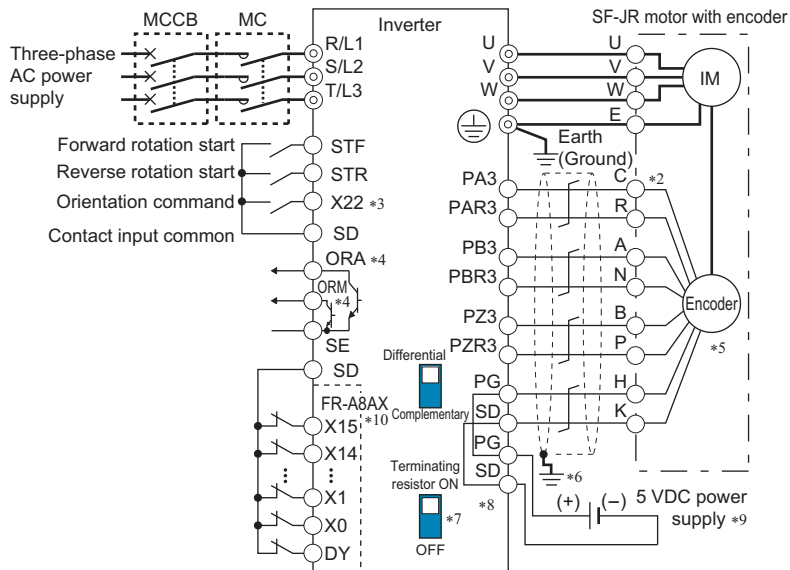

- *1 The power supply of the fan for a 7.5 kW or lower dedicated motor is single phase. (200 V/50 Hz, 200 to 230 V/60 Hz)
- *2 The pin number differs according to the encoder used.
- *3 Use **Pr.178 to Pr.182, Pr.185, or Pr.189 (input terminal function selection)** to assign the function to a terminal.
For the details, refer to the Instruction Manual (Detailed) of the inverter.
- *4 Use **Pr.190 to Pr.192, or Pr.195 (output terminal function selection)** to assign the function to a terminal.
For the details, refer to the Instruction Manual (Detailed) of the inverter.
- *5 Connect the encoder so that there is no looseness between the motor and motor shaft. Speed ratio must be 1:1.
- *6 Earth (ground) the shield of the encoder cable to the enclosure using a tool such as a P-clip. (**Refer to page 29.**)
- *7 For the differential line driver, set the terminating resistor selection switch to the ON position. (**Refer to page 29.**)
Note that the terminating resistor switch should be set to the OFF position (initial status) when sharing the same encoder with another unit (NC, etc.) having a terminating resistor under the differential line driver setting.
For the complementary, set the switch to the OFF position.
- *8 For terminal compatibility of the FR-JCBL, FR-V7CBL, and FR-A8TP, refer to **page 35**.
- *9 A separate power supply of 5 V/12 V/15 V is necessary according to the encoder power specification. When the encoder output is the differential line driver type, only 5 V can be input. If using the 24 V power supply of the FR-A8TP, 24 V power can be supplied from terminal PG24.
Make the voltage of the external power supply the same as the encoder output voltage, and connect the external power supply between PG and SD.
The encoder and the power supply can be shared under orientation control, encoder feedback control, or vector control.
- *10 When a stop position command is input from outside, a plug-in option FR-A8AX is required. For the details of the external stop position command, refer to the Instruction Manual (Detailed) of the inverter.
- *11 To enable terminal OH, set **Pr.876 Thermal protector input** = "1 (initial value)".

5.2 Terminals

◆ Option FR-A8AX terminal

Terminal symbol	Terminal name	Description
X0 to X15	Digital signal input terminal	Input the digital signal at the relay contact or open collector terminal. Using Pr.360 , speed or position command is selected as the command signal entered.
DY	Data read timing input signal terminal	Use this terminal when a digital signal read timing signal is necessary. Data is read only during the DY signal is ON. The X0 to X15 data before the signal is turned OFF is retained by turning OFF the DY signal.

◆ Inverter terminal

Terminal (signal)	Terminal (signal) name	Description
Input	X22	Orientation command For the X22 signal input, set "22" in any of Pr.178 to Pr.182, Pr.185, or Pr.189 to assign the function.*1
Output	ORA	Orientation complete Output switches to Low if the orientation has stopped within the orientation complete width while the start and X22 signals are input. For the ORA signal output, set "27 (positive logic)" or "127 (negative logic)" in any of Pr.190 to Pr.192, or Pr.195 .*1
	ORM	Orientation fault Output switches to Low if the orientation has not stopped within the orientation complete width while the start and X22 signals are input. For the ORM signal output, set "28 (positive logic)" or "128 (negative logic)" in any of Pr.190 to Pr.192, or Pr.195 .*1

*1 Refer to the Instruction Manual (Detailed) of the inverter for the details of **Pr.178 to Pr.182, Pr.185, or Pr.189 (input terminal function selection) and Pr.190 to Pr.192, or Pr.195 (output terminal function selection)**.

5.3 Specifications

Repeated positioning accuracy	$\pm 1.5^\circ$ Depends on the load torque, moment of inertia of the load, orientation, creep speed, or position loop switching position, etc.
Permissible speed	Encoder-mounted shaft speed (6000 r/min with 1024 pulse encoder) The drive shaft and encoder-mounted shaft must be coupled directly or via a belt without any slip. Gear changing shafts cannot be applied.
Functions	Orientation, creep speed setting, stop position command selection, DC injection brake start position setting, creep speed and position loop switch position setting, position shift, orientation in-position, position pulse monitor, etc.
Holding force after positioning	Under V/F control, Advanced magnetic flux vector control without servo lock function Under vector control with servo lock function
Input signal (contact input)	Orientation command, forward and reverse rotation commands, stop position command (open collector signal input (complementary) is enabled) Binary signal of maximum 16 bits (when used with the FR-A8AX)
Output signal (open collector output)	Orientation completion signal, orientation fault signal

5.4 Parameter related to orientation control

5.4.1 Encoder orientation gear ratio setting

Set the encoder orientation gear ratio for machine end orientation control.

To perform machine end orientation control, the FR-A8TP and the plug-in option FR-A8AP must be installed.

Set "1" in **Pr.862 Encoder option selection**. Connect the motor-end encoder to the FR-A8TP, and connect the machine-end encoder to the FR-A8AP.

Pr.	Pr. group	Name	Initial value	Setting range	Description
394	A540	Number of machine side gear teeth	1	0 to 32767	Set the encoder orientation gear ratio.
395	A841	Number of motor side gear teeth			

Set the encoder orientation gear ratio.

- An accurate gear ratio (or pulley ratio) from the motor shaft to the spindle is necessary.

Set correct numbers of gear teeth in **Pr.394** and **Pr.395**.

$$\text{Pr.394} = A \times C \times E$$

$$\text{Pr.395} = B \times D \times F$$

Exercise care so that the $A \times C \times E$ and $B \times D \times F$ settings do not exceed 32767.

If either or both of them exceed that value, make approximations.

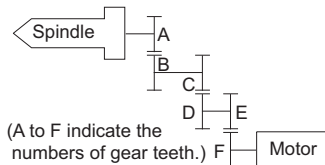

NOTE

- Pulley ratio Ratio of vector-driven motor side pulley diameter to spindle side pulley diameter

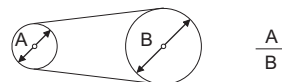

Spindle side Motor side

$$\frac{A}{B}$$

Setting example (When the numbers of gear teeth are as follows)

A:15, C: 43, E: 60, B: 10, D: 28, F:55

$$\mathbf{Pr.394} = 15 \times 43 \times 60 = 38700$$

$$\mathbf{Pr.395} = 10 \times 28 \times 55 = 15400$$

Since **Pr.394** setting exceeds 32767 at this time, make approximations as follows.

$$\frac{\mathbf{Pr.394}}{\mathbf{Pr.395}} = \frac{38700}{15400} = \frac{3870}{1540}$$

6 ENCODER FEEDBACK CONTROL

Mount FR-A8TP to an FR-A800 series inverter to perform encoder feedback control under V/F control or Advanced magnetic flux vector control.

This controls the inverter output frequency so that the motor speed is constant to the load variation by detecting the motor speed with the speed detector (encoder) to feed back to the inverter.

For the details of the parameters used for encoder feedback control, refer to the Instruction Manual (Detailed) of the inverter.

6.1 Connection diagram

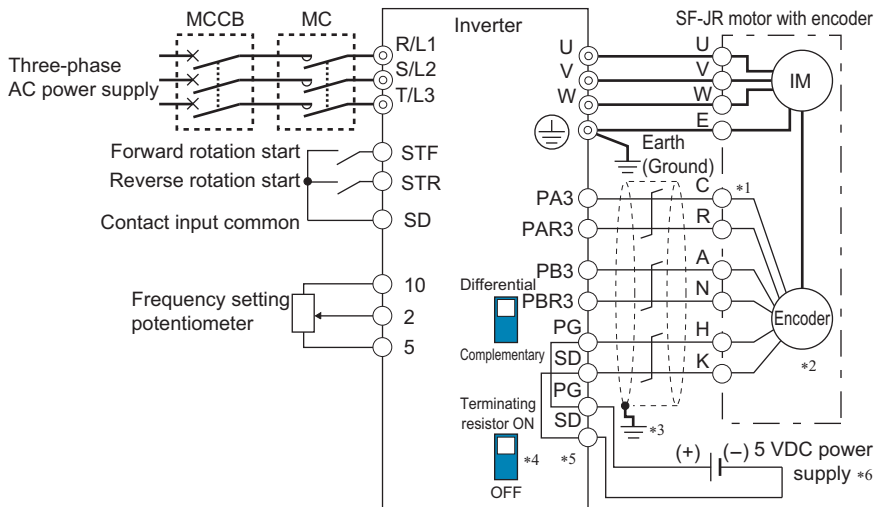

- *1 The pin number differs according to the encoder used.
- *2 Connect the encoder so that there is no looseness between the motor and motor shaft. Speed ratio must be 1:1.
- *3 Earth (ground) the shield of the encoder cable to the enclosure using a tool such as a P-clip. (Refer to [page 25.](#))
- *4 For the differential line driver, set the terminating resistor selection switch to the ON position. (Refer to [page 25.](#))
 Note that the terminating resistor switch should be set to the OFF position (initial status) when sharing the same encoder with another unit (NC, etc.) having a terminating resistor under the differential line driver setting.
 For the complementary, set the terminating resistor selection switch to the OFF position.
- *5 For terminal compatibility of the FR-JCBL, FR-V7CBL, and FR-A8TP, refer to [page 35.](#)
- *6 A separate power supply of 5 V/12 V/15 V is necessary according to the encoder power specification. When the encoder output is the differential line driver type, only 5 V can be input. If using the 24 V power supply of the FR-A8TP, 24 V power can be supplied from terminal PG24.
 Make the voltage of the external power supply the same as the encoder output voltage, and connect the external power supply between PG and SD.
 The encoder and the power supply can be shared under encoder feedback control, or orientation control.

6.2 Specifications

Speed variation ratio	±0.1% (100% means 3600 r/min)
Function	<ul style="list-style-type: none"> • Setting of the speed feedback range • Setting of the feedback gain • Setting of the encoder rotation direction
Maximum speed	V/F control: 590 Hz, Advanced magnetic flux vector control: 400 Hz (102400 pulses/s or less encoder pulses)

7 VECTOR CONTROL

When the FR-A8TP is mounted on the FR-A800 series, full-scale vector control operation can be performed using a motor with encoder. The speed control, torque control, and position control can be performed by vector control. (For the details, refer to the Instruction Manual (Detailed) of the inverter.)

7.1 Connection diagram

◆ Speed control

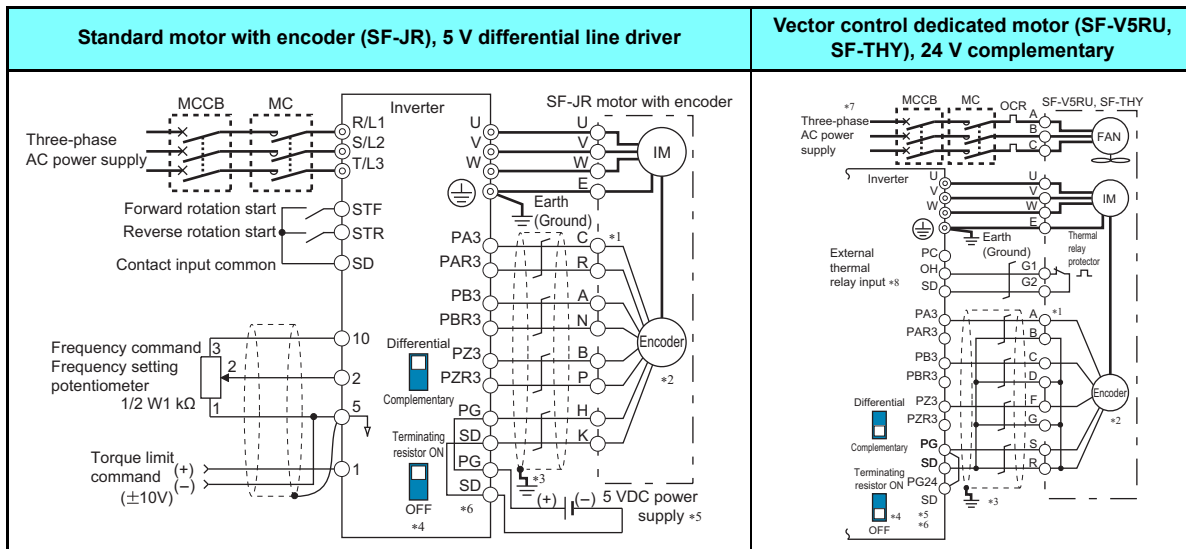

◆ Torque control

Standard motor with encoder (SF-JR), 5 V differential line driver

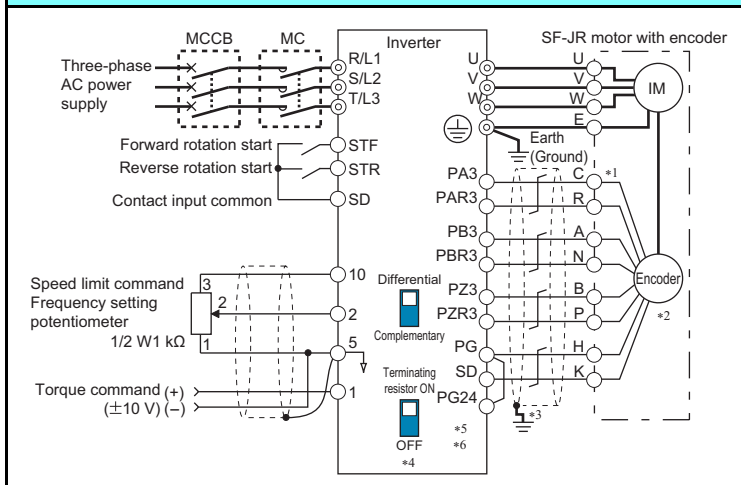

Vector control dedicated motor (SF-V5RU, SF-THY), 24 V complementary

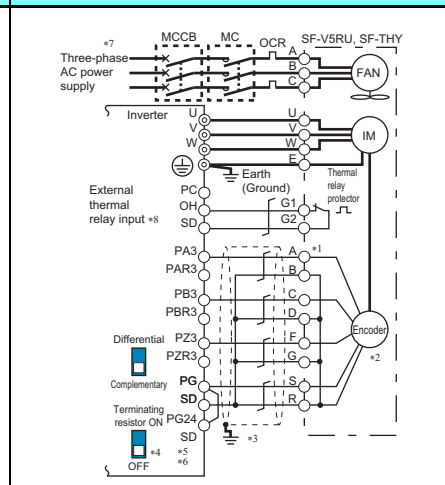

◆ Position control

Vector control dedicated motor (SF-V5RU, SF-THY), 24 V complementary

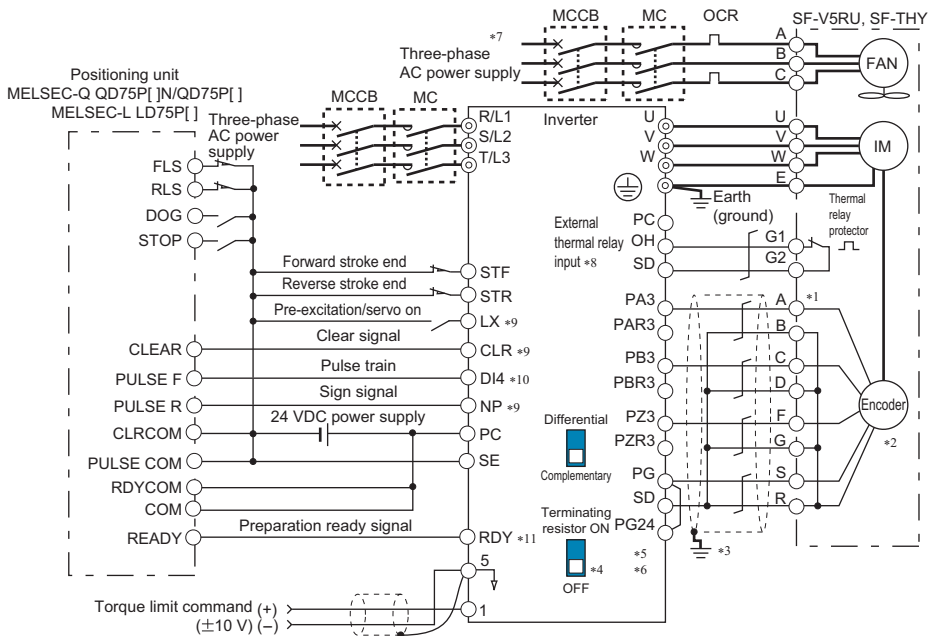

- *1 The pin number differs according to the encoder used.
Speed, control, torque control, and position control by pulse train input are available with or without the Z-phase being connected.
- *2 Connect the encoder so that there is no looseness between the motor and motor shaft. Speed ratio must be 1:1.
- *3 Earth (ground) the shield of the encoder cable to the enclosure using a tool such as a P-clip. (Refer to [page 29](#).)
- *4 For the complementary, set the terminating resistor selection switch to the OFF position (initial status). (Refer to [page 29](#).)
- *5 A separate power supply of 5 V/12 V/15 V is necessary according to the encoder power specification. When the encoder output is the differential line driver type, only 5 V can be input. If using the 24 V power supply of the FR-A8TP, 24 V power can be supplied from terminal PG24.
Make the voltage of the external power supply the same as the encoder output voltage, and connect the external power supply between PG and SD.
- *6 For terminal compatibility of the FR-JCBL, FR-V7CBL, and FR-A8TP, refer to [page 35](#).
- *7 For the fan of the 7.5 kW or lower dedicated motor, the power supply is single phase. (200 V/50 Hz, 200 to 230 V/60 Hz)
- *8 To enable terminal OH, set **Pr.876 Thermal protector input** = "1 (initial value)".
- *9 Assign the function using **Pr.178 to Pr.182, Pr.185, or Pr.189(input terminal function selection)** .
- *10 When position control is selected, terminal DI4 function is invalid and simple position pulse train input terminal becomes valid.
- *11 Assign the function using **Pr.190 to Pr.192, or Pr.195 (output terminal function selection)**.

7.2 Specifications

Speed control	Speed control range	1:1500 (both driving/regeneration*1)
	Speed variation ratio	±0.01% (100% means 3000 r/min)
	Speed response	130 Hz
	Maximum speed	400 Hz (102400 pulses/s or less encoder pulses)
Torque control	Torque control range	1:50
	Absolute torque accuracy	±10% *2
	Repeated torque accuracy	±5% *2
Position control	Repeated positioning accuracy	±1.5° (at motor shaft end)
	Maximum input pulse frequency	100 kpps (terminal DI4)
	Positioning feedback pulse	Number of encoder pulses per motor rotation (Pr.851) × 4
	Electronic gear setting	1/50 to 20
	In-position width	0 to 32767 pulses
	Error excess	0 to 400k pulses
Function		<ul style="list-style-type: none"> • Setting of speed feedback range • Setting of feedback gain • Setting of encoder rotation direction

*1 Regeneration unit (option) is necessary for regeneration.

*2 With online auto tuning (adaptive magnetic flux observer), dedicated motor, rated load

8 ENCODER PULSE DIVIDING OUTPUT

Pulse input of encoder connected to the inverter is divided and output from the FR-A8TP terminal.

8.1 Connection diagram

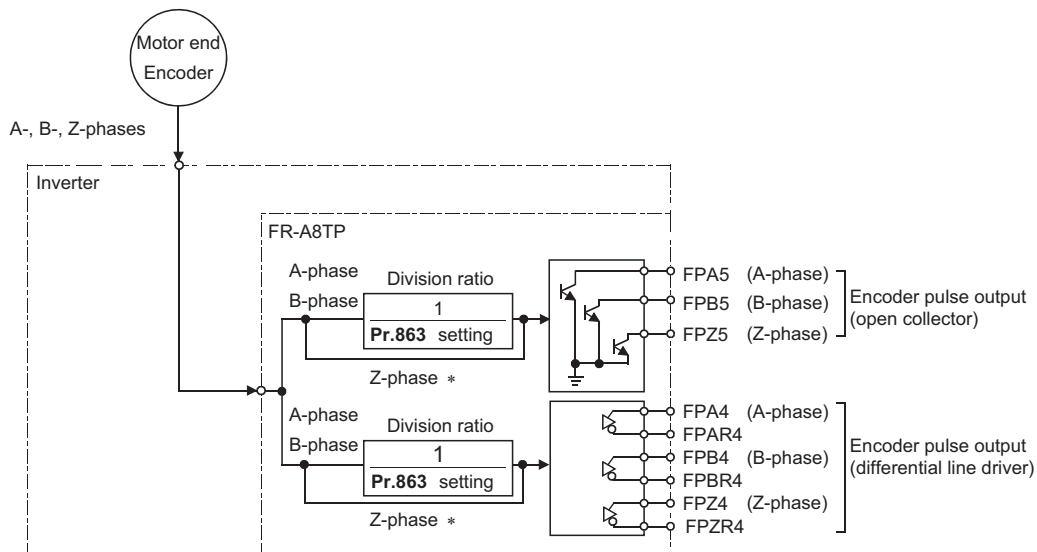

* Z-phase cannot be divided.

NOTE

- For open collector output, the signal may become unstable if the input resistance of the connected device is large and the device may detect the signal incorrectly. In this case, adding a pull-up resistor as shown below will improve the phenomenon.

Select a pull-up resistor in consideration of the input current of the connected device so that the open collector output current will not exceed the output permissible load current.

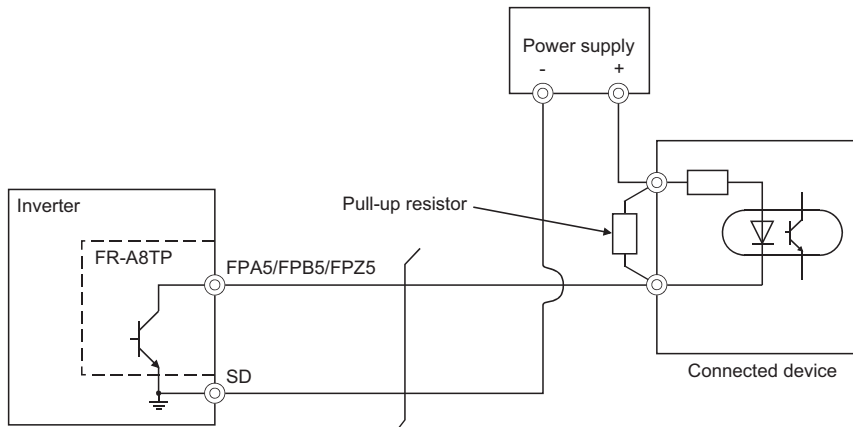

8.2 Parameter related to encoder pulse dividing output

Pr.	Pr. group	Name	Initial value	Setting range	Description
863	M600	Control terminal option-Encoder pulse division ratio	1	1 to 32767	The encoder pulse signal at the motor end can be divided in division ratio set in Pr.863 and output. Use this parameter to make the response of the machine to be input slower, etc.

- Division waveform by division ratio
Both ON-OFF width is division times. (50% duty)
- Pulse waveform example at 1000 pulse input when **Pr.863** = "2"

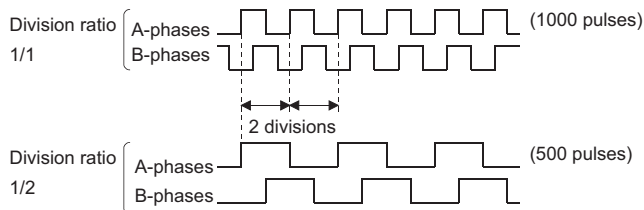

NOTE

- Control of forward rotation/reverse rotation by phase difference between A phase and B phase.
When A phase is 90° advanced as compared to B phase: forward rotation
When A phase is 90° behind as compared to B phase: reverse rotation

REVISIONS

*The manual number is given on the bottom left of the back cover.

Print date	*Manual number	Revision
Dec. 2014	IB(NA)-0600574ENG-A	First edition

INVERTER

