



INVERTER
Plug-in option
FR-A8NP
INSTRUCTION MANUAL

PROFIBUS-DP
communication function

PRE-OPERATION INSTRUCTIONS	1
INSTALLATION	2
WIRING	3
INVERTER SETTING	4
FUNCTIONS	5
PROFIBUS DEVICE DATA	6
PPO TYPE SUPPORT SPECIFICATION	7
PPO TYPE NON-SUPPORT SPECIFICATION	8
TROUBLESHOOTING	9

Thank you for choosing this Mitsubishi inverter plug-in option.

This Instruction Manual provides handling information and precautions for use of this product. Incorrect handling might cause an unexpected fault. Before using this product, always read this Instruction Manual carefully to use this product correctly.

Please forward this Instruction Manual to the end user.

Safety instructions

Do not attempt to install, operate, maintain or inspect the product until you have read through this Instruction Manual and appended documents carefully and can use the equipment correctly. Do not use this product until you have a full knowledge of the equipment, safety information and instructions. In this Instruction Manual, the safety instruction levels are classified into "Warning" and "Caution".



Warning

Incorrect handling may cause hazardous conditions, resulting in death or severe injury.



Caution

Incorrect handling may cause hazardous conditions, resulting in medium or slight injury, or may cause only material damage.



Caution

The **Caution** level may even lead to a serious consequence according to conditions. Both instruction levels must be followed because these are important to personal safety.

◆ Electric Shock Prevention



Warning

- While the inverter power is ON, do not open the front cover or the wiring cover. Do not run the inverter with the front cover or the wiring cover removed. Otherwise you may access the exposed high voltage terminals or the charging part of the circuitry and get an electric shock.
- Do not remove the inverter front cover even if the power supply is disconnected. The only exception for this would be when performing wiring and periodic inspection. You may accidentally touch the charged inverter circuits and get an electric shock.
- Before wiring or inspection, LED indication of the inverter unit operation panel must be switched OFF. Any person who is involved in wiring or inspection shall wait for at least 10 minutes after the power supply has been switched OFF and check that there is no residual voltage using a tester or the like. For some time after the power-OFF, a high voltage remains in the smoothing capacitor, and it is dangerous.
- Any person who is involved in wiring or inspection of this equipment shall be fully competent to do the work.
- The plug-in option must be installed before wiring. Otherwise you may get an electric shock or be injured.
- Do not touch the plug-in option or handle the cables with wet hands. Otherwise you may get an electric shock.
- Do not subject the cables to scratches, excessive stress, heavy loads or pinching. Otherwise you may get an electric shock.

◆ Injury Prevention



Caution

- The voltage applied to each terminal must be the ones specified in the Instruction Manual. Otherwise a burst, damage, etc. may occur.
- The cables must be connected to the correct terminals. Otherwise a burst, damage, etc. may occur.
- The polarity (+ and -) must be correct. Otherwise a burst or damage may occur.
- While power is ON or for some time after power OFF, do not touch the inverter as it will be extremely hot. Touching these devices may cause a burn.

◆ Additional Instructions

The following instructions must be also followed. If the product is handled incorrectly, it may cause unexpected fault, an injury, or an electric shock.

Caution

Transportation and mounting

- Do not install or operate the plug-in option if it is damaged or has parts missing.
- Do not stand or rest heavy objects on the product.
- The mounting orientation must be correct.
- Foreign conductive objects must be prevented from entering the inverter. That includes screws and metal fragments or other flammable substance such as oil.
- If halogen-based materials (fluorine, chlorine, bromine, iodine, etc.) infiltrate into a Mitsubishi product, the product will be damaged. Halogen-based materials are often included in fumigant, which is used to sterilize or disinfest wooden packages. When packaging, prevent residual fumigant components from being infiltrated into Mitsubishi products, or use an alternative sterilization or disinfection method (heat disinfection, etc.) for packaging. Sterilization or disinfection of wooden package should also be performed before packaging the product.

Trial run

- Before starting operation, each parameter must be confirmed and adjusted. A failure to do so may cause some machines to make unexpected motions.

Warning

Usage

- Do not modify the equipment.
- Do not perform parts removal which is not instructed in this manual. Doing so may lead to fault or damage of the product.

Caution

Usage

- When parameter clear or all parameter clear is performed, the required parameters must be set again before starting operations. Because all parameters return to their initial values.
- Static electricity in your body must be discharged before you touch the product.

Maintenance, inspection and parts replacement

- Do not carry out a megger (insulation resistance) test.

Disposal

- The inverter must be treated as industrial waste.

General instruction

- Many of the diagrams and drawings in this Instruction Manual show the inverter without a cover or partially open for explanation. Never operate the inverter in this manner. The cover must be reinstalled and the instructions in the Instruction Manual must be followed when operating the inverter.

– CONTENTS –

1	PRE-OPERATION INSTRUCTIONS	7
1.1	Unpacking and product confirmation.....	7
1.2	Component names	8
1.3	Specifications	9
1.3.1	Inverter option specifications	9
1.3.2	Communication specifications	9
2	INSTALLATION	10
2.1	Pre-installation instructions	10
2.2	Installation procedure	11
2.3	Node address switch setting	15
3	WIRING	16
3.1	Terminals.....	16
3.2	Wiring.....	17
4	INVERTER SETTING	20
4.1	Parameter list.....	20
4.2	Operation mode setting	22
4.2.1	Operation mode switching and communication startup mode (Pr.79, Pr.340).....	22
4.3	Operation at communication error occurrence	25
4.3.1	Operation selection at communication error occurrence (Pr.500 to Pr.502, Pr.779)	25
4.3.2	Fault and measures	29
4.4	Inverter reset.....	30
5	FUNCTIONS	32
5.1	Output from the inverter to the network.....	32

5.2	Input to the inverter from the network.....	33
6	PROFIBUS DEVICE DATA	34
6.1	Device data (GSD file)	34
6.2	Slave user parameter	39
7	PPO TYPE SUPPORT SPECIFICATION	40
7.1	PROFIBUS profiles	40
7.1.1	Setting the PROFIBUS format (Pr.1110)	40
7.2	ID definitions	42
7.3	Buffer memory configuration	43
7.4	Buffer memory details	45
7.5	Outline of PNU	54
7.6	PROFIBUS PNU	55
7.6.1	Real-time monitor.....	55
7.6.2	Parameter clear	56
7.6.3	Operation mode read/write	56
7.6.4	Set frequency read.....	56
7.6.5	Terminal input read	57
7.6.6	Inverter reset.....	57
7.6.7	REF command assignment (available only when the extended format is selected) (only for the FR-A800 series).....	57
7.6.8	STS monitor function (available only when the extended format is selected) (only for the FR-A800 series).....	59
7.6.9	Node address read	59
7.6.10	Faults history read	60
7.6.11	PNU list read.....	64
7.7	Standard parameters	65
7.8	PROFIBUS-DP communication function setting	68
7.8.1	PROFIBUS communication command source setting (Pr.1109) (only for the FR-A800 series)	68
7.8.2	Torque command / torque limit via PROFIBUS communication (Pr.804) (only for the FR-A800 series).....	69
7.8.3	Torque bias selection (Pr.840) (only for the FR-A800 series).....	70
7.8.4	Frequency command with sign (Pr.541)	71

8 PPO TYPE NON-SUPPORT SPECIFICATION

72

8.1	PROFIBUS profiles	72
8.2	ID definitions	73
8.3	Buffer memory configuration	74
8.4	Buffer memory details	75
8.5	Outline of PNU	79
8.6	PROFIBUS PNU (module type A5NP)	80
8.6.1	Real-time monitor area (IND=H0000 (IND=H00, PP=H00))	80
8.6.2	System environment variable (sev) area (IND = H01PP (IND = H01, PP = H00, H01))	81
8.7	Standard parameters	85
8.7.1	Normal parameter area (IND = H0200 (IND = H02, PP = H00))	85
8.7.2	Pr.900 to calibration parameter (frequency) area (IND=H0300 (IND=H03, PP=H00))	86
8.7.3	Pr.900 to calibration parameter (%) area (IND=H0400 (IND=H04, PP=H00))	87

9 TROUBLESHOOTING

88

MEMO



1 PRE-OPERATION INSTRUCTIONS

1.1 Unpacking and product confirmation

Take the plug-in option out of the package, check the product name, and confirm that the product is as you ordered and intact. This product is a plug-in option for the FR-A800/F800 series inverter.

◆ Product confirmation

Check the enclosed items.

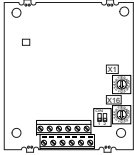
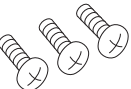
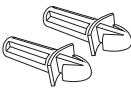
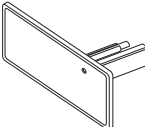
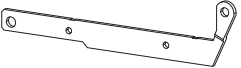
<p>Plug-in option1</p> 	<p>Mounting screw (M3 × 8 mm)3 (Refer to page 12.)</p> 	<p>Spacer2 (Refer to page 12.)</p> 	<p>Communication option LED display cover1 (Refer to page 11.)</p> 
<p>Earth plate1 (Refer to page 12.)</p> 			

NOTE

- PROFIBUS® is a registered trademark of PROFIBUS User Organization.

1.2 Component names

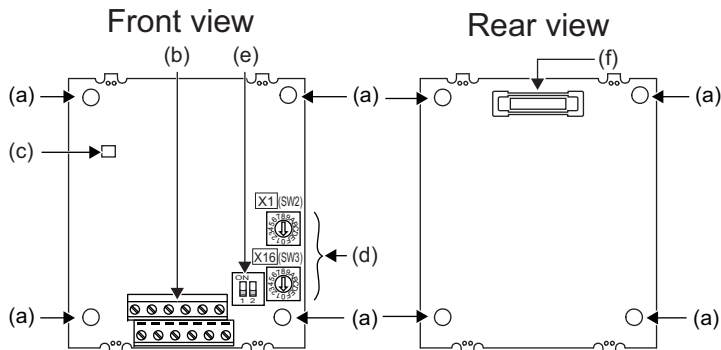
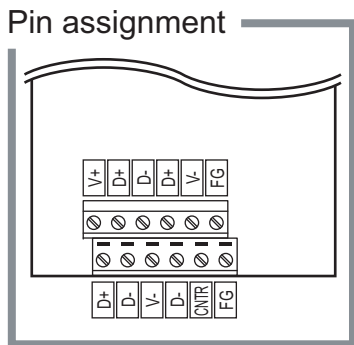

Symbol	Name	Description	Refer to page								
a	Mounting hole	Fixes the option to the inverter with screws, or installs spacers.	12								
b	Terminal block	Connect the communication cable.	16								
c	Operation status (LED)	ON/OFF indicator of the LED indicates inverter operation status. <table border="1" data-bbox="500 658 1137 803"> <thead> <tr> <th>LED status</th> <th>Description</th> </tr> </thead> <tbody> <tr> <td>OFF</td> <td>Inverter power OFF</td> </tr> <tr> <td>Red (ON)</td> <td>A communication error with the master occurred</td> </tr> <tr> <td>Green (ON)</td> <td>During communication with the master</td> </tr> </tbody> </table>	LED status	Description	OFF	Inverter power OFF	Red (ON)	A communication error with the master occurred	Green (ON)	During communication with the master	—
LED status	Description										
OFF	Inverter power OFF										
Red (ON)	A communication error with the master occurred										
Green (ON)	During communication with the master										
d	Node address switch	Set the inverter address within the range of H00 to H7D.	15								
e	Switch for manufacturer setting	Do not change from initially-set status. (The switches 1 and 2 are both OFF.)	—								
f	Connector	Connect to the inverter option connector.	12								

1.3 Specifications

1.3.1 Inverter option specifications

Type	Inverter plug-in option type
Number of nodes occupied	One inverter occupies one node.
Connection cable	Cable which supports 12.0 Mbps communication (EIA-485(RS-485) standard)

1.3.2 Communication specifications

Communication speed	Wiring length 1200 m or less	9600 bps, 19.2 Kbps, 93.75 Kbps
	Wiring length 600 m or less	187.5 Kbps
	Wiring length 200 m or less	500 Kbps, 1.5 Mbps
	Wiring length 100 m or less	3.0 Mbps, 6.0 Mbps, 12.0 Mbps

2 INSTALLATION

2.1 Pre-installation instructions

Check that the inverter's input power and the control circuit power are both OFF.



Caution

- With input power ON, do not install or remove the plug-in option. Otherwise, the inverter and plug-in option may be damaged.
- To avoid damage due to static electricity, static electricity in your body must be discharged before you touch the product.

2.2 Installation procedure

◆ Installing the communication option LED display cover

- (1) Remove the inverter front cover. (Refer to Chapter 2 of the Instruction Manual (Detailed) of the inverter for details on how to remove the front cover.)
Mount the cover for displaying the operation status indication LED for the communication option on the inverter front cover.
- (2) Cut off hooks on the rear of the inverter front cover with nipper, etc. and open the window for fitting the LED display cover.

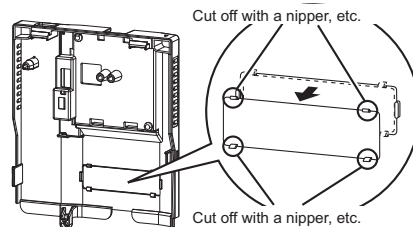

- (3) Fit the communication option LED display cover to the front side of the front cover. Align the LED display cover with the LED position on the circuit board of the option. Push the LED display cover until it is fixed with the hooks.

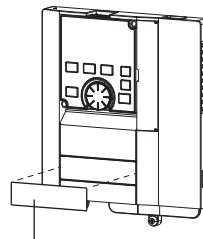

Communication option LED display cover

Caution

- Take care not to hurt your hand and such with portions left by cutting hooks of the rear of the front cover.

◆ Installing the option

- (1) For the two mounting holes (as shown in the next page) that will not be tightened with mounting screws, insert spacers.
- (2) Fit the connector of the plug-in option to the guide of the connector on the inverter unit side, and insert the plug-in option as far as it goes. (Insert it to the inverter option connector 1.)
- (3) Fit the one location on the left of the earth plate (as shown in the next page) securely to the inverter unit by screwing in the supplied mounting screw. (tightening torque 0.33 N·m to 0.40 N·m)
- (4) Fit the one location on the left of the plug-in option securely to the inverter unit and the right of the plug-in option to the inverter unit together with the earth plate by screwing in the supplied mounting screws. (tightening torque 0.33 N·m to 0.40 N·m) If the screw holes do not line up, the connector may not be inserted deep enough. Check the connector.

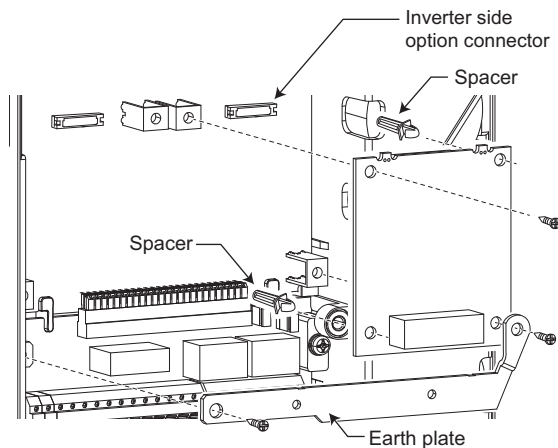

Example of installation to connector 1

Do not insert the plug-in option to the connector 2 or 3.

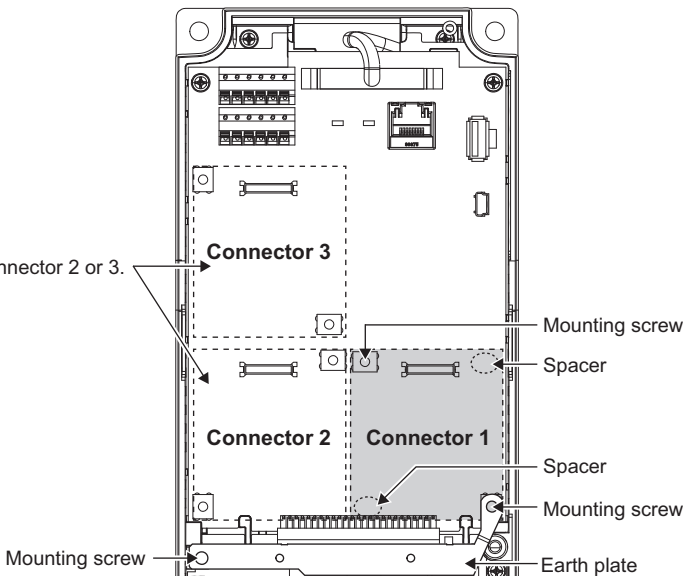

Insertion positions for screws and spacers

 **NOTE**

- When mounting/removing the plug-in option, hold the sides of the option. Do not press on the parts on the option circuit board. Stress applied to the parts by pressing, etc. may cause a failure.
- Caution must be applied to mounting screws falling off when removing and mounting the plug-in option.
- When using this plug-in option, insert it to the inverter option connector 1. If it is inserted to the option connector 2 or 3, the protective function (E.2 or E.3) is activated and the inverter will not operate.
- Even if the option is inserted to the option connector 1, when the inverter cannot recognize that the option is mounted due to improper installation, etc., the protective function (E.1) is activated.

Mounted position	Fault indication
Option connector 1	E. 1
Option connector 2	E. 2
Option connector 3	E. 3

- When removing the plug-in option, remove the two screws on the left and right, then pull it straight out. Pressure applied to the connector and to the option board may break the option.
- Always attach the earth plate because a malfunction due to noises may occur without it.

2.3 Node address switch setting

Set the node address between "H00" and "H7D" using the node address switches on the FR-A8NP board. (Refer to [page 8](#).)
The setting is applied at the next power-ON.

Set the arrow (↑) of the corresponding switches to a number or an alphabet to set a desired address.

- Setting example

<p>Node address 1: Set the "↑" of X16 (SW3) to "0" and the "↑" of X1 (SW2) to "1".</p>	<p>Node address 38 (H26): Set the "↑" of X16 (SW3) to "2" and the "↑" of X1 (SW2) to "6".</p>
--	---

NOTE

- Set the inverter node address before switching ON the inverter and do not change the setting while power is ON. Otherwise you may get an electric shock.
- Set the node address switch to the switch number (alphabet) position correctly. If the switch is set between numbers, normal data communication cannot be established.

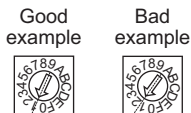

- When the node address switches are set to any of H7E to HFF, the node address is recognized as H7D.
- The node addresses, H00, H01, H02, H7C, and H7D, may not be available for some master modules.
- You cannot set the same node address to other devices on the network. (Doing so disables proper communication.)

3.1 Terminals

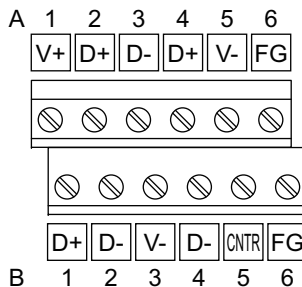

Terminal no.	Terminal name	Definition
1-A	V+ (VP) *1	Voltage output (approx. 5 V to V-)
1-B	D+ (RXD/TXD-P)	Sends and receives PROFIBUS signal+ (B-line)
2-A	D+ (RXD/TXD-P) *1	Sends and receives PROFIBUS signal+ (B-line)
2-B	D+ (RXD/TXD-N)	Sends and receives PROFIBUS signal- (A-line)
3-A	D+ (RXD/TXD-N) *1	Sends and receives PROFIBUS signal- (A-line)
3-B	V- (DGND)	GND of D+/D-
4-A	D+ (RXD/TXD-P) *1	(To connect a terminating resistor)
4-B	D+ (RXD/TXD-N) *1	(To connect a terminating resistor)
5-A	V- (DGND) *1	GND of D+/D-
5-B	CNTR *2	Control signal (sending request from the inverter)
6-A	FG	(Connected to the earth of the inverter unit)
6-B	FG	(Connected to the earth of the inverter unit)

*1 When connecting a terminating resistor, connect the terminating resistor to these terminals. (Refer to [page 19](#))

*2 It may not be necessary depending on the master used.

3.2 Wiring

Use the network connection cable which supports 12.0 Mbps communication.

(1) Strip off the sheath of the PROFIBUS communication dedicated cable and wind wires and shield cables to use.

Strip off the sheath for the below length. If the length of the sheath peeled is too long, a short circuit may occur with neighboring wires. If the length is too short, wires might come off.

Wire the stripped cable after twisting it to prevent it from becoming loose. In addition, do not solder it.

Cable stripping length

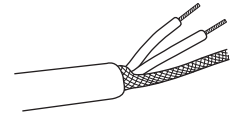
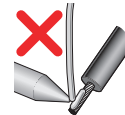
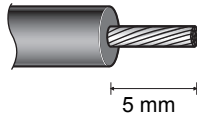

Use a blade terminal as necessary.

When using the blade terminal, use care so that the twisted wires do not come

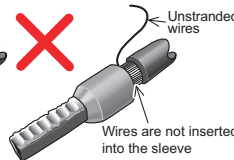
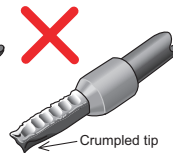
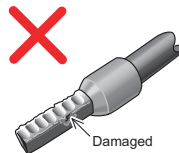
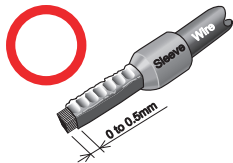

- Blade terminal commercially available (as of February 2012. The product may be changed without notice.)

Terminal screw size	Wire size (mm ²)	Ferrule terminal model		Manufacturer	Crimping tool name
		with insulation sleeve	without insulation sleeve		
M2	0.3 to 0.5	Al 0,5-6WH	A 0,5-6	Phoenix Contact Co.,Ltd.	CRIMPFOX 6

- (2) Loosen the terminal screw and insert the cable into the terminal.
Tighten each cable with fixing screws to the recommended tightening torque.

<Cable connection example>

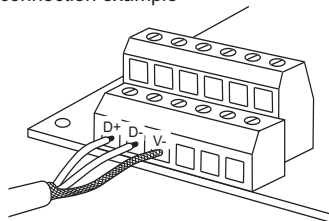

<Connection example of multiple inverters>

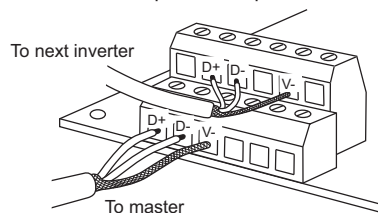

Screw size	Tightening torque	Cable size	Screwdriver
M2	0.22 N•m to 0.25 N•m	0.3 mm ² to 0.75 mm ²	Small ⊖ flat-blade screwdriver (Tip thickness: 0.4 mm / tip width: 2.5 mm)

NOTE

- Undertightening can cause cable disconnection or malfunction. Overtightening can cause a short circuit or malfunction due to damage to the screw or unit.

(3) Terminating resistor

Connect terminating resistors to the both ends of a network if the both ends are FR-A8NP-mounted inverters.

Connection example

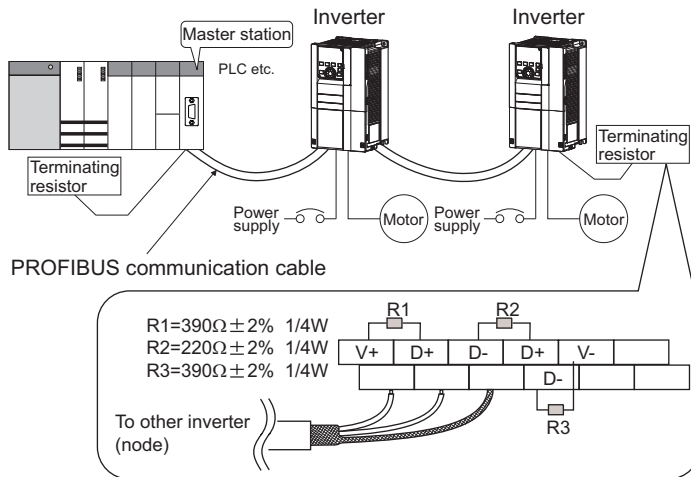

3

Caution

- After wiring, wire offcuts must not be left in the inverter. They may cause an error, failure or malfunction.

4 INVERTER SETTING

4.1 Parameter list

The following parameters are used for the communication option (FR-A8NP).

Set the values according to need.

Pr.	Pr. group	Name	Setting range	Minimum setting increments	Initial value	Refer to page
79	D000	Operation mode selection	0 to 4, 6, 7	1	0	22
338	D010	Communication operation command source	0, 1	1	0	*4
339	D011	Communication speed command source	0, 1, 2	1	0	*4
340	D001	Communication startup mode selection	0, 1, 2, 10, 12	1	0	22
342	N001	Communication EEPROM write selection	0, 1	1	0	*4
349*1	N010*1	Communication reset selection	0, 1	1	0	31
500*1	N011*1	Communication error execution waiting time	0 to 999.8 s	0.1 s	0 s	25
501*1	N012*1	Communication error occurrence count display	0	1	0	26
502	N013	Stop mode selection at communication error	0 to 3	1	0	26
541*1	N100*1	Frequency command sign selection	0, 1	1	0	71
550*3	D012*3	NET mode operation command source selection	0, 1, 9999	1	9999	*4
779	N014	Operation frequency during communication error	0 to 590 Hz, 9999	0.01 Hz	9999	26
804*5	D400*5	Torque command source selection	0, 1, 3 to 6	1	0	69
840 *2, *5	G230 *2, *5	Torque bias selection	0 to 3, 24, 25, 9999	1	9999	70

Pr.	Pr. group	Name	Setting range	Minimum setting increments	Initial value	Refer to page
1109 *1, *5	G320 *1, *5	PROFIBUS communication command source selection	0, 1, 10, 11, 20, 21, 100, 101, 110, 111, 120, 121, 1000, 1001, 1010, 1011, 1020, 1021, 1100, 1101, 1110, 1111, 1120, 1121	1	0	68
1110 *1, *3, *5	N190 *1, *3, *5	PROFIBUS format selection	0, 1	1	0	40

- *1 Parameters which can be displayed when the plug-in option (FR-A8NP) is mounted.
- *2 Parameters which can be displayed when the plug-in option (FR-A8AP) is mounted.
- *3 The setting is applied after an inverter reset or power-ON.
- *4 For the parameter details, refer to the Instruction Manual (Detailed) of the inverter.
- *5 The setting is available only for the FR-A800 series.

4.2 Operation mode setting

4.2.1 Operation mode switching and communication startup mode (Pr.79, Pr.340)

◆ Operation mode switching conditions

Operation mode switching conditions

- The inverter is at a stop;
- Both the STF and STR signals are off; and
- The **Pr.79 Operation mode selection** setting is correct.
(Set with the operation panel of the inverter.)

◆ Operation mode selection at power ON and at restoration from instantaneous power failure

The operation mode at power ON and at restoration from instantaneous power failure can be selected.

Set a value other than "0" in **Pr.340 Communication startup mode selection** to select the network operation mode.

After started in network operation mode, parameter write from the network is enabled.



- Change of the **Pr.340** setting is valid when powering on or resetting the inverter.
- **Pr.340** can be changed with the operation panel independently of the operation mode.
- When setting a value other than 0 in **Pr.340**, make sure that the initial settings of the inverter are correct.
- Refer to the Instruction Manual (Detailed) of the inverter for details of **Pr.79, Pr.340**.

Pr.340 setting	Pr.79 setting	Operation mode at power ON or power restoration	Operation mode switchover
0 (initial value)	0 (initial value)	External operation mode	Switching among the External, PU, and NET operation mode is enabled *1, *5
	1	PU operation mode	PU operation mode fixed
	2	External operation mode	Switching between the External and Net operation mode is enabled *5 Switching to the PU operation mode is disallowed
	3, 4	External/PU combined operation mode	Operation mode switching is disallowed
	6	External operation mode	Switching among the External, PU, and NET operation mode is enabled while running. *5
	7	X12 (MRS) signal ON: external operation mode	Switching among the External, PU, and NET operation mode is enabled *1, *5
X12 (MRS) signal OFF: external operation mode		External operation mode fixed (Forcibly switched to External operation mode.)	
1, 2 *2	0	NET operation mode	Same as when Pr.340 = "0"
	1	PU operation mode	
	2	NET operation mode	
	3, 4	External/PU combined operation mode	
	6*	NET operation mode	
	7	X12 (MRS) signal ON..... NET operation mode	
		X12 (MRS) signal OFF.....external operation mode	

Pr.340 setting	Pr.79 setting	Operation mode at power ON or power restoration	Operation mode switchover
10, 12 *2	0	NET operation mode	Switching between the PU and NET operation mode is enabled *3, *5
	1	PU operation mode	Same as when Pr.340 = "0"
	2	NET operation mode	NET operation mode fixed
	3, 4	External/PU combined operation mode	Same as when Pr.340 = "0"
	6*4	NET operation mode	Switching between the PU and NET operation mode is enabled while running *3, *5
	7	External operation mode	Same as when Pr.340 = "0"

*1 Operation mode can not be directly changed between the PU operation mode and Network operation mode.

*2 The Pr.340 settings "2, 12" are mainly used for communication operation using the inverter RS-485 terminal.

When a value other than "9999" (selection of automatic restart after instantaneous power failure) is set in Pr.57 Restart coasting time, the inverter will resume the same operation state which was in before after power has been restored from an instantaneous power failure.

When Pr.340 = "1, 10", a start command turns off if power failure has occurred and then restored during a start command is on.

*3 Switching between the PU and NET operation modes is available with the key on the operation panel or the X65 signal.

*4 Pr.79 = "6" and Pr.128 to Pr.134 (PID control) are not activated simultaneously. The switchover mode and the PID control are disabled, and the inverter performs the same operation as when "0" is set in Pr.79.

*5 Refer to page 56, 83 for a switching method from the network.

4.3 Operation at communication error occurrence

4.3.1 Operation selection at communication error occurrence (Pr.500 to Pr.502, Pr.779)

You can select operations at communication error occurrences by setting **Pr.500 to Pr.502, Pr.779** under network operation.

◆ **Waiting time for the communication line error output after a communication error**

Waiting time for the communication error output after a communication line error occurrence can be set.

Pr.	Name	Setting range	Minimum setting increments	Initial value
500	Communication error execution waiting time	0 to 999.8 s	0.1 s	0 s

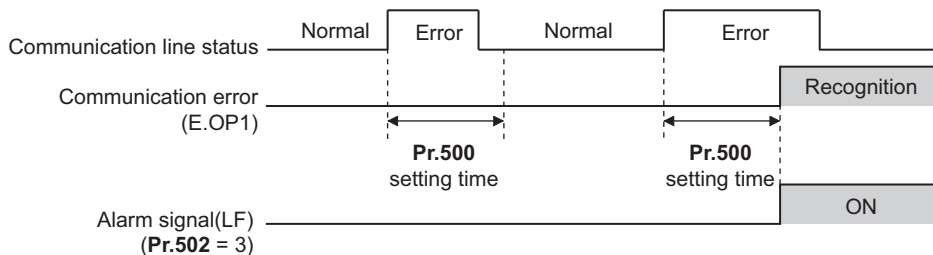

When a communication line error occurs and lasts longer than the time set in **Pr.500**, it is recognized as a communication error. If the communication returns to normal within the time, it is not recognized as a communication error, and the operation continues.

◆ Displaying and clearing the communication error count

The cumulative count of communication error occurrences can be displayed. Write "0" to clear this cumulative count.

Pr.	Name	Setting range	Minimum setting increments	Initial value
501	Communication error occurrence count display	0	1	0

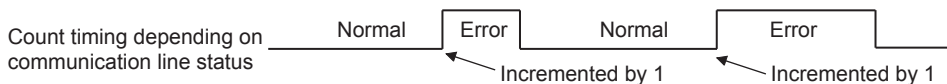

At the point of communication line error occurrence, **Pr.501 Communication error occurrence count display** is incremented by 1.

NOTE

- Communication error count is temporarily stored in the RAM memory. The error count is stored in EEPROM only once per hour. If power reset or converter reset is performed, **Pr.501** setting will be the one that is last stored to EEPROM depending on the reset timing.

◆ Inverter operation at a communication error occurrence

How the inverter operates at a communication line error or an option unit fault can be set.

Pr.	Name	Setting range	Description
502	Stop mode selection at communication error	0 (Initial Value), 1, 2, 3	Refer to page 27
779-1	Operation frequency during communication error	0 to 590 Hz	When a communication error occurs, the inverter operates at the set frequency.
		9999 (Initial Value)	The inverter operates at the frequency set before the communication error occurs.

*1 Valid when **Pr.502** = "3".

◆ About setting

- Operation at an error occurrence

Error definition	Pr.502 setting	Operation	Indication	Fault output
Communication line	0	Continued*1	Normal indication*1	Not provided*1
	1			
	2			
	3			
Communication option itself	0, 3	Coast to stop	E. 1 lit	Provided
	1, 2	Decelerated to stop	E. 1 lit after stop	Provided after stop

*1 When the communication returns to normal within the time period set in **Pr.500**, the communication option error (E.OP1) does not occur.

- Operation after the time in **Pr.500** elapses after an error occurrence

Error definition	Pr.502 setting	Operation	Indication	Fault output
Communication line	0	Coast to stop	E.OP1 lit	Provided
	1	Decelerated to stop	E.OP1 lit after stop	Provided after stop
	2			
	3	Continues operation with the Pr.779 setting.	Normal indication	Not provided
Communication option itself	0, 3	Kept stopped*2	E.OP1 kept lit*2	Kept provided*2
	1, 2			

*2 When an error occurs, the motor is decelerated or coasts to stop, and outputs the fault, independently of the **Pr.500** setting.

- Operation at error removal

Error definition	Pr.502 setting	Operation	Indication	Fault output
Communication line	0	Kept stopped	E.OP1 kept lit	Kept provided
	1			
	2	Restart	Normal indication	Not provided
	3	Normal operation		
Communication option itself	0, 3	Kept stopped	E. 1 kept lit	Kept provided
	1, 2			

NOTE

- The protective function [E.OP1 (fault data: HA1)] is activated at error occurrences on the communication line. The protective function [E.1 (fault data: HF1)] is activated at error occurrences in the communication circuit inside the option.
- Fault output indicates the fault (ALM) signal and fault bit output.
- When the fault output setting is active, fault records are stored in the faults history. (A fault record is written to the faults history at a fault output.)
When the fault output setting is not active, fault record is overwritten to the faults history temporarily but not stored. After the error is removed, the fault indication is reset, changing the display back to normal, and the last fault is displayed in the faults history.
- When the **Pr.502** setting is "1" or "2", the deceleration time is the ordinary deceleration time setting (e.g. **Pr.8**, **Pr.44**, **Pr.45**).
- The acceleration time at a restart is the ordinary acceleration time setting (e.g. **Pr.7**, **Pr.44**).
- When the **Pr.502** setting is "2", the operation/speed command at a restart is the one given before the error occurrence.
- When a communication line error occurs at the **Pr.502** setting of "2", removing the error during deceleration causes acceleration to restart at that point. (Acceleration is not restarted if the error is that of the option unit itself.)
- When **Pr.502** = "3", in order to continue the operation in the case of a communication line error, provide a safety stop countermeasure other than via communication. One counter measure is to input a signal to the terminal RES.

4.3.2 Fault and measures

◆ Inverter operation in each operation mode at error occurrences

Location	Status		Operation mode		
			Network operation	External operation	PU operation
Inverter	Inverter operation		Inverter trip	Inverter trip	Inverter trip
	Data communication		Continued	Continued	Continued
Communication line	Inverter operation		Inverter trip *1	Continued	Continued
	Data communication		Stop	Stop	Stop
Communication option	Communication option connection error	Inverter operation	Inverter trip *1	Inverter trip *1	Inverter trip *1
		Data communication	Continued	Continued	Continued
	Error of communication option itself	Inverter operation	Inverter trip *1	Continued	Continued
		Data communication	Stop	Stop	Stop

*1 Depends on the Pr.502 setting.

◆ Measures at error occurrences

Fault indication	Error definition	Measures
E.OP1	Communication line error	Check the LED status of the option unit and remove the cause of the alarm. (Refer to page 8 for LED indication status) • Check the other nodes on the network. • Inspect the master.
E.1, E.2, E.3	Option fault	• Insert the communication option to the inverter option connector 1. • Check the connection between the inverter and option unit for poor contact, etc. and remove the cause of the error.

*1 When faults other than the above are displayed, refer to the Instruction Manual (Detailed) of the inverter and remove the cause of the error.

4.4 Inverter reset

◆ Operation conditions of inverter reset

Which resetting method is allowed or not allowed in each operation mode is described below.

Resetting method			Operation mode		
			Network operation	External operation	PU operation
Reset from the network	Inverter reset (Refer to page 57)*1		Allowed	Disallowed	Disallowed
	Error reset (STW (bit 7)) at inverter fault (Refer to page 47)*2	Pr.349 = 0	Allowed	Allowed	Allowed
Pr.349 = 1		Allowed	Disallowed	Disallowed	
Turn on the inverter RES signal (terminal RES)			Allowed	Allowed	Allowed
Switch off inverter power			Allowed	Allowed	Allowed
Reset from the PU/ DU	Inverter reset		Allowed	Allowed	Allowed
	Reset at inverter fault		Allowed	Allowed	Allowed

*1 Inverter reset can be made any time.

*2 Reset can be made only when the protective function of the inverter is activated. (Available with PPO type 1 to 5 only)



NOTE

- When a communication line error has occurred, reset cannot be made from the network.
- The inverter is set to the External operation mode if it has been reset in Network operation mode in the initial status. To resume the network operation, the inverter must be switched to the Network operation mode again. Set a value other than "0" in **Pr.340** to start in the Network operation mode. (Refer to [page 22](#).)
- The inverter can not be controlled for about 1 s after release of a reset command.

◆ Error reset operation selection at inverter fault

An error reset command from communication option can be invalid in the External operation mode or PU operation mode.
An error reset command from the network is requested by STW (bit 7) (PPO type 1 to 5). (Refer to [page 47](#))

Pr.	Name	Initial value	Setting range	Function
349	Communication reset selection	0	0	Error reset is enabled independently of operation mode
			1	Error reset is enabled only in the network operation mode

5.1 Output from the inverter to the network

Main items to be output from the inverter (FR-A8NP) to the network and their descriptions are explained below.

Item	Description	Refer to page	
		PPO type support specification	PPO type non-support specification
Inverter monitor	Monitor various items such as inverter output frequency and output current.	48, 55	80
Parameter read	Read parameter settings of the inverter.	45, 65	75, 85
Inverter status	Monitor output signal of the inverter.	48	77
Operation mode read	Read the operation mode of the inverter.	48, 56	—
Set frequency read	Read the frequency set in the inverter.	56	83
Terminal input read	Read the analog value of terminal 2, 4, 1.	57	83
Node address read	Read node address of the inverter.	59	—
Alarm definition read	Monitor alarm history occurred in the inverter and energization time, output frequency, output current and output voltage at alarm occurrence are monitored.	60	84
PNU list read	Read the available PNU number.	64	—

NOTE

- Refer to the Instruction Manual (Detailed) of the inverter for functions controllable from the network in each operation mode.

5.2 Input to the inverter from the network

Main items which can be commanded from the network to the inverter and their descriptions are explained below.

Item	Description	Refer to page	
		PPO type support specifications	PPO type non-support specifications
Frequency setting	Set the running frequency of the inverter.	48	83
Operation mode write	Set the operation mode of the inverter.	56	83
Run command	Set the control input command such as forward operation signal (STF) and reverse rotation signal (STR).	47	82
Inverter reset	Reset the inverter.	57	81
Parameter write	Set parameters of the inverter.	45, 65	75, 85
Parameter clear	Return parameters to the initial values.	56	81
Input terminal function	Use the function of the inverter input terminal.	49	82



- Refer to the Instruction Manual (Detailed) of the inverter for functions controllable from the network in each operation mode.

PROFIBUS DEVICE DATA

6.1 Device data (GSD file)

A GSD file is required to connect the inverter (FR-A8NP) to the Profibus network and use Profibus configuration software. The GSD file contains information on the communication setting of the inverter (FR-A8NP).

GSD file can be downloaded from the web site.

Mitsubishi Electric FA Site
www.MitsubishiElectric.co.jp/fa

The download is free.
Contact your sales representative for details.

When editing this file, use a text editor.

For installation instructions, refer to the instruction manual of the PROFIBUS-DP Configuration Software.

Although this product complies with PPO type specification, it includes specifications which do not support PPO type specification (FR-A5NP intercompatibility protocol). This manual states the section supporting PPO type specification as PPO type support specification and the section not supporting PPO type as PPO type non-support specification.



- You cannot use the device data which does not include PPO supporting specification (data for the FR-A5NP).

- Details of the GSD file

Parameter	Value	Description *1
#Profibus_DP		File header
GSD_Revision	1	ID version of GSD file
Vendor_Name	"Mitsubishi Electric"	Manufacturer name *2
Model_Name	"FR-A8NP"	Product name
Revision	—	Product version
Ident_Number	H0EA8	Device number obtained from Profibus Nutzer Organization
Protocol_Ident	0	PROFIBUS-DP is 0 fixed.
Station_Type	0	DP slave is 0 fixed.
FMS_Supp	0	FMS (Field-Bus Message Specifications) not supported.
Hardware_Release	—	Hardware version
Software_Release	—	Software version
9.6_supp	1	Communication speed 9600 bps support
19.2_supp	1	Communication speed 19.2 Kbps support
93.75_supp	1	Communication speed 93.75 Kbps support
187.5_supp	1	Communication speed 187.5 Kbps support
500_supp	1	Communication speed 500 Kbps support
1.5M_supp	1	Communication speed 1.5 Mbps support
3M_supp	1	Communication speed 3.0 Mbps support
6M_supp	1	Communication speed 6.0 Mbps support
12M_supp	1	Communication speed 12.0 Mbps support

Parameter	Value	Description *1
MaxTsdr_9.6	15	Longest time 15 bit times at communication speed 9600 bps
MaxTsdr_19.2	15	Longest time 15 bit times at communication speed 19.2 Kbps
MaxTsdr_93.75	15	Longest time 15 bit times at communication speed 93.75 Kbps
MaxTsdr_187.5	15	Longest time 15 bit times at communication speed 187.5 Kbps
MaxTsdr_500	15	Longest time 15 bit times at communication speed 500 Kbps
MaxTsdr_1.5M	25	Longest time 25 bit times at communication speed 1.5 MKbps
MaxTsdr_3M	50	Longest time 50 bit times at communication speed 3.0 Mbps
MaxTsdr_6M	100	Longest time 100 bit times at communication speed 6.0 Mbps
MaxTsdr_12M	200	Longest time 200 bit times at communication speed 12.0 Mbps
Redundancy	0	Redundancy not supported.
Repeater_Ctrl_Sig	2	Installed as TTL level via RTS signal from module.
24V_Pins	0	24 V power supply for maintenance device connection is not used.
Freeze_Mode_supp	1	Freeze mode supported.
Sync_Mode_supp	1	Synchronous mode supported.
Auto_Baud_supp	1	Automatic baud rate detection support
Set_Slave_Add_supp	0	Slave address is not set.
Min_Slave_Intervall	1	100 μ s interval between 2 polling cycles
Modular_Station	1	Modular device specified.
Max_Module	1	Maximum number of modules:1
Max_Input_Len	28	Input data: Maximum 28 bytes
Max_output_Len	28	Output data: Maximum 28 bytes

Parameter	Value	Description *1
Max_Data_Len	56	Input and output data: Maximum 28 + 28 = 56 bytes
Fail_Safe	0	Failsafe not supported
Max_Diag_Data_Len	6	Diagnostic data of 6 bytes secured (no external diagnosis)
Slave_Family	1	Drives defined as function class (Main Family)
PrmText	1	Text selection 1 registration
Text(0)	"No byte swapping"	If Bit 0 = 0, "No byte swapping"
Text(1)	"Byte swapping"	If Bit 0 = 1, "Byte swapping"
EndPrmText		
ExtUserPrmData	1 "Byte swapping"	Byte swapping selection 1 registration on text base
Bit(0) 0 0-1		Bit 0 = default 0, range 0 to 1
Prm_Text_Ref	1	Text selection 1 is used.
EndExtUserPrmData		
Max_User_Prm_Data_Len	2	User parameter of 2 bytes secured
Ext_User_Prm_Data_Const(0)	H01	Initial value of user parameter's 1 byte
Ext_User_Prm_Data_Const(1)	H00	Initial value of user parameter's 2 byte
Ext_User_Prm_Data_Ref(1)	1	Byte swapping selection 1 is used on text base in user parameter's 2 byte.
Module	"PPO type 1" HF3, HF1	PPO type 1 selection
EndModule		
Module	"PPO type 2" HF3, HF5	PPO type 2 selection
EndModule		
Module	"PPO type 3" HF1	PPO type 3 selection

Parameter	Value	Description *1
EndModule		
Module	"PPO type 4" HF5	PPO type 4 selection
EndModule		
Module	"PPO type 5" HF3, HF9	PPO type 5 selection
EndModule		
Module	"500 series" H75	FR-A5NP intercompatibility protocol selection
EndModule		

*1 Description is not included in the ASCII file itself.

*2 Use "Mitsubishi" if the maximum number of characters of the Vendor-Name of the master used is 10.

6.2 Slave user parameter

By changing the slave user parameter value, you can use the byte swapping function (byte inversion function). Setting "1" at Address H1 (Bit 0) enable the byte swapping function. Since "—" is an unused bit, set "0".

Address	Functions							
H0	For manufacturer setting (Always set "1".)							
H1	Bit 7	Bit 6	Bit 5	Bit 4	Bit 3	Bit 2	Bit 1	Bit 0
	—	—	—	—	—	—	—	0:Byte swapping function disabled 1:Byte swapping function enabled

- Example of when the byte swapping function is disabled (address H1 (Bit 0) = "0")

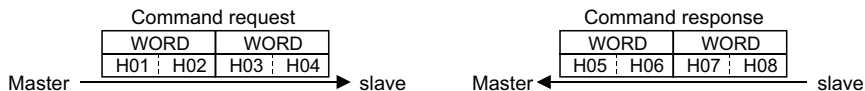

- Example of when the byte swapping function is enabled (address H1 (Bit 0) = "1")

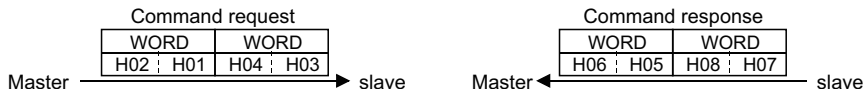

The data is byte swapped in the slave to be a receiving/sending data.

7 PPO TYPE SUPPORT SPECIFICATION

7.1 PROFIBUS profiles

The option unit operates as a "slave of the PROFIBUS DP master" or a "controller equivalent to PROFIBUS DP master class 1 on an RS-485 network".

The PROFIBUS profile (data buffer) can be selected from among six different types, "PPO type1" to "PPO type5", and "A5NP". (For the module type "A5NP" profile, refer to [Chapter 8](#).)

Module type is changed with the slave module setting. For details, refer to the instruction manual of the Network Master Configuration Software. The configuration of PPO type is as follows.

7.1.1 Setting the PROFIBUS format (Pr.1110)

For the FR-A800 series, set the Profibus format in the **Pr.1110 PROFIBUS format selection**. (For the FR-F800 series, only the standard format can be used.)

Set **Pr.1110** = "1" to extend the PPO type 2 and PPO type 5 PROFIBUS profile formats. Then, commands and monitor items can be assigned to Word 8 to Word 10 in PPO type 2, and Word 8 to Word 14 in PPO type 5. (The format is not extended for PPO type 1, PPO type 3, and PPO type 4.)

Pr.	Name	Initial value	Setting range	Function
1110*1	PROFIBUS format selection	0	0	Standard format
			1	Extended format

*1 The setting is available only for the FR-A800 series.

◆ Standard format (Pr.1110 = "0" (initial value))

The following shows the configuration of the PPO type in the standard format.

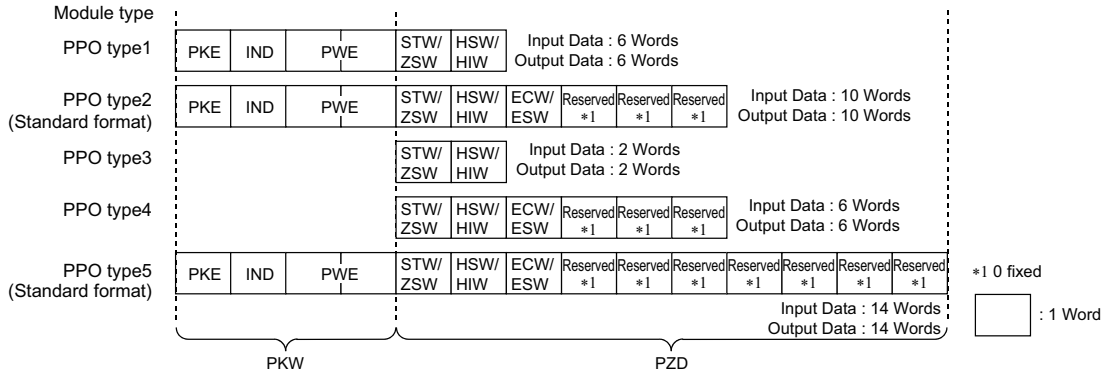

◆ Extended format (Pr.1110 = "1" (only for the FR-A800 series))

Set **Pr.1110 PROFIBUS format selection** = "1" (extended format) to extend the format of PPO type 2 and PPO type 5. Then, REF1/STS1 to REF7/STS7 are available.

The format for PPO type 1, PPO type 3, and PPO type 4 remains the standard format.

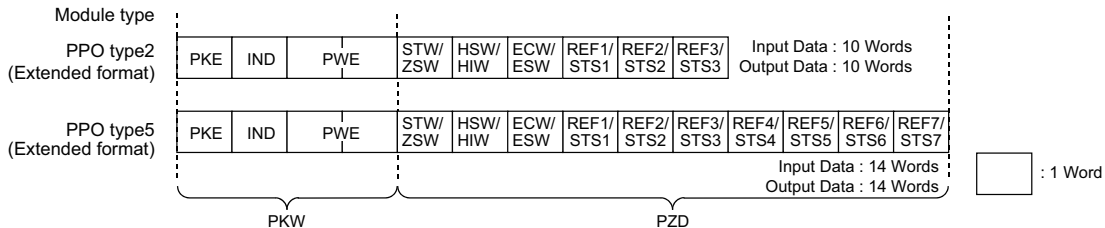

7.2 ID definitions

ID		Definition
PKW (Refer to page 45)	PKE	PNU number (PNU) and task or response Id (AK)
	IND	Sub-Index number and Ext-Index number
	PWE	Set 0 since high bits (Bits 16 to 31) are not used. Low bits (Bits 0 to 15): Parameter value
PZD (Refer to page 47)	STW/ZSW	STW: Control Word (command request) *1
		ZSW: Status Word (command response) *1
	HSW/HIW	HSW: Set frequency (command request) *1
		HIW: Output frequency (command response) *1
	ECW/ESW	ECW: Extended Control Word (command request) *1
		ESW: Extended Status Word (command response) *1
	REF1 to REF7/ STS1 to STS7	REF1 to REF7: Command setting (Command request in the extended format) *1
STS1 to STS7: Arbitrarily set monitor item (Command response in the extended format) *1		
Reserved	Reserved area for extension	

- *1 Command request: Message from the master to the slave
Command response: Message from the slave to the master

7.3 Buffer memory configuration

The buffer memory configuration is shown below.

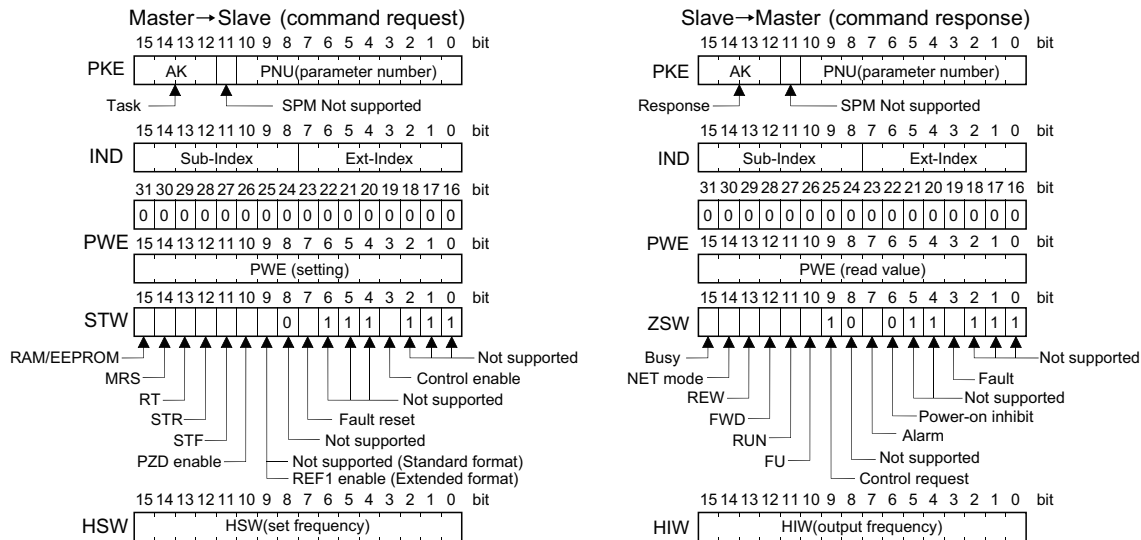

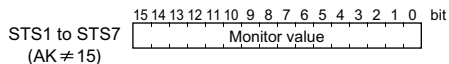
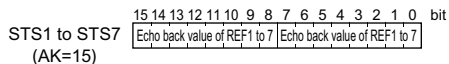
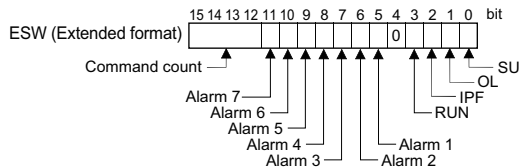
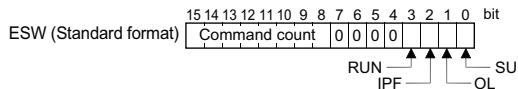
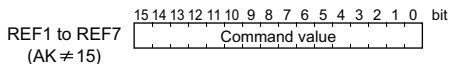
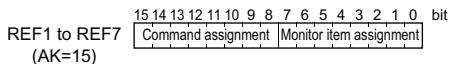
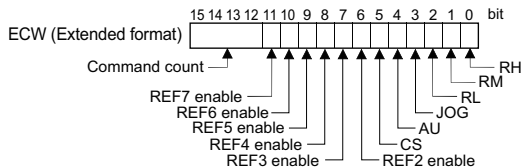
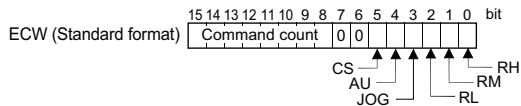

7.4 Buffer memory details

The following indicates the buffer memory details of the Profibus profiles.

◆ PKW

Name		Bit	Definition																	
PKE	PNU	0 to 10	PNU number																	
	SPM	11	Not used (0 is set)																	
	AK	12 to 15	[Command request]																	
			<table border="1"> <thead> <tr> <th>Value</th> <th>Operation</th> </tr> </thead> <tbody> <tr> <td>0</td> <td>No task</td> </tr> <tr> <td>1</td> <td>Parameter value is requested (read request)</td> </tr> <tr> <td>2</td> <td>Parameter value (word) is changed (write request)</td> </tr> <tr> <td>6</td> <td>Parameter value (array) is requested (read request)</td> </tr> <tr> <td>7</td> <td>Parameter value (array word) is changed (write request)</td> </tr> <tr> <td>15 *1</td> <td>Batch setting of commands and monitor items (write request)</td> </tr> <tr> <td>Other than the above</td> <td>Not supported</td> </tr> </tbody> </table>		Value	Operation	0	No task	1	Parameter value is requested (read request)	2	Parameter value (word) is changed (write request)	6	Parameter value (array) is requested (read request)	7	Parameter value (array word) is changed (write request)	15 *1	Batch setting of commands and monitor items (write request)	Other than the above	Not supported
			Value	Operation																
			0	No task																
			1	Parameter value is requested (read request)																
			2	Parameter value (word) is changed (write request)																
			6	Parameter value (array) is requested (read request)																
			7	Parameter value (array word) is changed (write request)																
15 *1			Batch setting of commands and monitor items (write request)																	
Other than the above			Not supported																	
[Command response]																				
<table border="1"> <thead> <tr> <th>Value</th> <th>Operation</th> </tr> </thead> <tbody> <tr> <td>0</td> <td>No response (Busy status)</td> </tr> <tr> <td>1</td> <td>Parameter value (word) is transferred.</td> </tr> <tr> <td>4</td> <td>Parameter value (array word) is transferred.</td> </tr> <tr> <td>7</td> <td>Command execution error (error number is stored into PWE)</td> </tr> <tr> <td>15 *1</td> <td>Batch setting of commands and monitor items is completed.</td> </tr> <tr> <td>Other than the above</td> <td>Not supported</td> </tr> </tbody> </table>		Value	Operation	0	No response (Busy status)	1	Parameter value (word) is transferred.	4	Parameter value (array word) is transferred.	7	Command execution error (error number is stored into PWE)	15 *1	Batch setting of commands and monitor items is completed.	Other than the above	Not supported					
Value	Operation																			
0	No response (Busy status)																			
1	Parameter value (word) is transferred.																			
4	Parameter value (array word) is transferred.																			
7	Command execution error (error number is stored into PWE)																			
15 *1	Batch setting of commands and monitor items is completed.																			
Other than the above	Not supported																			

Name	Bit	Definition																
IND	0 to 7	Ext-Index number When Bit 0 (extended parameter access) = "1" and AK = "1 or 2", the PNU value (parameter number) plus 1000 can be read or written.																
	8 to 15	Sub-Index number At command request, set this number when AK ="6, 7".																
PWE	0 to 15	PNU read value/write value When command response AK ="7" (command execution error), PWE definition is as follows.																
		<table border="1"> <thead> <tr> <th>Value</th> <th>Error definition</th> </tr> </thead> <tbody> <tr> <td>0</td> <td>Invalid PNU</td> </tr> <tr> <td>1</td> <td>Parameter value unchangeable (This error also occurs when Pr.77="1")</td> </tr> <tr> <td>2</td> <td>Outside setting range</td> </tr> <tr> <td>3</td> <td>Invalid Sub-Index number</td> </tr> <tr> <td>4</td> <td>Without array</td> </tr> <tr> <td>11</td> <td>No parameter change right</td> </tr> <tr> <td>18</td> <td>Other error *2</td> </tr> </tbody> </table>	Value	Error definition	0	Invalid PNU	1	Parameter value unchangeable (This error also occurs when Pr.77 ="1")	2	Outside setting range	3	Invalid Sub-Index number	4	Without array	11	No parameter change right	18	Other error *2
		Value	Error definition															
		0	Invalid PNU															
		1	Parameter value unchangeable (This error also occurs when Pr.77 ="1")															
		2	Outside setting range															
		3	Invalid Sub-Index number															
	4	Without array																
11	No parameter change right																	
18	Other error *2																	
16 to 31	Not used (0 is set)																	

*1 Valid only for the FR-A800 series when **Pr.1110 PROFIBUS format selection** = "1" (extended format). (Refer to [page 40](#))

*2 Indicates outside AK number range, write data error, external operation error, without option error, instruction code error, with STF/STR error, with operation mode specification error, parameter calibration error (**Pr.900** or later), reset disabled error (with reset input specification of **Pr.75**), etc.

◆ PZD

	Name	Bit	Definition	
STW	—	0 to 2	Not used (1 is set)	
	Control enable	3	0: Inverter output shutoff, 1: Inverter output shutoff is cancelled	
	—	4 to 6	Not used (1 is set)	
	Fault reset (Reset)	7	[At inverter error] 0: No action 1: Fault reset (Reset). The operation depends on the Pr.349 setting. (Refer to page 31) [When inverter is normal] No action	
	—	8	Not used (0 is set)	
	— (Standard format)	9	Not used (0 is set)	
	REF1 enable *1 (Extended format)	9	0: REF1 disabled, 1: REF1 enabled (The REF1 setting is applied to the inverter.)	
	PZD enable	10	0: Command request of PZD is not processed.*2 1: Command request of PZD is processed. At power-on or inverter reset, set 1 once.	
	STF signal	11	0: OFF, 1: ON (forward rotation command)	
	STR signal	12	0: OFF, 1: ON (reverse rotation command)	
	Terminal RT function	13	Second function selection *5	The function assigned to the terminal RT is activated.
	MRS signal	14	0: OFF, 1: ON (output is shut off)	
RAM/EEPROM	15	0: Set frequency (HSW) is written to RAM (Power-on reset returns the changed set frequency to the setting before it was written to RAM.). 1: Set frequency (HSW) is written to EEPROM.		

Name		Bit	Definition
ZSW	—	0 to 2	Not used (1 is returned)
	Fault	3	0: Inverter normal 1: Inverter alarm occurrence
	—	4, 5	Not used (1 is returned)
	Power-on inhibit	6	0 is returned
	Alarm	7	Command execution normal Command execution error
	—	8	Not used (0 is returned)
	Control request	9	1 is returned
	FU signal	10	0: OFF 1: ON (output frequency being detected) (Refer to Pr.42 and Pr.43 in the Instruction Manual (Detailed) of the inverter.)
	RUN signal	11	0: OFF 1: ON (inverter running)
	FWD	12	0: Other than forward running (during stop, reverse running) 1: Forward running
	REW	13	0: Other than reverse running (during stop, forward running) 1: Reverse running
	NET mode	14	0: Other than network operation mode 1: Network operation mode
	BUSY	15	0: Ready status 1: Busy status *3
HSW		0 to 15	Set frequency (0.01 Hz increments)
HIW		0 to 15	Output frequency (0.01 Hz increments) *4

Name		Bit	Definition	
ECW (Standard format)	Terminal RH function	0	High speed operation command *5	Functions assigned to terminal RH, RM, RL, JOG, AU and CS are activated.
	Terminal RM function	1	Middle-speed operation command *5	
	Terminal RL function	2	Low-speed operation command *5	
	Terminal JOG function	3	Jog operation command *5	
	Terminal AU function	4	Current input selection *5	
	Terminal CS function	5	Selection of automatic restart after instantaneous power failure *5, *6	
	—	6, 7	Not used (0 is set)	
	Command count	8 to 15	Used by the master to recognize the command response.	

Name		Bit	Definition	
ECW *1 (Extended format)	Terminal RH function	0	High speed operation command *5	Functions assigned to terminal RH, RM, RL, JOG, AU and CS are activated.
	Terminal RM function	1	Middle-speed operation command *5	
	Terminal RL function	2	Low-speed operation command *5	
	Terminal JOG function	3	Jog operation command *5	
	Terminal AU function	4	Current input selection *5	
	Terminal CS function	5	Selection of automatic restart after instantaneous power failure *5, *6	
	REF2 enable	6	0: REF2 disabled, 1: REF2 enabled (The REF2 setting is applied to the inverter.)	
	REF3 enable	7	0: REF3 disabled, 1: REF3 enabled (The REF3 setting is applied to the inverter.)	
	REF4 enable	8	0: REF4 disabled, 1: REF4 enabled (The REF4 setting is applied to the inverter.)	
	REF5 enable	9	0: REF5 disabled, 1: REF5 enabled (The REF5 setting is applied to the inverter.)	
	REF6 enable	10	0: REF6 disabled, 1: REF6 enabled (The REF6 setting is applied to the inverter.)	
	REF7 enable	11	0: REF7 disabled, 1: REF7 enabled (The REF7 setting is applied to the inverter.)	
	Command count	12 to 15	Used by the master to recognize the command response.	
ESW (Standard format)	SU signal	0	0: OFF, 1: ON (up to frequency)	
	OL signal	1	0: OFF, 1: ON (overload alarm)	
	IPF signal	2	0: OFF, 1: ON (an instantaneous power failure or undervoltage occurs)	
	Terminal RUN function	3	Inverter running *7	The function assigned to the terminal RUN is activated.
	—	4 to 7	Not used (0 is set)	
	Command count	8 to 15	Echo back of the command request.	

Name		Bit	Definition	
ESW *1 (Extended format)	SU signal	0	0: OFF, 1: ON (up to frequency)	
	OL signal	1	0: OFF, 1: ON (overload alarm)	
	IPF signal	2	0: OFF, 1: ON (an instantaneous power failure or undervoltage occurs)	
	Terminal RUN function	3	Inverter running *7	The function assigned to the terminal RUN is activated.
	—	4	Not used (0 is set)	
	Alarm 1	5	0: REF1 command execution normal, 1: REF1 command execution error (outside setting range)	
	Alarm 2	6	0: REF2 command execution normal, 1: REF2 command execution error (outside setting range)	
	Alarm 3	7	0: REF3 command execution normal, 1: REF3 command execution error (outside setting range)	
	Alarm 4	8	0: REF4 command execution normal, 1: REF4 command execution error (outside setting range)	
	Alarm 5	9	0: REF5 command execution normal, 1: REF5 command execution error (outside setting range)	
	Alarm 6	10	0: REF6 command execution normal, 1: REF6 command execution error (outside setting range)	
	Alarm 7	11	0: REF7 command execution normal, 1: REF7 command execution error (outside setting range)	
	Command count	12 to 15	Echo back of the command request.	

Name		Bit	Definition
REF1 to REF7 (when AK = "15")	Monitor item assignment to STS1 to STS7	0 to 7	Function number of the monitor item assigned to STS1 to STS7 (Refer to page 59)
	Command assignment to REF1 to REF7	8 to 15	Function number of the command assigned to REF1 to REF7 (Refer to page 57)
STS1 to STS7 (when AK = "15")	Monitor item assignment to STS1 to STS7	0 to 7	Echo back value of Bits 0 to 7 (STS monitor item assignment) of REF1 to REF7
	Command assignment to REF1 to REF7	8 to 15	Echo back value of Bits 8 to 15 (REF command assignment) of REF1 to REF7
REF1 to REF7 (when AK ≠ "15")	Command value of REF1 to REF7	0 to 15	Command value of the function assigned to Bits 8 to 15 (REF command assignment) of REF1 to REF7 when AK = "15"
STS1 to STS7 (when AK ≠ "15")	Monitor value of STS1 to STS7	0 to 15	Monitor value of the item assigned to Bits 0 to 7 (STS monitor item assignment) of REF1 to REF7 when AK = "15"

- *1 Valid only for the FR-A800 series when **Pr.1110 PROFIBUS format selection** = "1" (extended format). (Refer to [page 40](#))
- *2 PZD enable and command count request can be executed.
- *3 If it takes time to perform slave side processing, slave side busy status is announced since reply to the master will be delayed. During busy status, other response data are unfixed values. When the slave side is busy, request from the master is invalid. Therefore, the same request must be sent again. The response data of the FR-A8NP during Busy status is as follows.

ID	During busy status and inverter reset	During busy status and other than inverter rest
PKW	0	All 0 when AK="0" Reply data when AB≠"0"
PZD	ZSW Bit 15 (BUSY) ="1" Other error Bit="0"	ZSW Bit 15 (BUSY) ="1" Other error Bit=inverter status data

- *4 When a value other than 9999 is set in **Pr.430 Pulse monitor selection** under position control (**Pr.800**="3, 4") for the FR-A800 series, pulse monitor is selected. (Refer to the Instruction Manual (Detailed) of the inverter for pulse monitor.)
- *5 Signal names are initial values. Using **Pr.180 to Pr.186**, you can change output signal functions. Refer to the Instruction Manual (Detailed) of the inverter for details of **Pr.180 to Pr.186**.
- *6 For the FR-F800 series, no function is assigned in the initial setting.
- *7 These signals are set in the initial setting. Using **Pr.190**, output signal assigned to the device number can be changed. For the details of **Pr.190**, refer to the Instruction Manual (Detailed) of the inverter.

NOTE

- Only when the contents of the command request (request for changing the inverter setting: PKW, HSW, STW/ECW) from the master changed, the inverter processes the request. If the contents of the command request are identical with those of the last request, the inverter does not process the request. (The received request is cleared.)
For instance, while the master keeps sending the "network operation mode enable" command, changing the mode to the PU operation mode with switchover function does not allow the "network operation mode enable" command to be executed due to the same contents as that sent last time. Therefore, the operation mode remains the PU operation mode without changing to the Network operation mode. In this case, send another command as "PU operation mode enable" from the master once, then send the "network operation mode enable" command again.

7.5 Outline of PNU

You can use the PNU to make inverter settings from the network.

The data used with the network is denoted PNU (P) to differentiate it from the parameter (Pr.) of the inverter.

This chapter explains the module type "PPO type 1" to "PPO type 5".



- Parameter definitions differ according to the module type selected. When using "A5NP", refer to [page 79](#).

◆ PNU data definition

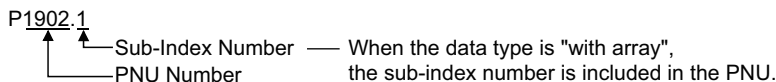

◆ PNU data type

The PNU has the data types of "Array Unsigned 16" and "Unsigned 16".

Data type	Array	Example
Array Unsigned 16 (AUs16)	With	P1902.1 ↑ Sub-Index Number
Unsigned 16 (Us16)	Without	P1240



- When the data type is "with array", include the sub-index number in the PNU.

7.6 PROFIBUS PNU

7.6.1 Real-time monitor

Different inverter data can be monitored using the master.

The data type for each monitor item is AUs16. The PNU number for the real-time monitor is 1.

The monitored item and the sub-index number are the same as those of the RS-485 communication dedicated monitor of the inverter.

For the details of the monitor items, refer to the monitor display section in the Instruction Manual (Detailed) of the inverter.

PNU	Item	Increments
P1.1	Output frequency	0.01 Hz
P1.2	Output current	0.01 A/0.1 A
P1.3	Output voltage	0.1 V
.	.	.
.	.	.
.	.	.

7.6.2 Parameter clear

Parameter clear can be performed from the master.

PNU	Item	Data definition	Data type
P2.2	Parameter clear	H965A	AUs16
P2.3	All parameter clear	H99AA	AUs16
P2.5	Parameter clear *1	H5A96	AUs16
P2.6	All parameter clear *1	HAA99	AUs16
P2.8	Faults history clear	H0000	AUs16

*1 The communication parameters are not cleared. For details of the communication parameters, refer to the Instruction Manual (Detailed) of the inverter.

7.6.3 Operation mode read/write

Read/write of the operation mode can be performed from the master.

PNU	Item	Data definition	Data type
P3	Operation mode read/write	External operation mode: H10 PU operation mode: H11 (For writing, when "6" is set in Pr.79) Network operation mode: H14	Us16

7.6.4 Set frequency read

The frequency set to the inverter can be read from the master.

PNU	Item	Data definition	Data type
P4.1	Set frequency (RAM) read	Set frequency (RAM) is read.	AUs16
P4.2	Set frequency (EEPROM) read	Set frequency (EEPROM) is read.	AUs16

7.6.5 Terminal input read

Analog input values of terminals 2, 4, and 1 can be read.

PNU	Item	Data definition	Data type
P5.1	Terminal 2 input value read	Terminal 2 input value (%) is read.	AUs16
P5.2	Terminal 4 input value read	Terminal 4 input value (%) is read.	AUs16
P5.3	Terminal 1 input value read	Terminal 1 input value (%) is read.	AUs16

7.6.6 Inverter reset

The inverter can be reset from the master.

PNU	Item	Data definition	Data type
P6	Inverter reset	The inverter is reset after the data was written from the master.	Us16

- The inverter maintains the resetting status while reset is requested.
- When **Pr.75 Reset selection/disconnected PU detection/PU stop selection** = "1, 3, 15, 17, 101, 103, 115, 117", reset is enabled only during an inverter error.

7.6.7 REF command assignment (available only when the extended format is selected) (only for the FR-A800 series)

When AK = "15", commands can be assigned to Bits 8 to 15 of REF1 to REF7. Command value for the assigned command can be given in REF1 to REF7 when AK ≠ "15".

PNU	Item	Data type
P10.1	REF1 command assignment	Aus16
P10.2	REF2 command assignment	Aus16
P10.3	REF3 command assignment	Aus16
P10.4	REF4 command assignment	Aus16
P10.5	REF5 command assignment	Aus16
P10.6	REF6 command assignment	Aus16
P10.7	REF7 command assignment	Aus16

- For details of the commands (settings) which can be assigned to REF1 to REF7, refer to the following table.

Setting value	Description	Resolution of the setting	Unit	Condition to enable a command given by the master via the Profibus communication	Refer to page
0	No function	—	—	—	—
1	Torque command (under torque control)	1/0.01	%	When Pr.804 Torque command source selection = "3 or 5"	69
	Torque limit (under speed control)			When a command (setting value) is assigned to REF1 to REF7 under speed control, and a write command of the setting value is received	—
2	Magnetic flux command (0 to 200%)	1	%	When Pr.1109 PROFIBUS communication command source selection = "0001" (This setting is valid under vector control only.)	68
3	Torque bias	0.01	%	When Pr.840 Torque bias selection = "24 or 25"	70
4	Speed control P gain (%)	1	%	When Pr.1109 = "0010"	68
	Speed control P gain (per-unit system)	0.01	%	When Pr.1109 = "0020" (The per-unit system is applied regardless of the settings in Pr.1117 Speed control P gain 1 (per-unit system) and Pr.1118 Speed control P gain 2 (per-unit system) .)	68
5	Speed control integral time	0.001	s	When Pr.1109 = "0100"	68
6	Droop gain	0.1	%	When Pr.1109 = "1000"	68

- Writing of a setting value is performed while the write command is ON.
- When the setting via the Profibus communication is enabled, the values set via communication are valid even when disconnection occurs or "0" is set as a command (setting value) in REF1 to REF7.
(However, when the **Pr.805 Torque command value (RAM)** setting is changed, the torque command value (torque limit value) will be changed accordingly.)

7.6.8 STS monitor function (available only when the extended format is selected) (only for the FR-A800 series)

When AK = "15", monitor numbers can be assigned to Bits 0 to 7 of REF1 to REF7. Assigned items can be monitored in STS1 to STS7 when AK ≠ "15".

The monitored item and the monitor number are the same as those of the RS-485 communication dedicated monitor of the inverter.

(Refer to the Instruction Manual (Detailed) of the inverter.)

PNU	Item	Data type
P11.1	STS1 monitor value	Aus16
P11.2	STS2 monitor value	Aus16
P11.3	STS3 monitor value	Aus16
P11.4	STS4 monitor value	Aus16
P11.5	STS5 monitor value	Aus16
P11.6	STS6 monitor value	Aus16
P11.7	STS7 monitor value	Aus16

7.6.9 Node address read

The node address of the inverter can be read.

PNU	Item	Data definition	Data type
P918	Node address read	The node address settings of the inverter are read.	Us16

7.6.10 Faults history read

- Fault records of past eight faults occurred in the inverter can be read.
(For the data codes or details of fault records, refer to the Instruction Manual (Detailed) of the inverter.)

PNU	Item	Data definition		Data type
P947.1 to P947.8	Latest fault is read	P947.1	Data code of the fault record	AUs16
		P947.2 to P947.8	All 0	
P947.9 to P947.16	Second fault in past is read	P947.9	Data code of the fault record	AUs16
		P947.10 to P947.16	All 0	
P947.17 to P947.24	Third fault in past is read	P947.17	Data code of the fault record	AUs16
		P947.18 to P947.24	All 0	
P947.25 to P947.32	Forth fault in past is read	P947.25	Data code of the fault record	AUs16
		P947.26 to P947.32	All 0	
P947.33 to P947.40	Fifth fault in past is read	P947.33	Data code of the fault record	AUs16
		P947.34 to P947.40	All 0	
P947.41 to P947.48	Sixth fault in past is read	P947.41	Data code of the fault record	AUs16
		P947.42 to P947.48	All 0	
P947.49 to P947.56	Seventh fault in past is read	P947.49	Data code of the fault record	AUs16
		P947.50 to P947.56	All 0	
P947.57 to P947.64	Eighth fault in past is read	P947.57	Data code of the fault record	AUs16
		P947.58 to P947.64	All 0	

- Energization time (fault monitor) for past eight alarms at the inverter alarm occurrence can be read.

PNU	Item	Data definition		Data type
P948.1 to P948.8	Latest fault monitor energization time read	P948.1	Energization time	AU _s 16
		P948.2 to P948.8	All 0	
P948.9 to P948.16	Energization time of second fault monitor in past read	P948.9	Energization time	AU _s 16
		P948.10 to P948.16	All 0	
P948.17 to P948.24	Energization time of third fault monitor in past read	P948.17	Energization time	AU _s 16
		P948.18 to P948.24	All 0	
P948.25 to P948.32	Energization time of forth fault monitor in past read	P948.25	Energization time	AU _s 16
		P948.26 to P948.32	All 0	
P948.33 to P948.40	Energization time of fifth fault monitor in past read	P948.33	Energization time	AU _s 16
		P948.34 to P948.40	All 0	
P948.41 to P948.48	Energization time of sixth fault monitor in past read	P948.41	Energization time	AU _s 16
		P948.42 to P948.48	All 0	
P948.49 to P948.56	Energization time of seventh fault monitor in past read	P948.49	Energization time	AU _s 16
		P948.50 to P948.56	All 0	
P948.57 to P948.64	Energization time of eighth fault monitor in past read	P948.57	Energization time	AU _s 16
		P948.58 to P948.64	All 0	

- Output frequency, output current and output voltage for past eight alarms at the inverter alarm occurrence can be read.

PNU	Item	Data definition		Data type
P949.1 to P949.8	Latest fault monitor frequency, current and voltage read	P949.1	Output frequency	AUs16
		P949.2	Output current	
		P949.3	Output voltage	
		P949.4 to P949.8	All 0	
P949.9 to P949.16	Second fault monitor frequency, current and voltage in past read	P949.9	Output frequency	AUs16
		P949.10	Output current	
		P949.11	Output voltage	
		P949.12 to P949.16	All 0	
P949.17 to P949.24	Third fault monitor frequency, current and voltage in past read	P949.17	Output frequency	AUs16
		P949.18	Output current	
		P949.19	Output voltage	
		P949.20 to P949.24	All 0	
P949.25 to P949.32	Forth fault monitor frequency, current and voltage in past read	P949.25	Output frequency	AUs16
		P949.26	Output current	
		P949.27	Output voltage	
		P949.28 to P949.32	All 0	
P949.33 to P949.40	Fifth fault monitor frequency, current and voltage in past read	P949.33	Output frequency	AUs16
		P949.34	Output current	
		P949.35	Output voltage	
		P949.36 to P949.40	All 0	

PNU	Item	Data definition		Data type
P949.41 to P949.48	Sixth fault monitor frequency, current and voltage in past read	P949.41	Output frequency	AUs16
		P949.42	Output current	
		P949.43	Output voltage	
		P949.44 to P949.48	All 0	
P949.49 to P949.56	Seventh fault monitor frequency, current and voltage in past read	P949.49	Output frequency	AUs16
		P949.50	Output current	
		P949.51	Output voltage	
		P949.52 to P949.56	All 0	
P949.57 to P949.64	Eighth fault monitor frequency, current and voltage in past read	P949.57	Output frequency	AUs16
		P949.58	Output current	
		P949.59	Output voltage	
		P949.60 to P949.64	All 0	

7.6.11 PNU list read

The usable PNU numbers can be read.

PNU	Item	Data definition	Data type
P980.1 to 116 P981.1 to 116 P982.1 to 116 P983.1 to 116 P984.1 to 116 P985.1 to 116 P986.1 to 116 P987.1 to 116 P988.1 to 116 P989.1 to 116	PNU list read	Usable PNU numbers are read in sorted status.	AUs16

- PNU list read example

PNU	Usable PNU number	Remarks
P980.1	1	Inverter command parameter
P980.2	2	
P980.3	3	
⋮	⋮	
P980.23	1000	Inverter standard parameter
P980.24	1001	
P980.25	1002	
⋮	⋮	
⋮	0*1	

*1 When 0 is stored, read is terminated.

7.7 Standard parameters

You can use the PNU to make parameter settings from the network.

The table below lists PNU numbers corresponding to parameter numbers.

Standard parameter examples are introduced below. Refer to the examples and make parameter settings.

The usable parameters depend on the inverter. Refer to the Instruction Manual (Detailed) of the inverter for details of the parameters.

Representation of the PNU for standard parameters (Example: **Pr.902**)

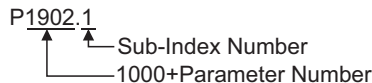

- Example of parameter list

PNU	Name		Data type
	Bit 0 of the ext-index number = "0"	Bit 0 of the ext-index number = "1"	
P1000	Pr.0 Torque boost	Pr.1000	Us16
P1001	Pr.1 Maximum frequency	Pr.1001	Us16
P1002	Pr.2 Minimum frequency	Pr.1002 Lq tuning target current adjustment coefficient	Us16
P1003	Pr.3 Base frequency	Pr.1003 Notch filter frequency	Us16
P1004	Pr.4 Multi-speed setting (high speed)	Pr.1004 Notch filter depth	Us16
P1005	Pr.5 Multi-speed setting (middle speed)	Pr.1005 Notch filter width	Us16
P1006	Pr.6 Multi-speed setting (low speed)	Pr.1006 Clock (year)	Us16
⋮	⋮	⋮	⋮



- Write to **Pr.77** and **Pr.79** is not allowed from the network with FR-A8NP. (Read is allowed.)
- To read or write parameter of **Pr.1000** or later, set Bit 0 of the ext-index number (extended parameter access) = "1". (Refer to [page 46](#))

The following parameters require the sub-index number for the PNU.

Pr.	PNU	Name	Data Type
C0 (900)	P1900.1	FM/CA terminal calibration	AUs16
C1 (901)	P1901.1	AM terminal calibration	AUs16
C2 (902)	P1902.1	Terminal 2 frequency setting bias frequency	AUs16
C3 (902)	P1902.2	Terminal 2 frequency setting bias	AUs16
125 (903)	P1903.1	Terminal 2 frequency setting gain frequency	AUs16
C4 (903)	P1903.2	Terminal 2 frequency setting gain	AUs16
C5 (904)	P1904.1	Terminal 4 frequency setting bias frequency	AUs16
C6 (904)	P1904.2	Terminal 4 frequency setting bias	AUs16
126 (905)	P1905.1	Terminal 4 frequency setting gain frequency	AUs16
C7 (905)	P1905.2	Terminal 4 frequency setting gain	AUs16
C12 (917)	P1917.1	Terminal 1 bias frequency (speed)	AUs16
C13 (917)	P1917.2	Terminal 1 bias (speed)	AUs16
C14 (918)	P1918.1	Terminal 1 gain frequency (speed)	AUs16
C15 (918)	P1918.2	Terminal 1 gain (speed)	AUs16
C16 (919)	P1919.1	Terminal 1 bias command (torque)	AUs16
C17 (919)	P1919.2	Terminal 1 bias (torque)	AUs16
C18 (920)	P1920.1	Terminal 1 gain command (torque)	AUs16
C19 (920)	P1920.2	Terminal 1 gain (torque)	AUs16
C8 (930)	P1930.1	Current output bias signal	AUs16

Pr.	PNU	Name	Data Type
C9 (930)	P1930.2	Current output bias current	AUs16
C10 (931)	P1931.1	Current output gain signal	AUs16
C11 (931)	P1931.2	Current output gain current	AUs16
C38 (932)	P1932.1	Terminal 4 bias command (torque)	AUs16
C39 (932)	P1932.2	Terminal 4 bias (torque)	AUs16
C40 (933)	P1933.1	Terminal 4 gain command (torque)	AUs16
C41 (933)	P1933.2	Terminal 4 gain (torque)	AUs16
C42 (934)	P1934.1	PID display bias coefficient	AUs16
C43 (934)	P1934.2	PID display bias analog value	AUs16
C44 (935)	P1935.1	PID display gain coefficient	AUs16
C45 (935)	P1935.2	PID display gain analog value	AUs16

7.8 PROFIBUS-DP communication function setting

7.8.1 PROFIBUS communication command source setting (Pr.1109) (only for the FR-A800 series)

Use **Pr.1109 PROFIBUS communication command source selection** to set the input source for the magnetic flux command, speed control P gain, speed control integral time, and droop gain in the buffer memory REF1 to REF7 in the extended format of the PROFIBUS profiles, PPO type 2 and PPO type 5.

For the details of the setting of **Pr.1109**, refer to the following table.

Selectable function	Pr.1109 setting	Description
Magnetic flux command input source selection	0000 (initial value)	Input the magnetic flux command from external analog terminals (terminals 1 and 4).
	0001	Set the magnetic flux command in REF1 to REF7.
Speed control P gain input source selection	0000 (initial value)	Settings in Pr.820 Speed control P gain 1 and Pr.830 Speed control P gain 2 are valid.
	0010	Set the speed control P gain in REF1 to REF7.
	0020	Set the speed control P gain in REF1 to REF7 (per-unit system)
Speed control integral time input source selection	0000 (initial value)	Settings in Pr.821 Speed control integral time 1 and Pr.831 Speed control integral time 2 are valid.
	0100	Set the speed control integral time in REF1 to REF7.
Droop gain input source selection	0000 (initial value)	Setting in Pr.286 Droop gain is valid.
	1000	Set the droop gain in REF1 to REF7.

7.8.2 Torque command / torque limit via PROFIBUS communication (Pr.804) (only for the FR-A800 series)

Setting **Pr.804 Torque command source selection** = "3 or 5" enables torque command / torque limit via PROFIBUS communication under Real sensorless vector control, torque control under vector control, and speed control.
 (When **Pr.804** ≠ "3 or 5", writing a torque command/limit value via PROFIBUS communication causes turning ON of Alarm 1 to Alarm 7 corresponding to REF1 to REF7, resulting in generation of a command execution error.)

Pr.	Name	Initial value	Setting Range	Torque command (used under torque control)	Torque limit (used under speed control)*2
804	Torque command source selection	0	0	Torque command by terminal 1 analog input	Input via PROFIBUS communication is not available.
			1	Torque command by the parameter setting (Pr.805 or Pr.806) (-400% to 400%)*1	
			3	Torque command via PROFIBUS communication (FR-A8NP) • Torque command by the parameter setting (Pr.805 or Pr.806) (-400% to 400%)*1 • Setting is available in the buffer memory REF1 to REF7 (-400% to 400%)	Input via PROFIBUS communication is available. (Regardless of the priority of the torque limit value input*3)
			4	16-bit digital input (FR-A8AX)	Input via PROFIBUS communication is not available.
			5	Torque command via PROFIBUS communication (FR-A8NP) • Torque command by the parameter setting (Pr.805 or Pr.806) (-327.68% to 327.67%)*1 • Setting is available in the buffer memory REF1 to REF7 (-327.68% to 327.67%)	Input via PROFIBUS communication is available. (Regardless of the priority of the torque limit value input*3)
			6	Torque command by the parameter setting (Pr.805 or Pr.806) (-327.68% to 327.67%)*1	Input via PROFIBUS communication is not available.

*1 Can also be set from operation panel or parameter unit.

*2 When used as a torque limit value, the value is an absolute value.

*3 The priority of the torque limit value is as follows: TL signal > PROFIBUS communication > **Pr.810**.

7.8.3 Torque bias selection (Pr.840) (only for the FR-A800 series)

Under speed control under vector control, setting **Pr.840 Torque bias selection** = "24 or 25" enables torque bias setting via PROFIBUS communication.

Pr.	Name	Initial value	Setting range	Description
840	Torque bias selection	9999	0	Set the torque bias amount using contact signals (X42, X43) in Pr.841 to Pr.843 .
			1	Set the torque bias amount using terminal 1 in any of C16 to C19 . (When the squirrel cage rises during forward motor rotation.)
			2	Set the torque bias amount using terminal 1 in any of C16 to C19 . (When the squirrel cage rises during reverse motor rotation.)
			3	The torque bias amount using terminal 1 can be set automatically in C16 to C19 and Pr.846 according to the load.
			24	Torque bias command in the PROFIBUS buffer memory REF1 to REF7 Setting range: 600 to 1400 (-400% to 400%)
			25	Torque bias command in the PROFIBUS buffer memory REF1 to REF7 Setting range: -32768 to 32767 (-327.68% to 327.67%)
			9999	No torque bias, rated torque 100%

7.8.4 Frequency command with sign (Pr.541)

By adding a sign to the frequency command value or the speed limit value, the start command (forward/reverse rotation) can be inverted to start operation.

Select whether or not to use a sign for the frequency command value / speed limit value.

Pr.	Name	Initial value	Setting range
541	Frequency command sign selection	0	0, 1

Rotations per minute (mechanical speed) setting using Pr.37 and Pr.144	Pr.541 setting value	Sign	Setting range	Actual frequency command
Not used	0	Not used	0 to 59000	0 to 590.00 Hz
	1	Used	-32768 to 32767 (complement of 2)	-327.68 to 327.67 Hz
Used	0	Not used	0 to 65535	Differs according to the Pr.37, Pr.144 and Pr.811 settings. (in 1 or 0.1 increments)
	1	Used	-32768 to 32767 (complement of 2)	

- Relationship between the start command and sign (Pr.541 = "1")

Start command	Sign of the frequency command	Actual operation command
Forward rotation	+	Forward rotation
	-	Reverse rotation
Reverse rotation	+	Reverse rotation
	-	Forward rotation



NOTE

- When Pr.541 = "1" (with sign)
 - The set frequency cannot be written in EEPROM.
 - When power is turned ON (inverter reset), the initial setting status of the sign bit is "positive" and the set frequency is "0 Hz". (The motor does not operate at the frequency set before turning OFF the power (inverter reset).)
- Setting Pr.811 Set resolution switchover = "1 or 11" changes the unit from 1 r/min to 0.1 r/min. (The Pr.811 is only available for the FR-A800 series.)

8 PPO TYPE NON-SUPPORT SPECIFICATION

8.1 PROFIBUS profiles

The option unit operates as a "slave of the PROFIBUS DP master" or a "controller equivalent to PROFIBUS DP master class 1 on an RS-485 network".

The PROFIBUS profile (data buffer) can be selected from among six different types, "PPO type 1" to "PPO type 5", and "A5NP".

(For the module type "PPO type 1" to "PPO type 5" profiles, refer to [Chapter 7](#).)

Module type is changed with the slave module setting. For details, refer to the instruction manual of the Network Master Configuration Software.

NOTE

- The "A5NP" profile is compatible with the FR-A5NP profile.
Use "A5NP" profile when replacing the FR-A5NP with FR-A8NP, etc.

The configuration of the "A5NP" is as follows.

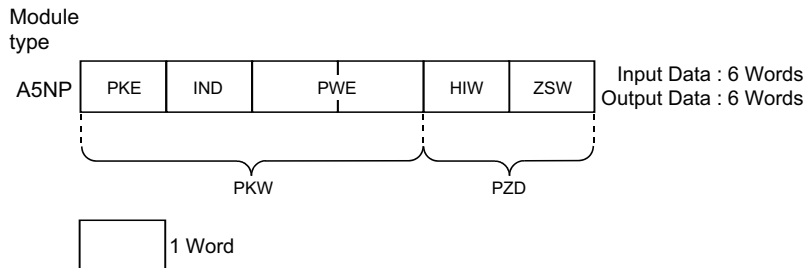

8.2 ID definitions

ID		Definition
PKW (Refer to page 75)	PKE	PNU number (PNU) and task or response Id (AK)
	IND	Index number
	PWE	Set 0 since high bits (Bits 16 to 31) are not used. Lower (Bits 0 to 15): Parameter value
PZD (Refer to page 77)	ZSW	Bits 0 to 7: Inverter status (Command response) *1 Bits 8 to 14: Command count (command request/response) *1
	HIW	Reserved area for extension

- *1 Command request: Message from the master to the slave
Command response: Message from the slave to the master

8.3 Buffer memory configuration

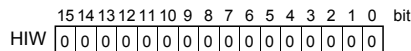
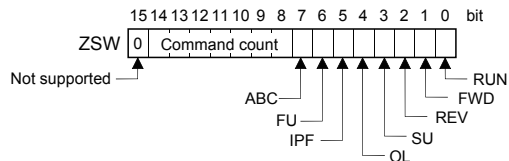
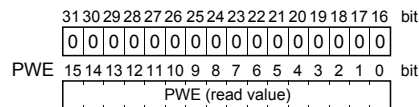
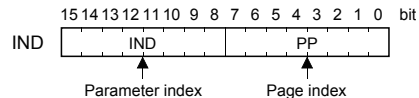
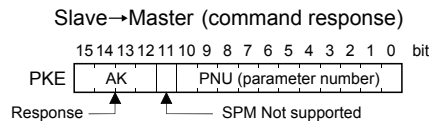
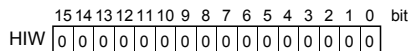
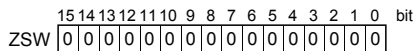
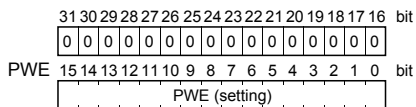
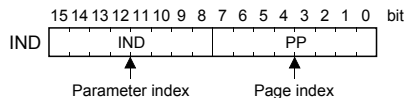
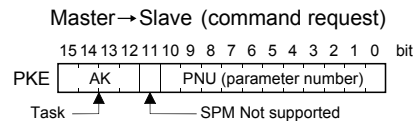

8.4 Buffer memory details

The following indicates the buffer memory details of the PROFIBUS profiles.

◆ PKW

Name		Bit	Definition	
PKE	PNU	0 to 10	PNU number (Together, the PNU and the IND define which data word is being accessed.)	
	SPM	11	Not used (0 is set)	
	AK	12 to 15	[Command request]	
			Value	Operation
			0	No task
			1	Parameter value is requested (read request)
			2	Parameter value (word) is changed (write request)
			Others	Not supported
			[Command response]	
			Value	Operation
0			No response (Busy status)	
1			Inverter can accept data (Ready status)	
7	Command execution error (error number is stored into PWE) (Refer to page 76)			
8	No operation change rights			
Others	Not used			

Name		Bit	Definition																		
IND	PP	0 to 7	Page Index : <ul style="list-style-type: none"> • If IND = 1 (system environment variables (sev) area), the PP values specify different blocks of sev's: <ul style="list-style-type: none"> PP = 0 : sev_I, block I PP = 1 : sev_II, block II (alarm history) PP = 2 : sev_III, block III (For details, refer to page 81.) • If IND is other than 01, set PP to 0. 																		
	IND	8 to 15	Parameter Index : Specifies the area from which Parameter Number (PNU) is being accessed. (For details, refer to page 80 .) IND = 0: real-time monitor area IND = 1: system environment variable(sev) area (3 blocks) IND = 2: normal parameter area IND = 3: Pr.900 to calibration parameter (frequency) area IND = 4: Pr.900 to calibration parameter (%) area																		
PWE		0 to 15	PNU read value/write value When command response AK = "7" (command execution error), PWE definition is as follows. <table border="1" data-bbox="463 542 1220 829"> <thead> <tr> <th>PNU</th> <th>Error definition</th> </tr> </thead> <tbody> <tr> <td>H0</td> <td>Without error</td> </tr> <tr> <td>H1</td> <td>Unsupported task (includes writing)</td> </tr> <tr> <td>H2</td> <td>Invalid parameter index (IND)</td> </tr> <tr> <td>H3</td> <td>Invalid PNU</td> </tr> <tr> <td>H6</td> <td>Invalid page index (PP)</td> </tr> <tr> <td>H41</td> <td>Mode error</td> </tr> <tr> <td>H42</td> <td>Instruction code error</td> </tr> <tr> <td>H43</td> <td>Data setting range error</td> </tr> </tbody> </table>	PNU	Error definition	H0	Without error	H1	Unsupported task (includes writing)	H2	Invalid parameter index (IND)	H3	Invalid PNU	H6	Invalid page index (PP)	H41	Mode error	H42	Instruction code error	H43	Data setting range error
	PNU	Error definition																			
H0	Without error																				
H1	Unsupported task (includes writing)																				
H2	Invalid parameter index (IND)																				
H3	Invalid PNU																				
H6	Invalid page index (PP)																				
H41	Mode error																				
H42	Instruction code error																				
H43	Data setting range error																				
		16 to 31	Not used (0 is set)																		

◆ PZD

Name		Bit	Definition
ZSW	RUN signal	0	0 : OFF 1 : ON (inverter running)
	FWD signal	1	0 : OFF 1 : ON (forward rotation operation being performed)
	REV signal	2	0 : OFF 1 : ON (reverse rotation operation being performed)
	SU signal	3	0 : OFF 1 : ON (up to frequency)
	OL signal	4	0 : OFF 1 : ON (overload alarm)
	IPF signal	5	0 : OFF 1 : ON (an instantaneous power failure or undervoltage occurs)
	FU signal	6	0 : OFF 1 : ON (output frequency being detected)
	ALM signal	7	0 : Inverter normal 1 : Inverter alarm occurrence
	Command count	8 to 14	Command count The command count is an optional feature maintained by the PROFIBUS master and can range from H00 to H7F. The option unit copies the command count from the command it receives to the same byte offset in the response it sends. The master may use this to synchronize commands and responses.
—	15	Not used (0 is returned)	
HIW	0 to 15	Not used (0 is set)	

- For master-to-slave messages (command request), bits 0 to 7 are not used and must be set to 0. The bit-wise data here do not reflect **Pr.190 to Pr. 196** (output terminal function selection).
- At command response, signals are the same. Signals are not affected by settings of **Pr.190 to Pr.196** (output terminal function selection).

 **NOTE**

- Only when the contents of the command request (request for changing the inverter setting: PKW) from the master changed, the inverter processes the request. If the contents of the command request are identical with those of the last request, the inverter does not process the request. (The received request is cleared.)
For instance, while the master keeps sending the "network operation mode enable" command, changing the mode to the PU operation mode with switchover function does not allow the "network operation mode enable" command to be executed due to the same contents as that sent last time. Therefore, the operation mode remains the PU operation mode without changing to the Network operation mode.
In this case, send another command as "PU operation mode enable" from the master once, then send the "network operation mode enable" command again.

8.5 Outline of PNU

You can use the PNU to make inverter settings from the network.

The data used with the network is denoted PNU (P) to differentiate it from the parameter (Pr.) of the inverter.

This chapter explains the module type "A5NP".



- Parameter definitions differ according to the module type selected. When using "PPO type 1" to "PPO type 5", refer to [page 54](#).

8.6 PROFIBUS PNU (module type A5NP)

8.6.1 Real-time monitor area (IND=H0000 (IND=H00, PP=H00))

Different inverter data can be monitored using the master.

IND	PNU	Item	Increments
H0000	H0	Output frequency	0.01 Hz
H0000	H1	Output current	0.01 A/0.1 A
H0000	H2	Output voltage	0.1 V
.	.	.	.
.	.	.	.
.	.	.	.



- The PNU number of each monitor item corresponds to the number of the inverter's RS-485 communication dedicated monitor that is one less than the PNU number in hexadecimal.
For the details of the monitor items, refer to the monitor display section in the Instruction Manual (Detailed) of the inverter.

8.6.2 System environment variable (sev) area (IND = H01PP (IND = H01, PP = H00, H01))

◆ SEV Interface (IND = H01, PP = H00, SEV_I, Block I)

◆ Parameter clear

Inverter reset and parameter clear can be performed from the master.

IND	PNU	Item	Data definition
H0100	H1	Inverter reset	H0000
H0100	H2	Parameter clear	H965A
H0100	H3	All parameter clear	H99AA
H0100	H5	Parameter clear *1	H5A96
H0100	H6	All parameter clear *1	HAA99

*1 The communication parameters are not cleared. For details of the communication parameters, refer to the Instruction Manual (Detailed) of the inverter.

◆ Inverter status/operation command

The inverter status can be monitored and operation command can be given from the master.

IND	PNU	Item																																							
H0100	HA	Inverter status For details, refer to ZSW on page 77 .																																							
		Run command																																							
		<table border="1"> <thead> <tr> <th>Bit</th> <th>Name</th> <th>Definition</th> </tr> </thead> <tbody> <tr> <td>0</td> <td>—</td> <td>Not used (0 is set)</td> </tr> <tr> <td>1</td> <td>Terminal STF</td> <td>Forward rotation command</td> </tr> <tr> <td>2</td> <td>Terminal STR</td> <td>Reverse rotation command</td> </tr> <tr> <td>3</td> <td>Terminal RH</td> <td>High-speed operation command *1</td> </tr> <tr> <td>4</td> <td>Terminal RM</td> <td>Middle-speed operation command *1</td> </tr> <tr> <td>5</td> <td>Terminal RL</td> <td>Low-speed operation command *1</td> </tr> <tr> <td>6</td> <td>Terminal JOG</td> <td>JOG operation selection *1</td> </tr> <tr> <td>7</td> <td>Terminal RT</td> <td>Second function selection *1</td> </tr> <tr> <td>8</td> <td>Terminal AU</td> <td>Terminal 4 input selection *1</td> </tr> <tr> <td>9</td> <td>Terminal CS</td> <td>Restart after instantaneous power failure selection *1, *2</td> </tr> <tr> <td>10</td> <td>Terminal MRS</td> <td>Inverter output shut off *1</td> </tr> <tr> <td>11 to 15</td> <td>—</td> <td>Not used (0 is set)</td> </tr> </tbody> </table>	Bit	Name	Definition	0	—	Not used (0 is set)	1	Terminal STF	Forward rotation command	2	Terminal STR	Reverse rotation command	3	Terminal RH	High-speed operation command *1	4	Terminal RM	Middle-speed operation command *1	5	Terminal RL	Low-speed operation command *1	6	Terminal JOG	JOG operation selection *1	7	Terminal RT	Second function selection *1	8	Terminal AU	Terminal 4 input selection *1	9	Terminal CS	Restart after instantaneous power failure selection *1, *2	10	Terminal MRS	Inverter output shut off *1	11 to 15	—	Not used (0 is set)
		Bit	Name	Definition																																					
		0	—	Not used (0 is set)																																					
		1	Terminal STF	Forward rotation command																																					
		2	Terminal STR	Reverse rotation command																																					
		3	Terminal RH	High-speed operation command *1																																					
		4	Terminal RM	Middle-speed operation command *1																																					
		5	Terminal RL	Low-speed operation command *1																																					
		6	Terminal JOG	JOG operation selection *1																																					
		7	Terminal RT	Second function selection *1																																					
		8	Terminal AU	Terminal 4 input selection *1																																					
9	Terminal CS	Restart after instantaneous power failure selection *1, *2																																							
10	Terminal MRS	Inverter output shut off *1																																							
11 to 15	—	Not used (0 is set)																																							
		Functions assigned to the terminals RH, RM, RL, JOG, RT, AU, CS and MRS are activated.																																							

*1 Signal names are initial values. Using **Pr.180 to Pr.187**, you can change output signal functions. Refer to the Instruction Manual (Detailed) of the inverter for details of **Pr.180 to Pr.187**.

*2 For the FR-F800 series, no function is assigned in the initial setting.

◆ **Operation mode read/write**

Read/write of the operation mode can be performed from the master.

IND	PNU	Item	Data definition
H0100	HB	Operation mode	External operation mode : H10 PU operation mode : H11 (When Pr.79 = "6") Network operation mode : H14

◆ **Set frequency read/write**

The frequency set to the inverter can be read/written from the master.

IND	PNU	Item	Data definition
H0100	HD	Set frequency (RAM) *1	Set frequency (RAM) is read or written.
H0100	HE	Set frequency (EEPROM) *1, *2	Write set frequency to EEPROM.

*1 Writing to PNU = HD or PNU = HE can be read out from PNU = HD.

*2 To change the running frequency consecutively, always write data to the inverter RAM.

◆ **Terminal input read**

The analog input values of terminals 2, 4, and 1 can be read.

IND	PNU	Item	Minimum setting increments
H0100	HF	Terminal 2 input value read	0.1%
H0100	H10	Terminal 4 input value read	0.1%
H0100	H11	Terminal 1 input value read	0.1%

◆ Faults History (IND = H01, PP = H01, SEV_II, Block II)

The past eight inverter fault records can be read.

(For the data codes or details of fault records, refer to the Instruction Manual (Detailed) of the inverter.)

IND	PNU	Item
H0101	H0	Latest fault/Batch clearing of fault records *1
H0101	H1	Second fault in past is read
H0101	H2	Third fault in past is read
H0101	H3	Forth fault in past is read
H0101	H4	Fifth fault in past is read
H0101	H5	Sixth fault in past is read
H0101	H6	Seventh fault in past is read
H0101	H7	Eighth fault in past is read

*1 Writing a value of H0000 to this parameter clear all fault history. All other parameters at this index are read only.

8.7 Standard parameters

8.7.1 Normal parameter area (IND = H0200 (IND = H02, PP = H00))

You can use the PNU to make parameter settings from the network.

The table below lists PNU numbers corresponding to parameter numbers.

Standard parameter examples are introduced below. Refer to the examples and make parameter settings.

Refer to the Instruction Manual (Detailed) of the inverter for details of the parameters.

- Example of parameter list

IND	PNU	Pr.	Name
H0200	H0	0	Torque boost
	H1	1	Maximum frequency
	H2	2	Minimum frequency
	H3	3	Base frequency
	H4	4	Multi-speed setting (high speed)
	H5	5	Multi-speed setting (middle speed)
	H6	6	Multi-speed setting (low speed)
⋮	⋮	⋮	



- Write to **Pr.77** and **Pr.79** is not allowed from the network with FR-A8NP. (Read is allowed.)

8.7.2 Pr.900 to calibration parameter (frequency) area (IND=H0300 (IND=H03, PP=H00))

The following parameters can be set with IND=H0300.

Refer to the Instruction Manual (Detailed) of the inverter for details of the parameters.

IND	PNU	Pr.	Name
H0300	H0	C0(900)	FM/CA terminal calibration
H0300	H1	C1(901)	AM terminal calibration
H0300	H2	C2(902)	Terminal 2 frequency setting bias frequency
H0300	H3	125(903)	Terminal 2 frequency setting gain frequency
H0300	H4	C5(904)	Terminal 4 frequency setting bias frequency
H0300	H5	126(905)	Terminal 4 frequency setting gain frequency
H0300	H11	C12(917)	Terminal 1 bias frequency (speed)
H0300	H12	C14(918)	Terminal 1 gain frequency (speed)
H0300	H13	C16(919)	Terminal 1 bias command (torque)
H0300	H14	C18(920)	Terminal 1 gain command (torque)
H0300	H1E	C8(930)	Current output bias signal
H0300	H1F	C10(931)	Current output gain signal
H0300	H20	C38(932)	Terminal 4 bias command (torque)
H0300	H21	C40(933)	Terminal 4 gain command (torque)
H0300	H22	C42(934)	PID display bias coefficient
H0300	H23	C44(935)	PID display gain coefficient

8.7.3 Pr.900 to calibration parameter (%) area (IND=H0400 (IND=H04, PP=H00))

The following parameters can be set with IND=H0400.

Refer to the Instruction Manual (Detailed) of the inverter for details of the parameters.

IND	PNU	Pr.	Name
H0400	H2	C3(902)	Terminal 2 frequency setting bias
H0400	H3	C4(903)	Terminal 2 frequency setting gain
H0400	H4	C6(904)	Terminal 4 frequency setting bias
H0400	H5	C7(905)	Terminal 4 frequency setting gain
H0400	H11	C13(917)	Terminal 1 bias (speed)
H0400	H12	C15(918)	Terminal 1 gain (speed)
H0400	H13	C16(919)	Terminal 1 bias (torque)
H0400	H14	C19(920)	Terminal 1 gain (torque)
H0400	H1E	C9(930)	Current output bias current
H0400	H1F	C11(931)	Current output gain current
H0400	H20	C39(932)	Terminal 4 bias (torque)
H0400	H21	C41(933)	Terminal 4 gain (torque)
H0400	H22	C43(934)	PID display bias analog value
H0400	H23	C45(935)	PID display gain analog value

9 TROUBLESHOOTING

When a fault occurs where the inverter trips itself and the option unit, check the inverter's operation panel, the LED on the option unit, and the following checkpoints to identify the cause, then take appropriate countermeasures. If the fault does not correspond to any of the following faults or if you have any other problem, please contact your sales representative.

Operation panel display on the inverter	LED on FR-A8NP	Possible cause		Checkpoint / troubleshooting
0.00	OFF	The option unit is not operating.	The option unit is not mounted properly.	Check if the option unit is mounted properly.
			PROFIBUS communication is not established with the master. (Incorrect node address setting)	Set the same node address with the master on the inverter (FR-A8NP) using the node address switches. (Turn OFF, then ON the power supply after changing the node address setting on the inverter (FR-A8NP).)
			PROFIBUS communication is not established with the master. (Incorrect GSD file has been registered.)	Register the correct GSD file with a configuration software, and set the network configuration to the master.
			PROFIBUS communication is not established with the master. (Incorrect wiring)	Check the wiring of the option unit. D+ PROFIBUS transmitting/receiving data+ (B line) D- PROFIBUS transmitting/receiving data- (A line)
			—	Reset the inverter. Perform all parameter clear to initialize all parameter settings, then turn ON the inverter power again.
		The network is unstable.	The network cables are not connected correctly.	Check if the network cables are connected properly between the nodes.
			The PROFIBUS communication is not established with the master. (Unstable bus line)	Connect a terminating resistor. If a terminating resistor has been already connected, check if it is connected properly.

Operation panel display on the inverter	LED on FR-A8NP	Possible cause		Checkpoint / troubleshooting
0.00	OFF	The network is unstable.	The network setting is incorrect.	Check the network setting with the PROFIBUS-DP network configuration software.
			The inverter is affected by the other nodes.	Check if any network error has occurred in the other nodes.
		No master is present in the network, or the master is not properly operating.	Check the connection and the operation of the PROFIBUS-DP master.	
	Red (ON)	The PROFIBUS communication had been established (the green LED had been ON), but the master stopped transmitting data to the option unit during an inverter stop.		Check the master ladder, etc., and remove the causes that disconnect the data transmission between the master and the option unit.
E.OP1	Red (ON)	A communication cable break occurred after the PROFIBUS communication had been established (green LED had been ON).		Check the connection and the wiring of the communication cable.
		Communication errors occurred consecutively after the PROFIBUS communication had been established (green LED had been ON).		Connect a terminating resistor. If a terminating resistor has been already connected, check if it is connected properly.
		The PROFIBUS communication had been established (the green LED had been ON), but the master stopped transmitting data to the option unit during an inverter operation.		Check the master ladder, etc., and remove the causes that disconnect the data transmission between the master and the option unit.

REVISIONS

*The manual number is given on the bottom left of the back cover.

Print Date	*Manual Number	Revision
Feb. 2014	IB(NA)-0600528ENG-A	First edition
Oct. 2014	IB(NA)-0600528ENG-B	Addition • Compatibility with the FR-F800 series

INVERTER

