



INVERTER

Plug-in option

FR-A8NCE

INSTRUCTION MANUAL

CC-Link IE Field Network
communication function

PRE-OPERATION INSTRUCTIONS	1
INSTALLATION	2
WIRING	3
INVERTER SETTING	4
FUNCTION OVERVIEW	5
I/O SIGNAL LIST	6
DETAILS OF I/O SIGNALS	7
PROGRAMMING EXAMPLES	8

Thank you for choosing this Mitsubishi inverter plug-in option.

This Instruction Manual provides handling information and precautions for use of this product. Incorrect handling might cause an unexpected fault. Before using this product, always read this Instruction Manual carefully to use this product correctly.

Please forward this Instruction Manual to the end user.

Safety instructions

Do not attempt to install, operate, maintain or inspect the product until you have read through this Instruction Manual and appended documents carefully and can use the equipment correctly. Do not use this product until you have a full knowledge of the equipment, safety information and instructions. In this Instruction Manual, the safety instruction levels are classified into "Warning" and "Caution".



Warning

Incorrect handling may cause hazardous conditions, resulting in death or severe injury.



Caution

Incorrect handling may cause hazardous conditions, resulting in medium or slight injury, or may cause only material damage.

The  **Caution** level may even lead to a serious consequence according to conditions. Both instruction levels must be followed because these are important to personal safety.

◆ Electric Shock Prevention



Warning

- While the inverter power is ON, do not open the front cover or the wiring cover. Do not run the inverter with the front cover or the wiring cover removed. Otherwise you may access the exposed high voltage terminals or the charging part of the circuitry and get an electric shock.
- Do not remove the inverter front cover even if the power supply is disconnected. The only exception for this would be when performing wiring and periodic inspection. You may accidentally touch the charged inverter circuits and get an electric shock.
- Before wiring or inspection, LED indication of the inverter unit operation panel must be switched OFF. Any person who is involved in wiring or inspection shall wait for at least 10 minutes after the power supply has been switched OFF and check that there is no residual voltage using a tester or the like. For some time after the power-OFF, a high voltage remains in the smoothing capacitor, and it is dangerous.
- Any person who is involved in wiring or inspection of this equipment shall be fully competent to do the work.
- The plug-in option must be installed before wiring. Otherwise you may get an electric shock or be injured.
- Do not touch the plug-in option or handle the cables with wet hands. Otherwise you may get an electric shock.
- Do not subject the cables to scratches, excessive stress, heavy loads or pinching. Otherwise you may get an electric shock.

◆ Injury Prevention



Caution

- The voltage applied to each terminal must be the ones specified in the Instruction Manual. Otherwise a burst, damage, etc. may occur.
- The cables must be connected to the correct terminals. Otherwise a burst, damage, etc. may occur.
- The polarity (+ and -) must be correct. Otherwise a burst or damage may occur.
- While power is ON or for some time after power OFF, do not touch the inverter as it will be extremely hot. Touching these devices may cause a burn.

◆ Additional Instructions

The following instructions must be also followed. If the product is handled incorrectly, it may cause unexpected fault, an injury, or an electric shock.

Caution

Transportation and mounting

- Do not install or operate the plug-in option if it is damaged or has parts missing.
- Do not stand or rest heavy objects on the product.
- The mounting orientation must be correct.
- Foreign conductive objects must be prevented from entering the inverter. That includes screws and metal fragments or other flammable substance such as oil.
- If halogen-based materials (fluorine, chlorine, bromine, iodine, etc.) infiltrate into a Mitsubishi product, the product will be damaged. Halogen-based materials are often included in fumigant, which is used to sterilize or disinfest wooden packages. When packaging, prevent residual fumigant components from being infiltrated into Mitsubishi products, or use an alternative sterilization or disinfection method (heat disinfection, etc.) for packaging. Sterilization or disinfection of wooden package should also be performed before packaging the product.

Trial run

- Before starting operation, each parameter must be confirmed and adjusted. A failure to do so may cause some machines to make unexpected motions.

Warning

Usage

- Do not modify the equipment.
- Do not perform parts removal which is not instructed in this manual. Doing so may lead to fault or damage of the product.

Caution

Usage

- When parameter clear or all parameter clear is performed, the required parameters must be set again before starting operations. Because all parameters return to their initial values.
- Static electricity in your body must be discharged before you touch the product.

Maintenance, inspection and parts replacement

- Do not carry out a megger (insulation resistance) test.

Disposal

- The product must be treated as industrial waste.

General instruction

- Many of the diagrams and drawings in this Instruction Manual show the inverter without a cover or partially open for explanation. Never operate the inverter in this manner. The cover must be reinstalled and the instructions in the Instruction Manual must be followed when operating the inverter.

— CONTENTS —

1	PRE-OPERATION INSTRUCTIONS	6
1.1	Unpacking and product confirmation.....	6
1.2	Parts.....	7
1.3	CC-Link IE Field Network communication specifications	9
2	INSTALLATION	10
2.1	Pre-installation instructions	10
2.2	Installation procedure	11
3	WIRING	15
3.1	System configuration example.....	15
3.2	Network configuration.....	16
3.3	Network components	17
3.3.1	Connection cable	17
3.3.2	Hubs.....	17
3.4	Wiring.....	18
3.4.1	Ethernet cable connection	18
3.4.2	Precautions	20
4	INVERTER SETTING	23
4.1	Parameter list.....	23
4.2	Operation mode setting	25
4.2.1	Operation mode switching and communication startup mode (Pr.79, Pr.340).....	25
4.3	Operation at communication error occurrence	28
4.3.1	Operation selection at communication error occurrence (Pr.500 to Pr.502, Pr.779)	28
4.3.2	Fault and measures	32
4.4	Inverter reset.....	33
4.5	CC-Link IE Field Network function setting	35

4.5.1	Network number setting (Pr. 434)	35
4.5.2	Station number setting (Pr. 435)	35
4.5.3	Frequency command with sign (Pr. 541)	36

5 FUNCTION OVERVIEW 38

5.1	Output from the inverter through the network	38
5.2	Input to the inverter through the network	39
5.3	Cyclic transmission	40
5.3.1	Data flow and link device assignment.....	40

6 I/O SIGNAL LIST 43

6.1	Remote I/O (64 points fixed)	43
6.2	Remote register (128 words fixed)	46

7 DETAILS OF I/O SIGNALS 52

7.1	Details of remote input and output signals	52
7.1.1	Output signals (master module to inverter (FR-A8NCE)).....	52
7.1.2	Input signals (inverter (FR-A8NCE) to master module)	55
7.2	Details of remote register	57
7.2.1	Remote register (master module to inverter (FR-A8NCE)).....	57
7.2.2	Remote register (inverter (FR-A8NCE) to master module).....	59
7.2.3	Instruction codes	62
7.2.4	Monitor codes	66
7.3	Torque command / torque limit through CC-Link IE Field Network communication (only for the FR-A800 series)	67

8 PROGRAMMING EXAMPLES 69

8.1	Programming example for reading the inverter status	74
8.2	Programming example for setting the operation mode	75
8.3	Programming example for setting the operation commands	76
8.4	Programming example for monitoring the output frequency	77

8.5	Programming example for parameter reading.....	78
8.6	Programming example for parameter writing	79
8.7	Programming example for setting the running frequency	80
8.8	Programming example for fault record reading	82
8.9	Programming example for resetting the inverter at inverter error.....	83
8.10	Instructions	84



1 PRE-OPERATION INSTRUCTIONS

1.1 Unpacking and product confirmation

Take the plug-in option out of the package, check the product name, and confirm that the product is as you ordered and intact. This product is a plug-in option for the FR-A800/F800 series.

◆ Product confirmation

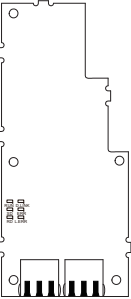
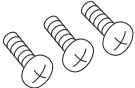
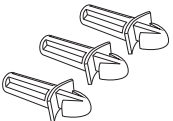
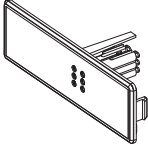
Check the enclosed items.

<p>Plug-in option 1</p>  <p>The diagram shows a rectangular printed circuit board (PCB) with a complex shape. It has several circular holes and a notch on the right side. At the bottom, there are two RJ45 ports. The text 'digital drivers' is printed on the board.</p>	<p>Mounting screw (M3 × 8 mm) 3 (Refer to page 12.)</p>  <p>The diagram shows three screws with Phillips heads and hexagonal bases.</p>	<p>Spacer 3 (Refer to page 12.)</p>  <p>The diagram shows three cylindrical spacers with a flange on one end and a hole on the other.</p>	<p>Communication option LED display cover 1 (Refer to page 11.)</p>  <p>The diagram shows a rectangular cover with a series of pins or connectors along one edge.</p>	<p>Earth plate 1 (Refer to page 12.)</p>  <p>The diagram shows a long, thin metal plate with a hole at one end and a bent section at the other.</p>
--	--	--	---	--

NOTE

- ETHERNET is a registered trademark of Xerox Corporation of the United States.

1.2 Parts

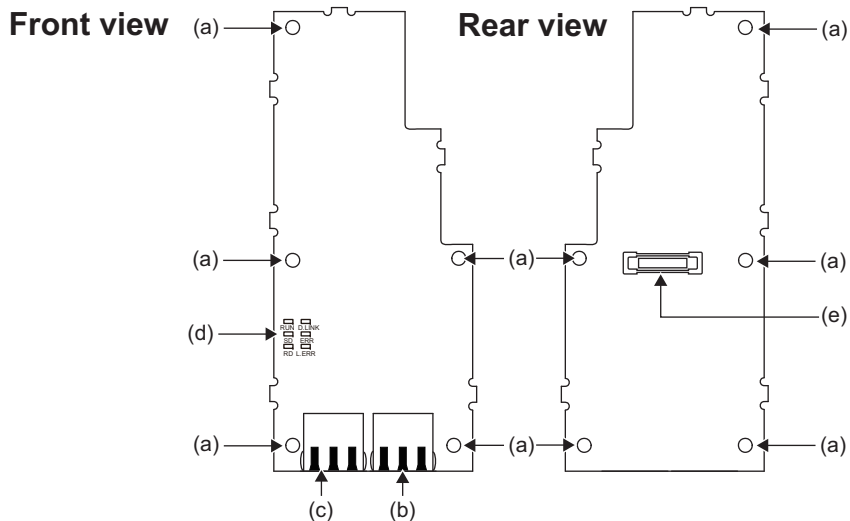

Symbol	Name	Description	Refer to page
a	Mounting hole	Fixes the option to the inverter with screws, or installs spacers.	12
b	Connector for communication (PORT1)	For an Ethernet cable which connects to the network.	18
c	Connector for communication (PORT2)	For an Ethernet cable which connects to the network.	18
d	Operation status indication LED	Lit/flicker of the LED indicate operation status.	8
e	Connector	Connects to the option connector of the inverter.	12

◆ Operation status LEDs

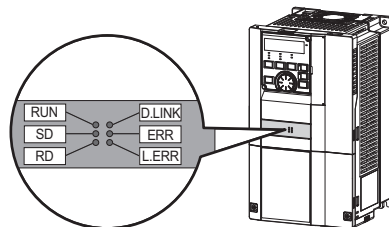

LED name	Description	ON	OFF
RUN	Operation status	Normal operation (normal 5 V internal voltage) *1	Hardware failure
SD	Transmission status	Data transmitting	No data transmitting
RD	Reception status	Data receiving	No data receiving
D.LINK	Cyclic communication status	Cyclic transmitting	No cyclic transmitting or disconnected
ERR	Node failure status *2	Node failure	Normal operation
L.ERR	Link error	Received data error	Received data normal

*1 Also lit in no-communication state.

*2 This LED indicates a communication break between the master station and FR-A8NCE (due to cable disconnection or breakage, power-OFF of the master power supply, or reset, etc.)

1.3 CC-Link IE Field Network communication specifications

Item	Description			
Type	Inverter plug-in option type, RJ-45 connector connection method			
Power supply	Supplied from the inverter			
Transmission speed	1 Gbps			
Communication method	Token passing			
Number of units connected	120 units at max. (64 units when all stations are inverters handling 128-word transmissions.) Different devices can be connected together.			
Maximum distance between nodes	100 m			
Maximum number of branches	No upper limit within the same Ethernet system			
Topology	Line, star, ring, or a combination of line and star			
Connection cable	Ethernet cable (IEEE 802.3 1000BASE-T compliant cable or ANSI/TIA/EIA-568-B (Category 5e) compliant shielded 4-pair branched cable)			
Connector	Shielded RJ-45			
Node type	Intelligent device station	Maximum cyclic size (of one node)	RX	64 bits
			RY	64 bits
			RWr	128 words
			RWw	128 words
		Transient transmission	Not available	

2 INSTALLATION

2.1 Pre-installation instructions

Check that the inverter's input power and the control circuit power are both OFF.

Caution

- With input power ON, do not install or remove the plug-in option. Otherwise, the inverter and plug-in option may be damaged.
- To avoid damage due to static electricity, static electricity in your body must be discharged before you touch the product.

2.2 Installation procedure

◆ Installing the communication option LED display cover

- (1) Remove the inverter front cover. (Refer to Chapter 2 of the Instruction Manual (Detailed) of the inverter for details on how to remove the front cover.)

Mount the cover for displaying the operation status indication LED for the communication option on the inverter front cover.

- (2) Cut off hooks on the rear of the inverter front cover with nipper, etc. and open the window for fitting the LED display cover.

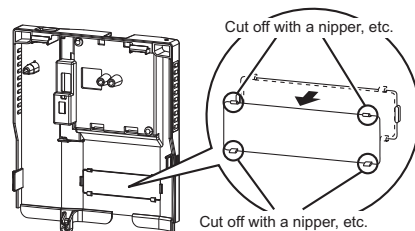

- (3) Fit the communication option LED display cover to the front side of the front cover. Align the LED display cover with the LED position on the circuit board of the option. Push the LED display cover until it is fixed with the hooks.

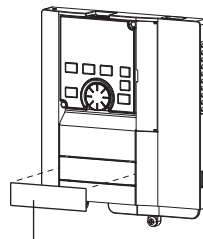

Communication option LED display cover



The protective structure (JEM1030) changes to the open type (IP00).

⚠ Caution

- Take care not to hurt your hand and such with portions left by cutting hooks of the rear of the front cover.

◆ Installing the option

- (1) For the three mounting holes (as shown in the next page) that will not be tightened with mounting screws, insert spacers.
- (2) Fit the connector of the plug-in option to the guide of the connector on the inverter unit side, and insert the plug-in option as far as it goes. (Insert it to the inverter option connector 1.)
- (3) Fit the one location on the left of the earth plate (as shown in the next page) securely to the inverter unit by screwing in the supplied mounting screw. (tightening torque 0.33 N·m to 0.40 N·m)
- (4) Fit the one location on the left of the plug-in option securely to the inverter unit and the right of the plug-in option to the inverter unit together with the earth plate by screwing in the supplied mounting screws. (tightening torque 0.33 N·m to 0.40 N·m) If the screw holes do not line up, the connector may not be inserted deep enough. Check the connector.

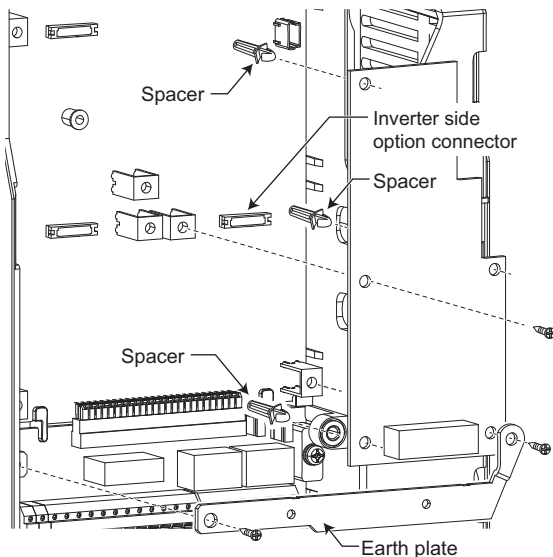

Example of installation to connector 1

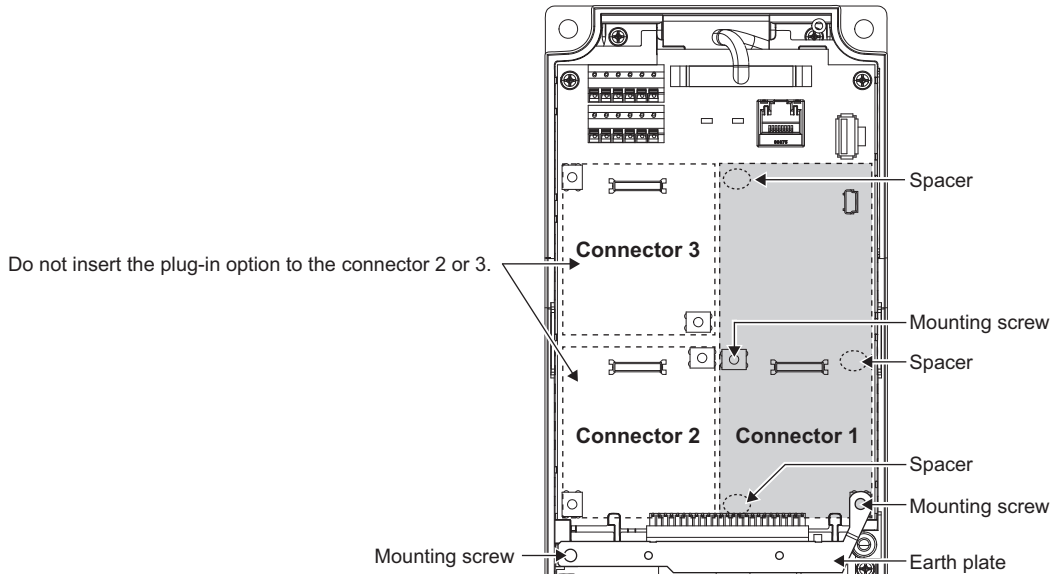

Insertion positions for screws and spacers

 **NOTE**

- When mounting/removing the plug-in option, hold the sides of the option. Do not press on the parts on the option circuit board. Stress applied to the parts by pressing, etc. may cause a failure.
- Caution must be applied to mounting screws falling off when removing and mounting the plug-in option.
- When using this plug-in option, insert it to the inverter option connector 1. If it is inserted to the option connector 2 or 3, the protective function (E.2 or E.3) is activated and the inverter will not operate.
Even if the option is inserted to the option connector 1, when the inverter cannot recognize that the option is mounted due to improper installation, etc., the protective function (E.1) is activated.

Mounted position	Fault indication
Option connector 1	E. 1
Option connector 2	E. 2
Option connector 3	E. 3

- When removing the plug-in option, remove the two screws on the left and right, then pull it straight out. Pressure applied to the connector and to the option board may break the option.
- Always attach the earth plate because a malfunction due to noises may occur without it.

3.1 System configuration example

(1) Programmable controller side

Mount the "RJ71EN71", "RJ71GF11-T2", "QJ71GF11-T2", or "LJ71GF11-T2" type CC-Link IE Field Network master/local module on the main or extension base unit having the programmable controller CPU used as the master station.

(2) Inverter side

Mount the option (FR-A8NCE) on the inverter.

(3) Connect the CC-Link IE Field Network programmable controller (master station) to FR-A8NCE with an Ethernet cable.

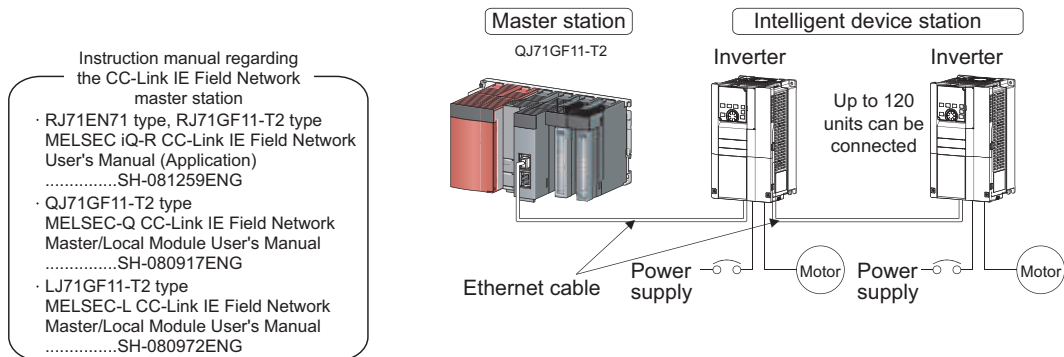

3.2 Network configuration

◆ Network topology

The network can be wired into star topology, line topology, and ring topology.

A network can consist of a combination of star and line topologies, but the ring topology cannot be combined with star or line topology.

Item	Description
Star topology	Modules are configured into a star using a switching hub and Ethernet cables. Slave stations can be easily added in a star topology. Furthermore, data link continues among normally-operating stations in a star topology. *1
Line topology	Modules are configured into a line with Ethernet cables and without a switching hub. If an error occurs, the station in error and the stations after that will be disconnected from the network. *1
Ring topology	Modules are configured into a ring using Ethernet cables. Data link continues among normallyoperating stations without a switching hub. *1

*1 Add/remove slave stations one by one. If multiple slave stations are added/removed at a time, all stations on the network will be reconnected, resulting in a momentarily error in all the stations.

◆ Station number and connection position

Modules can be connected in any order regardless of the station number.

◆ Cascade connection

Up to 20-layer connection is available for the cascade connection.

◆ Replacing CC-Link IE Field Network devices

For star topology, slave stations can be replaced without powering off the whole system.



- Refer to the MELSEC iQ-R, MELSEC-Q, or MELSEC-L CC-Link IE Field Network Master/Local Module User's Manual for the detailed network configurations.

3.3 Network components

This section describes components comprising the CC-Link IE Field Network.

3.3.1 Connection cable

For wiring, use the 1000BASE-T compliant Ethernet cables.

Ethernet cable	Connector	Type
Category 5e or higher (Double shielded/STP) Straight cable	RJ-45 connector	The following conditioning cables: <ul style="list-style-type: none">• IEEE802.3 (1000BASE-T)• ANSI/TIA/EIA-568-B (Category 5e)



NOTE

- For CC-Link IE Field Network wiring, use the recommended wiring components by CC-Link Partner Association.
- Cables for CC-Link IE Controller Network cannot be used for CC-Link IE Field Network.
- Some cable connector shapes are not compatible with FR-A8NCE.

3.3.2 Hubs

Use hubs that meet the conditions listed below:

- Compliance with the IEEE802.3 (1000BASE-T)
- Support of the auto MDI/MDI-X function
- Support of the auto-negotiation function
- Switching hub (layer 2 switch) *1

*1 A repeater hub is not available.

Operation is not guaranteed if the hubs do not meet these conditions.

Industrial switching hub

Type	Manufacturer
NZ2EHG-T8	Mitsubishi Electric Corporation

3.4 Wiring

This section describes the cable wiring and precautions. For network configuration, cables, and hubs used for the wiring, refer to [page 16](#) and subsequent pages.

3.4.1 Ethernet cable connection

◆ Connecting the cable

- (1) Turn OFF the inverter power supply.
- (2) Remove the front cover.
- (3) Check the direction of the Ethernet cable connector.
Insert the connector to the communication connector of FR-A8NCE until it clicks.

◆ Disconnecting the cable

- (1) Turn OFF the inverter power supply.
- (2) Remove the front cover.
- (3) Hold down the latch on the Ethernet cable connector, and pull out the cable while holding the latch.

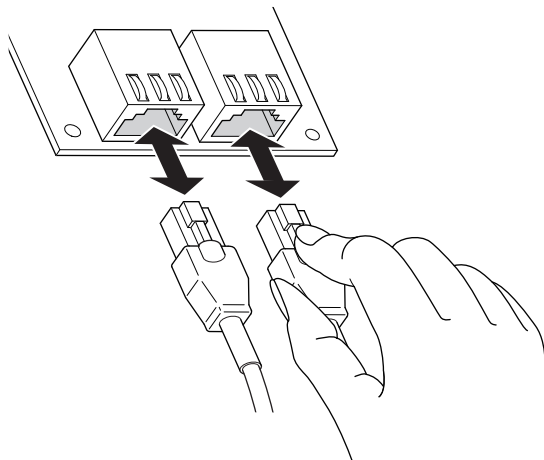

NOTE

- PORT1 and PORT2 do not need to be distinguished.
 - When only one connector is used in star topology, either PORT1 or PORT2 is applicable.
 - When using two connectors for line topology and ring topology, an Ethernet cable can be connected to the connectors in any combination. For example, the cable can be connected between PORT1s or between PORT1 and PORT2.

Connection between PORT1 and PORT1, PORT2 and PORT2

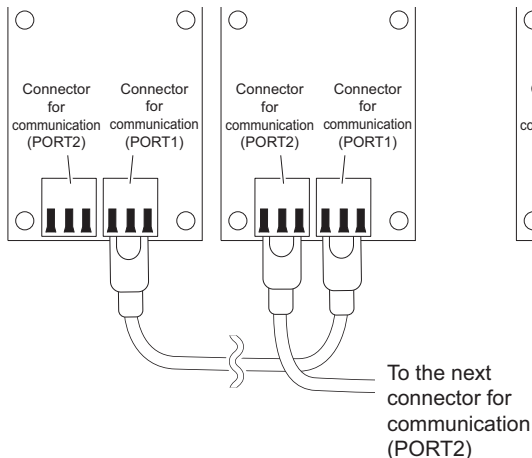

Connection between PORT1 and PORT2

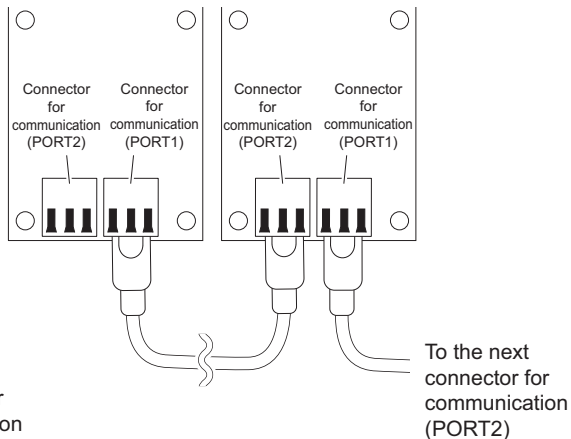

3.4.2 Precautions

This section describes wiring precautions.

◆ Handling of the Ethernet cable

- Do not touch the core of the cable-side or module-side connector, and protect it from dirt or dust. If oil from your hand, dirt or dust is attached to the core, it can increase transmission loss, arising a problem in data link.
- Check the following:
 - Is any Ethernet cable disconnected?
 - Is any of the Ethernet cables shorted?
 - Are the connectors securely connected?

◆ Broken Ethernet cable latch

Do not use Ethernet cables with broken latches. Doing so may cause the cable to unplug or malfunction.

◆ Connecting and disconnecting the Ethernet cable

Hold the connector part when connecting and disconnecting the Ethernet cable. Pulling a cable connected to the module may damage the module or cable, or result in malfunction due to poor contact.

◆ Maximum station-to-station distance (maximum cable length)

The maximum station-to-station distance is 100 m. However, the distance may be shorter depending on the operating environment of the cable. For details, contact your cable manufacturer.

◆ Network configuration

Check the instructions on [page 16](#) before wiring, and perform correct wiring.

◆ Connecting/disconnecting a cable and powering ON/OFF a device

When the operations listed below are performed, all stations on the network may be reconnected. At that time, a data link error may momentarily occur in all the stations, and the communication error E.OP1 may occur in the connected inverters.

Network configuration	Operation
Star topology	<ul style="list-style-type: none"> • Powering ON/OFF a slave station or the switching hub • Connecting/disconnecting an Ethernet cable connected to the switching hub • Disconnecting an Ethernet cable from a slave station and connecting it to another slave station or to the switching hub • Disconnecting ten stations or more, or disconnecting half the number of slave stations in the system or more • Changing the network topology when adding a slave station
Line topology, ring topology	<ul style="list-style-type: none"> • Simultaneously powering ON/OFF multiple stations • Simultaneously connecting/disconnecting Ethernet cables to/from multiple stations (When a data link faulty station returns, a data link error will occur in all the stations.) • Disconnecting ten stations or more, or disconnecting half the number of slave stations in the system or more • Changing the network topology when adding a slave station

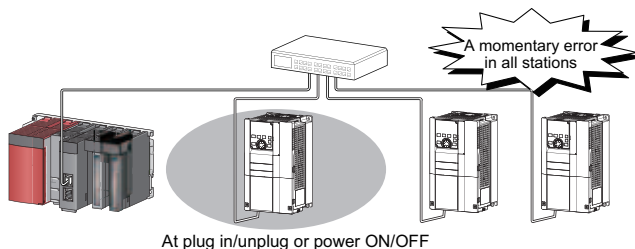

To keep outputting a data link error (inverter communication error), set **Pr.500 Communication error execution waiting time** or **Pr.502 Stop mode selection at communication error**

 **NOTE**

- When wiring cables to the inverter's RS-485 terminals with a plug-in option mounted, take caution not to let the cables touch the circuit board of the option or of the inverter. Otherwise, electromagnetic noises may cause malfunctions.

 **Caution**

- **After wiring, wire offcuts must not be left in the inverter. Wire offcuts can cause an alarm, failure or malfunction.**

4 INVERTER SETTING

4.1 Parameter list

The following parameters are used for the plug-in option (FR-A8NCE). Set the values according to need.

Pr.	Pr. group	Name	Setting range	Minimum setting increments	Initial value	Refer to page
79	D000	Operation mode selection	0 to 4, 6, 7	1	0	25
313 *1	M410*1	DO0 output selection	The setting range depends on the inverter.	1	9999	55
314 *1	M411*1	DO1 output selection				
315 *1	M412*1	DO2 output selection				
338	D010	Communication operation command source	0, 1	1	0	*3
339	D011	Communication speed command source	0, 1, 2	1	0	*3
340	D001	Communication startup mode selection	0, 1, 2, 10, 12	1	0	25
342	N001	Communication EEPROM write selection	0, 1	1	0	*3
349 *1	N010*1	Communication reset selection	0, 1	1	0	35
434 *1, *2	N110*1, *2	Network number (CC-Link IE)	0 to 255	1	0	35
435 *1, *2	N111*1, *2	Station number (CC-Link IE)	0 to 255	1	0	35
500 *1	N011*1	Communication error execution waiting time	0 to 999.8 s	0.1 s	0 s	28

Pr.	Pr. group	Name	Setting range	Minimum setting increments	Initial value	Refer to page
501 *1	N012*1	Communication error occurrence count display	0	1	0	29
502	N013	Stop mode selection at communication error	0 to 3	1	0	29
541 *1	N100*1	Frequency command sign selection	0, 1	1	0	36
550 *2	D012*2	NET mode operation command source selection	0, 1, 9999	1	9999	*3
779	N014	Operation frequency during communication error	0 to 590 Hz, 9999	0.01 Hz	9999	29
804 *4	D400 *4	Torque command source selection	0, 1, 3 to 6	1	0	67
810 *4	H700 *4	Torque limit input method selection	0 to 2 *5	1	0	67

*1 Parameters which can be displayed when the plug-in option (FR-A8NCE) is mounted.

*2 The setting is reflected after inverter reset or at the next power-ON.

*3 Refer to the Instruction Manual (Detailed) of the inverter for the parameter details.

*4 The setting is available only for the FR-A800 series.

*5 This setting of **Pr.810**="2" can be set only when the inverter supports this function. (Refer to [page 67.](#))

4.2 Operation mode setting

4.2.1 Operation mode switching and communication startup mode (Pr.79, Pr.340)

◆ Operation mode switching conditions

Operation mode switching conditions

- The inverter is at a stop;
- Both the STF and STR signals are off; and
- The **Pr.79 Operation mode selection** setting is correct.
(Set with the operation panel of the inverter.)

◆ Operation mode selection at power ON and at restoration from instantaneous power failure

The operation mode at power ON and at restoration from instantaneous power failure can be selected.

Set a value other than "0" in **Pr.340 Communication startup mode selection** to select the network operation mode.

After started in network operation mode, parameter write from the network is enabled.

(Refer to [page 79](#) for a program example for parameter write.)



- Change of the **Pr.340** setting is valid when powering on or resetting the inverter.
- **Pr.340** can be changed with the operation panel independently of the operation mode.
- When setting a value other than 0 in **Pr.340**, make sure that the initial settings of the inverter are correct.
- Refer to the Instruction Manual (Detailed) of the inverter for details of **Pr.79, Pr.340**.

Pr.340 setting	Pr.79 setting	Operation mode at power ON or power restoration	Operation mode switchover
0 (initial value)	0 (initial value)	External operation mode	Switching among the External, PU, and NET operation mode is enabled *1, *4
	1	PU operation mode	PU operation mode fixed
	2	External operation mode	Switching between the External and Net operation mode is enabled *4 Switching to the PU operation mode is disallowed
	3, 4	External/PU combined operation mode	Operation mode switching is disallowed
	6	External operation mode	Switching among the External, PU, and NET operation mode is enabled while running. *4
	7	X12 (MRS) signal ON: external operation mode	Switching among the External, PU, and NET operation mode is enabled *1, *4
		X12 (MRS) signal OFF: external operation mode	External operation mode fixed (Forcibly switched to External operation mode.)
1, 2 *2	0	NET operation mode	Same as when Pr.340 = "0"
	1	PU operation mode	
	2	NET operation mode	
	3, 4	External/PU combined operation mode	
	6	NET operation mode	
	7	X12 (MRS) signal ON..... NET operation mode	
		X12 (MRS) signal OFF.....external operation mode	

Pr.340 setting	Pr.79 setting	Operation mode at power ON or power restoration	Operation mode switchover
10, 12 *2	0	NET operation mode	Switching between the PU and NET operation mode is enabled *3, *4
	1	PU operation mode	Same as when Pr.340 = "0"
	2	NET operation mode	NET operation mode fixed
	3, 4	External/PU combined operation mode	Same as when Pr.340 = "0"
	6	NET operation mode	Switching between the PU and NET operation mode is enabled while running *3, *4
	7	External operation mode	Same as when Pr.340 = "0"

*1 Operation mode can not be directly changed between the PU operation mode and Network operation mode.

*2 The Pr.340 settings "2 or 12" are mainly used for communication operation using the inverter RS-485 terminal.

When a value other than "9999" (selection of automatic restart after instantaneous power failure) is set in Pr.57 **Restart coasting time**, the inverter will resume the same operation state which was in before after power has been restored from an instantaneous power failure. When Pr.340 = "1 or 10", a start command turns off if power failure has occurred and then restored during a start command is on.

*3 Switching between the PU and NET operation modes is available with the key on the operation panel or the X65 signal.

*4 Refer to [page 62](#) for a switching method from the network.

4.3 Operation at communication error occurrence

4.3.1 Operation selection at communication error occurrence (Pr.500 to Pr.502, Pr.779)

You can select operations at communication error occurrences by setting **Pr.500 to Pr.502, Pr.779** under network operation.

◆ **Waiting time for the communication line error output after a communication error**

Waiting time for the communication error output after a communication line error occurrence can be set.

Pr.	Name	Setting range	Minimum setting increments	Initial value
500	Communication error execution waiting time	0 to 999.8 s	0.1 s	0 s

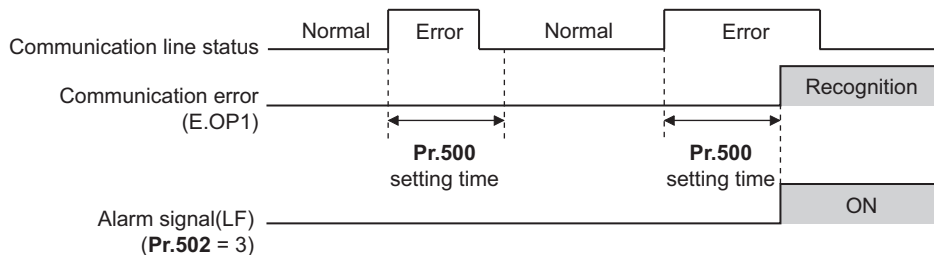

When a communication line error occurs and lasts longer than the time set in **Pr.500**, it is recognized as a communication error. If the communication returns to normal within the time, it is not recognized as a communication error, and the operation continues.

◆ Displaying and clearing the communication error count

The cumulative count of communication error occurrences can be displayed. Write "0" to clear this cumulative count.

Pr.	Name	Setting range	Minimum setting increments	Initial value
501	Communication error occurrence count display	0	1	0

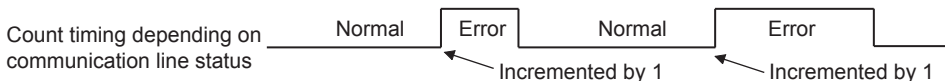

At the point of communication line error occurrence, **Pr.501 Communication error occurrence count display** is incremented by 1.

NOTE

- Communication error count is temporarily stored in the RAM memory. The error count is stored in EEPROM only once per hour. If power reset or converter reset is performed, **Pr.501** setting will be the one that is last stored to EEPROM depending on the reset timing.

◆ Inverter operation at a communication error occurrence

How the inverter operates at a communication line error or an option unit fault can be set.

Pr.	Name	Setting range	Description
502	Stop mode selection at communication error	0 (Initial Value), 1, 2, 3	Refer to page 30
779*1	Operation frequency during communication error	0 to 590 Hz	When a communication error occurs, the inverter operates at the set frequency.
		9999 (Initial Value)	The inverter operates at the frequency set before the communication error occurs.

*1 Valid when **Pr.502** = "3".

◆ About setting

- Operation at an error occurrence

Error definition	Pr.502 setting	Operation	Indication	Fault output
Communication line	0	Continued*1	Normal indication*1	Not provided*1
	1			
	2			
	3			
Communication option itself	0, 3	Coast to stop	E. 1 lit	Provided
	1, 2	Decelerated to stop	E. 1 lit after stop	Provided after stop

*1 When the communication returns to normal within the time period set in **Pr.500**, the communication option error (E.OP1) does not occur.

- Operation after the time in **Pr.500** elapses after an error occurrence

Error definition	Pr.502 setting	Operation	Indication	Fault output
Communication line	0	Coast to stop	E.OP1 lit	Provided
	1	Decelerated to stop	E.OP1 lit after stop	Provided after stop
	2			Not provided
	3	Continues operation with the Pr.779 setting.	Normal indication	
Communication option itself	0, 3	Kept stopped*2	E.OP1 kept lit*2	Kept provided*2
	1, 2			

*2 When an error occurs, the motor is decelerated or coasts to stop, and outputs the fault, independently of the **Pr.500** setting.

- Operation at error removal

Error definition	Pr.502 setting	Operation	Indication	Fault output
Communication line	0	Kept stopped	E.OP1 kept lit	Kept provided
	1			
	2	Restart	Normal indication	Not provided
	3	Normal operation		
Communication option itself	0, 3	Kept stopped	E. 1 kept lit	Kept provided
	1, 2			

NOTE

- The protective function [E.OP1 (fault data: HA1)] is activated at error occurrences on the communication line. The protective function [E.1 (fault data: HF1)] is activated at error occurrences in the communication circuit inside the option.
- Fault output indicates the fault (ALM) signal and fault bit output.
- When the fault output setting is active, fault records are stored in the faults history. (A fault record is written to the faults history at a fault output.)
When the fault output setting is not active, fault record is overwritten to the faults history temporarily but not stored. After the error is removed, the fault indication is reset, changing the display back to normal, and the last fault is displayed in the faults history.
- When the **Pr.502** setting is "1 or 2", the deceleration time is the ordinary deceleration time setting (e.g. **Pr.8**, **Pr.44**, **Pr.45**).
- The acceleration time at a restart is the ordinary acceleration time setting (e.g. **Pr.7**, **Pr.44**).
- When the **Pr.502** setting is "2", the operation/speed command at a restart is the one given before the error occurrence.
- When a communication line error occurs at the **Pr.502** setting of "2", removing the error during deceleration causes acceleration to restart at that point. (Acceleration is not restarted if the error is that of the option unit itself.)
- When **Pr.502** = "3", in order to continue the operation in the case of a communication line error, provide a safety stop countermeasure other than via communication. One counter measure is to input a signal to the terminal RES.

4.3.2 Fault and measures

◆ Inverter operation in each operation mode at error occurrences

Location	Status		Operation mode		
			Network operation	External operation	PU operation
Inverter	Inverter operation		Inverter trip	Inverter trip	Inverter trip
	Data communication		Continued	Continued	Continued
Communication line	Inverter operation		Inverter trip *1	Continued	Continued
	Data communication		Stop	Stop	Stop
Communication option	Communication option connection error	Inverter operation	Inverter trip *1	Inverter trip *1	Inverter trip *1
		Data communication	Continued	Continued	Continued
	Error of communication option itself	Inverter operation	Inverter trip *1	Continued	Continued
		Data communication	Stop	Stop	Stop

*1 Depends on the Pr.502 setting.

◆ Measures at error occurrences

Fault indication	Error definition	Measures
E.OP1	Communication line error	<ul style="list-style-type: none"> • Check the LED status of the option unit and remove the cause of the alarm. (Refer to page 8 for LED indication status) • Inspect the master.
E.1, E.2, E.3	Option fault	<ul style="list-style-type: none"> • Insert the communication option to the inverter option connector 1. • Check the connection between the inverter and option unit for poor contact, etc. and remove the cause of the error.

*1 When faults other than the above are displayed, refer to the Instruction Manual (Detailed) of the inverter and remove the cause of the error.

4.4 Inverter reset

◆ Operation conditions of inverter reset

Which resetting method is allowed or not allowed in each operation mode is described below.

Resetting method			Operation mode		
			Network operation	External operation	PU operation
Reset from the network	Inverter reset (Refer to page 64)*1		Allowed	Disallowed	Disallowed
	Error reset at inverter fault (Refer to page 54)*2	Pr.349 = 0	Allowed	Allowed	Allowed
		Pr.349 = 1		Disallowed	Disallowed
Turn on the inverter RES signal (terminal RES)			Allowed	Allowed	Allowed
Switch off inverter power			Allowed	Allowed	Allowed
Reset from the PU/ DU	Inverter reset		Allowed	Allowed	Allowed
	Reset at inverter fault		Allowed	Allowed	Allowed

*1 Inverter reset can be made any time.

*2 Reset can be made only when the protective function of the inverter is activated.



NOTE

- When a communication line error has occurred, reset cannot be made from the network.
- The inverter is set to the External operation mode if it has been reset in Network operation mode in the initial status. To resume the network operation, the inverter must be switched to the Network operation mode again. Set a value other than "0" in **Pr.340** to start in the Network operation mode. (Refer to [page 25](#).)
- Communication continues during inverter reset. The inverter can not be controlled for about 1 s after release of a reset command.
- Refer to [page 83](#) for an inverter reset program example.

◆ Error reset operation selection at inverter fault

An error reset command from communication option can be invalid in the External operation mode or PU operation mode. Use RY3A for an error reset command from network. (Refer to [page 54](#).)

Pr.	Name	Initial value	Setting range	Function
349	Communication reset selection	0	0	Error reset is enabled independently of operation mode
			1	Error reset is enabled only in the network operation mode

4.5 CC-Link IE Field Network function setting

4.5.1 Network number setting (Pr. 434)

Set the inverter network number in Pr. 434.

Pr.	Name	Initial value	Setting range
434	Network number (CC-Link IE)	0	0 to 255 *1

- *1 The setting range of Pr. 434 is "0 to 255", but its active range is "1 to 239".
The values out of the active range are invalid because such values cannot be transmitted to the master station.



- The setting is applied after an inverter reset or power-ON.

4.5.2 Station number setting (Pr. 435)

Use Pr. 435 to set station number of the inverter.

Pr.	Name	Initial value	Setting range
435	Station number (CC-Link IE)	0	0 to 255 *1

- *1 The setting range of Pr. 435 is "0 to 255", but its active range is "1 to 120".
The values out of the active range are invalid because such values cannot be transmitted to the master station.



- Use different station numbers for different devices. (If different devices have the same station number, the communication cannot be performed properly. If an error occurs due to a duplicated number, re-assign the station numbers, then reset the master station or the inverter power.)
- Station numbers do not have to be consecutive numbers.
- The setting is applied after an inverter reset or power-ON.

4.5.3 Frequency command with sign (Pr. 541)

By frequency command with sign, start command (forward rotation/reverse rotation) can be inverted to operate. Make selection of sign for the frequency command from RWw0.

Pr.	Name	Initial value	Setting range
541	Frequency command sign selection	0	0, 1

Speed setting using Pr.37 and Pr.144	Pr.541 setting	Sign	Setting range	Actual frequency command
Not used	0	Not used	0 to 59000	0 to 590.00 Hz
	1	With	-32768 to 32767 (two's complement)	-327.68 to 327.67 Hz
With	0	Not used	0 to 65535	It depends on Pr. 37, Pr. 144, Pr. 811*1. (in 1 or 0.1 increments)
	1	With	-32768 to 32767 (two's complement)	

*1 The setting is available only for the FR-A800 series.

- Relationship between the start command and sign (Pr. 541 = "1")

Start command	Sign of the frequency command	Actual run command
Forward rotation	+	Forward rotation
	-	Reverse rotation
Reverse rotation	+	Reverse rotation
	-	Forward rotation

 **NOTE**

- When **Pr. 541** = 1 (with sign)
 - When EEPROM write is specified with the RY22, write mode error (error code H01) will occur.
 - When both RY21 and RY22 are turned ON, RY21 has precedence.
 - When power is turned ON (inverter reset), the initial setting status of the sign bit is "positive" and the set frequency is "0 Hz". (The motor does not operate at the frequency set before turning OFF the power (inverter reset).)
 - When set frequency is written with the instruction code of HED and HEE, the sign of the frequency command is not changed.
- Setting "1 or 11" in **Pr.811 Set resolution switchover** changes the increments from 1 r/min to 0.1 r/min. (Only for the FR-A800 series)

5 FUNCTION OVERVIEW

5.1 Output from the inverter through the network

Main items which can be output from the inverter to the master and their descriptions are explained below.

Item	Description	Refer to page
Inverter status monitor	The output terminal status of the inverter can be monitored.	55
Output frequency monitor	The output frequency can be monitored.	61, 62
Output current monitor	The output current can be monitored.	62
Output voltage monitor	The output voltage can be monitored.	62
Special monitor	The monitor data selected can be checked.	62
Faults history	Fault records can be checked.	60, 63
Data at alarm occurrence	The inverter status at alarm occurrence can be checked.	60
Operation Mode	The current operation mode can be checked.	62
Parameter read	Parameter settings can be read.	64
Read of set frequency	The current set frequency can be read.	63



- Refer to the Instruction Manual (Detailed) of the inverter for functions controllable through the network in each operation mode.

5.2 Input to the inverter through the network

Main commands which can be input from the master to the inverter and their descriptions are explained below.

Item	Description	Refer to page
Forward rotation command	Give the forward rotation command.	52
Reverse rotation command	Give the reverse rotation command.	52
Input terminal function command	Execute functions assigned to the inverter input terminals.	53
Inverter output stop command	Stop the inverter output.	53
Error reset	Reset the inverter only when an inverter alarm occurs.	54
Frequency setting	Set the frequency.	57, 63
Torque command / torque limit *1	Set the torque command or the torque limit.	57, 67
Monitor command	Specify the description monitored.	61, 62
Operation mode specification	Set the operation mode.	62
Faults history clear	Erase past eight fault records.	64
All parameter clear	Return the parameter descriptions to the initial value.	64
Inverter reset	Reset the inverter.	64
Parameter write	Write parameter settings.	64
PID control	PID set point, PID measured value and PID deviation can be input from the network.	57

*1 The setting is available only for the FR-A800 series.



- Refer to the Instruction Manual (Detailed) of the inverter for functions controllable through the network in each operation mode.

5.3 Cyclic transmission

Data communication is available periodically among stations on the same network. Link devices (RX, RY, RWr, and RWw) are used.

5.3.1 Data flow and link device assignment

◆ Master and slave stations (except for local stations)

One-to-one communication is possible between the master and slave stations.

The status information of the link devices (RY and RWw) of the master station is output to the external device of the slave station, and the input status information from the external device of the slave station is stored in the link devices (RX and RWr) of the master station.

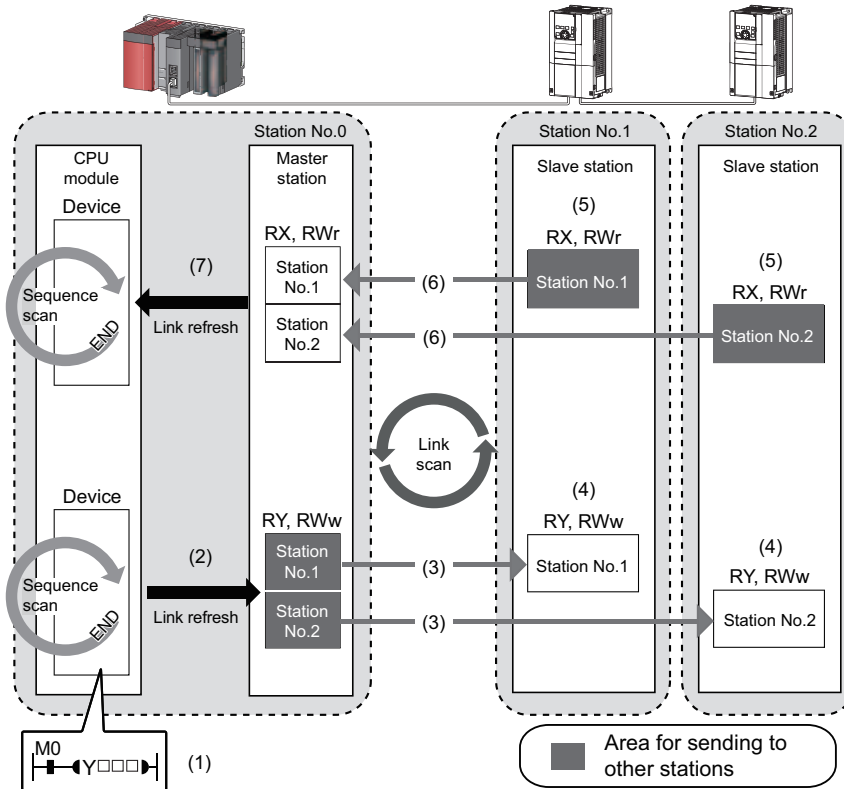

- Output from the master station
 - (1) The device of the CPU module turns ON.
 - (2) The device status data of the CPU module are stored in the link devices (RY and RWw) of the master station by link refresh.
 - (3) The status data of the link devices (RY and RWw) of the master station are stored in the link devices (RY and RWw) of each slave station by link scan.
 - (4) The inverter starts according to the link device (RY and RWw) conditions (input signals such as STF and STR) of the slave station.

- Input from the slave station
 - (5) Inverter conditions (output signals such as RUN and SU, monitoring) are stored in the link devices (RX and RWr) of the slave station.
 - (6) The status data of the link devices (RX and RWr) of the slave station are stored in the link devices (RX and RWr) of the master station by link scan.
 - (7) The status data of the link devices (RX and RWr) of the master station are stored in the devices of the CPU module by link refresh.

 **NOTE**

- Refer to the MELSEC iQ-R, MELSEC-Q, or MELSEC-L CC-Link IE Field Network Master/Local Module User's Manual for the detailed assignment methods for the link devices and link refresh.

6 I/O SIGNAL LIST

6.1 Remote I/O (64 points fixed)

Device No. *6	Signal	Refer to page
RYn0	Forward rotation command *3	52
RYn1	Reverse rotation command *3	52
RYn2	High-speed operation command (terminal RH function) *1	53
RYn3	Middle-speed operation command (terminal RM function) *1	53
RYn4	Low-speed operation command (terminal RL function) *1	53
RYn5	Jog operation command (terminal Jog function) *1	53
RYn6	Second function selection (terminal RT function) *1	53
RYn7	Current input selection (terminal AU function) *1	53
RYn8	Selection of automatic restart after instantaneous power failure (terminal CS function) *1, *2	53

Device No. *6	Signal	Refer to page
RXn0	Forward running	55
RXn1	Reverse running	55
RXn2	Running (terminal RUN function) *4	55
RXn3	Up to frequency (terminal SU function) *4	55
RXn4	Overload alarm (terminal OL function) *4	55
RXn5	Instantaneous power failure (terminal IPF function) *4	55
RXn6	Frequency detection (terminal FU function) *4	55
RXn7	Error (terminal ABC1 function) *4	55
RXn8	— (terminal ABC2 function) *4	55

Device No. *6	Signal	Refer to page
RYn9	Output stop (terminal MRS function) *1	53
RYnA	Start self-holding selection (terminal STOP function) *1	53
RYnB	Reset (terminal RES function) *1	53
RYnC to RYnF	Reserved	—
RY(n+1)0 to RY(n+1)2		
RY(n+1)3 to RY(n+1)F	Reserved	—
RY(n+2)0	Monitor command	54
RY(n+2)1	Frequency setting command (RAM)	54
RY(n+2)2	Frequency setting command (RAM, EEPROM)	54
RY(n+2)3	Torque command / torque limit (RAM) *7	54
RY(n+2)4	Torque command / torque limit (RAM, EEPROM) *7	54
RY(n+2)5	Instruction code execution request	54
RY(n+2)6 to RY(n+3)9	Reserved	—
RY(n+3)A	Error reset request flag	54

Device No. *6	Signal	Refer to page
RXn9 to RXnF	Reserved	—
RX(n+1)0	Pr.313 assignment function (DO0) *5	55
RX(n+1)1	Pr.314 assignment function (DO1) *5	55
RX(n+1)2	Pr.315 assignment function (DO2) *5	55
RX(n+1)3 to RX(n+1)F	Reserved	—
RX(n+2)0	Monitoring	56
RX(n+2)1	Frequency setting completion (RAM)	56
RX(n+2)2	Frequency setting completion (RAM, EEPROM)	56
RX(n+2)3	Torque command / torque limit setting completion (RAM) *7	56
RX(n+2)4	Torque command / torque limit setting completion (RAM, EEPROM) *7	56
RX(n+2)5	Instruction code execution completion	56
RX(n+2)6 to RX(n+3)9	Reserved	—
RX(n+3)A	Error status flag	56

Device No. *6	Signal	Refer to page
RY(n+3)B to RY(n+3)F	Reserved	—

Device No. *6	Signal	Refer to page
RX(n+3)B	Remote station ready	56
RX(n+3)C to RX(n+3)F	Reserved	—

- *1 These signals are set in the initial values. Using **Pr. 180 to Pr. 189**, you can change input signal functions. Refer to the Instruction Manual (Detailed) of the inverter for details of **Pr. 180 to Pr. 189**.
- *2 For the FR-F800 series, no function is assigned in the initial setting.
- *3 The signals are fixed. They cannot be changed using parameters.
- *4 These signals are set in the initial values. Using **Pr. 190 to Pr. 196**, you can change output signal functions. Refer to the Instruction Manual (Detailed) of the inverter for details of **Pr. 190 to Pr. 196**.
- *5 Output signal can be assigned using **Pr. 313 to Pr. 315**.
The settings of **Pr.313 to Pr.315** are the same as those of **Pr.190 to Pr.196 (output terminal function selection)**. Refer to the Instruction Manual (Detailed) of the inverter for details of **Pr. 190 to Pr. 196**.
- *6 "n" indicates a value determined according to the station number setting.
- *7 The signal is valid only for the FR-A800 series.

6.2 Remote register (128 words fixed)

Address *5	Description		Refer to page	Address *5	Description		Refer to page
	Upper 8 bits	Lower 8 bits			Upper 8 bits	Lower 8 bits	
RWwn	Set frequency (0.01 Hz increments)		57	RWrn	Reply code		59
RWwn+1	Reserved		—	RWrn+1	Reserved		—
RWwn+2	Torque command / torque limit *1, *2		57	RWrn+2	Reply code *1		59
RWwn+3	Reserved		—	RWrn+3	Reserved		—
RWwn+4	PID set point (0.01% increments) *3		57	RWrn+4	Reply code		59
RWwn+5	PID measured value (0.01% increments) *3		57	RWrn+5	Reply code		59
RWwn+6	PID deviation (0.01% increments) *3		57	RWrn+6	Reply code		59
RWwn+7 to RWwn+F	Reserved		—	RWrn+7 to RWrn+F	Reserved		—
RWwn+10	Link parameter extended setting	Instruction code *4	57	RWrn+10	Reply code		60
RWwn+11	Write data		58	RWrn+11	Read data *4		60
RWwn+12	Link parameter extended setting	Instruction code *4	57	RWrn+12	Reply code		60
RWwn+13	Write data		58	RWrn+13	Read data *4		60
RWwn+14	Link parameter extended setting	Instruction code *4	57	RWrn+14	Reply code		60
RWwn+15	Write data		58	RWrn+15	Read data *4		60
RWwn+16	Link parameter extended setting	Instruction code *4	57	RWrn+16	Reply code		60
RWwn+17	Write data		58	RWrn+17	Read data *4		60

Address *5	Description		Refer to page
	Upper 8 bits	Lower 8 bits	
RWwn+18	Link parameter extended setting	Instruction code *4	57
RWwn+19	Write data		58
RWwn+1A	Link parameter extended setting	Instruction code *4	57
RWwn+1B	Write data		58
RWwn+1C to RWwn+1F	Reserved		—
RWwn+20	Reserved		—
RWwn+21	Faults history No.		58
RWwn+22 to RWwn+25	Reserved		—
RWwn+26	Monitor code 1		58
RWwn+27	Monitor code 2		58
RWwn+28	Monitor code 3		58
RWwn+29	Monitor code 4		58
RWwn+2A	Monitor code 5		58
RWwn+2B	Monitor code 6		58
RWwn+2C	Monitor code 7		58
RWwn+2D	Monitor code 8		58

Address *5	Description		Refer to page
	Upper 8 bits	Lower 8 bits	
RWrn+18	Reply code		60
RWrn+19	Read data *4		60
RWrn+1A	Reply code		60
RWrn+1B	Read data *4		60
RWrn+1C to RWrn+1F	Reserved		—
RWrn+20	Error status		60
RWrn+21	Faults history No.	Fault record (fault data)	60
RWrn+22	Fault record (output frequency)		60
RWrn+23	Fault record (output current)		60
RWrn+24	Fault record (output voltage)		60
RWrn+25	Fault record (energization time)		61
RWrn+26	First monitor value		61
RWrn+27	Second monitor value		61
RWrn+28	Third monitor value		61
RWrn+29	Fourth monitor value		61
RWrn+2A	Fifth monitor value		61
RWrn+2B	Sixth monitor value		61
RWrn+2C	Seventh monitor value		61
RWrn+2D	Eighth monitor value		61

Address *5	Description		Refer to page	Address *5	Description		Refer to page
	Upper 8 bits	Lower 8 bits			Upper 8 bits	Lower 8 bits	
RWwn+2E	Monitor code 9		58	RWrn+2E	Ninth monitor value		61
RWwn+2F	Monitor code 10		58	RWrn+2F	Tenth monitor value		61
RWwn+30 to RWwn+40	Reserved		—	RWrn+30	Output frequency		61
				RWrn+31	Reserved		—
				RWrn+32	output current		61
				RWrn+33	output voltage		61
				RWrn+34	Reserved		—
				RWrn+35	Frequency setting value		61
				RWrn+36	Running speed		61
				RWrn+37	Motor torque		61
				RWrn+38	Converter output voltage		61
				RWrn+39	Regenerative brake duty		61
				RWrn+3A	Electric thermal relay function load factor		61
				RWrn+3B	Output current peak value		61
				RWrn+3C	Converter output voltage peak value		61
				RWrn+3D	Input power		61
				RWrn+3E	Output power		61
				RWrn+3F	Input terminal status		61
				RWrn+40	Output terminal status		61

Address *5	Description		Refer to page
	Upper 8 bits	Lower 8 bits	
RWwn+41 to RWwn+53	Reserved		—

Address *5	Description		Refer to page
	Upper 8 bits	Lower 8 bits	
RWwn+41	Load meter		61
RWwn+42	Motor excitation current		61
RWwn+43	Position pulse *1		61
RWwn+44	Cumulative energization time		61
RWwn+45	Reserved		—
RWwn+46	Orientation status *1		61
RWwn+47	Actual operation time		61
RWwn+48	Motor load factor		61
RWwn+49	Cumulative power		61
RWwn+4A	Position command (lower digits) *1		61
RWwn+4B	Position command (upper digits) *1		61
RWwn+4C	Current position (lower digits) *1		61
RWwn+4D	Current position (upper digits) *1		61
RWwn+4E	Droop pulse (lower digits) *1		61
RWwn+4F	Droop pulse (upper digits) *1		61
RWwn+50	Torque command *1		61
RWwn+51	Torque current command *1		61
RWwn+52	Motor output		61
RWwn+53	Feedback pulse *1		61

Address *5	Description		Refer to page
	Upper 8 bits	Lower 8 bits	
RWwn+54 to RWwn+6C	Reserved		—
	RWrn+54	Reserved	—
	RWrn+55		—
	RWrn+56	Trace status	61
	RWrn+57	Reserved	—
	RWrn+58	PLC function user monitor 1	61
	RWrn+59	PLC function user monitor 2	61
	RWrn+5A	PLC function user monitor 3	61
	RWrn+5B	Station number (RS-485 terminals)	61
	RWrn+5C	Station number (PU)	61
	RWrn+5D	Station number (CC-Link)	61
	RWrn+5E to RWrn+61	Reserved	—
	RWrn+62	Power saving effect	61
	RWrn+63	Cumulative saving power	61
	RWrn+64	PID set point	61
	RWrn+65	PID measured value	61
	RWrn+66	PID deviation	61
	RWrn+67 to RWrn+69	Reserved	—
	RWrn+6A	Option input terminal status 1	61
	RWrn+6B	Option input terminal status 2	61
	RWrn+6C	Option output terminal status	61

Address *5	Description		Refer to page
	Upper 8 bits	Lower 8 bits	
RWwn+6D to RWwn+7F	Reserved		—

Address *5	Description		Refer to page
	Upper 8 bits	Lower 8 bits	
RWwn+6D	Motor thermal load factor		61
RWwn+6E	Inverter thermal load factor		61
RWwn+6F	Reserved		—
RWwn+70	PTC thermistor value		61
RWwn+71	Reserved		—
RWwn+72			
RWwn+73	PID measured value 2		61
RWwn+74	Emergency drive status *6		61
RWwn+75	Reserved		—
RWwn+76			
RWwn+77	Cumulative pulse *1		61
RWwn+78	Cumulative pulse carrying-over times *1		61
RWwn+79	Cumulative pulse (control terminal option) *1		61
RWwn+7A	Cumulative pulse carrying-over times (control terminal option) *1		61
RWwn+7B to RWwn+7F	Reserved		—

*1 Valid only for the FR-A800 series.

*2 The torque limit is available only when the inverter supports this function. (Refer to [page 67](#).)

*3 When **Pr. 128** = "50, 51, 60, 61", they are valid.

*4 Instructions will be processed in the order they are received. Thus, the read value of an instruction may differ at different timings if other writing requests are being made.

*5 "n" indicates a value determined according to the station number setting.

*6 Valid only for the FR-F800 series.

7 DETAILS OF I/O SIGNALS

The following device No. are those for station 1.

For stations 2 and later, the device No. are different. (Refer to the master module manual for correspondence between the device No. and station number)

7.1 Details of remote input and output signals

7.1.1 Output signals (master module to inverter (FR-A8NCE))

The output signals from the master module are indicated. (Input signals to inverter)

Device No.	Signal	Description	
RY0	Forward rotation command	0: Stop command 1: Forward rotation start	• When "1" is set, a start command is input to the inverter. When "1" is set in RY0 and RY1, a stop command is input. • The signals are fixed. They cannot be changed using parameters.
RY1	Reverse rotation command	0: Stop command 1: Reverse rotation start	

Device No.	Signal	Description
RY2	High-speed operation command (terminal RH function)	<ul style="list-style-type: none"> • Functions assigned to terminals RH, RM, RL, JOG, RT, AU, CS, MRS, STOP and RES are activated. • Signal names are initial values. Using Pr.180 to Pr.189, you can change input signal functions. Note that some of signals do not accept a command from the network according to the Pr.338 and Pr.339 settings. For example, RYB reset (terminal RES function) cannot be controlled via network. Refer to the Instruction Manual (Detailed) of the inverter for the details of Pr.180 to Pr.189, Pr.338, and Pr.339.
RY3	Middle-speed operation command (terminal RM function)	
RY4	Low-speed operation command (terminal RL function)	
RY5	Jog operation command (terminal JOG function)	
RY6	Second function selection (terminal RT function)	
RY7	Current input selection (terminal AU function)	
RY8	Selection of automatic restart after instantaneous power failure (terminal CS function) *1	
RY9	Output stop (terminal MRS function)	
RYA	Start self-holding selection (terminal STOP function)	
RYB	Reset (RES terminal function)	

Device No.	Signal	Description
RY20	Monitor command	When "1" is set in the monitor command (RY20), the monitored value is set in the remote register RWr26 to RWr2F, and "1" is set in the monitoring (RX20). While "1" is set in the monitor command (RY20), the monitored data is always updated.
RY21	Frequency setting command (RAM)	When "1" is set in the frequency setting command (RY21), the set frequency (RWw0) is written to RAM of the inverter. While "1" is set, the set frequency (RWw0) is always applied. After the writing completes, "1" is set in the frequency setting completion (RX21).
RY22	Frequency setting command (RAM, EEPROM)	When "1" is set in the frequency setting command (RY22), the set frequency (RWw0) is written to RAM and EEPROM of the inverter. After the writing completes, "1" is set in the frequency setting completion (RX22). To change the frequency consecutively, be sure to write data only to the inverter RAM.
RY23	Torque command / torque limit (RAM) *2	When "1" is set in the torque command / torque limit (RY23), the set torque command / torque limit (RWw2) is written to RAM of the inverter. After the writing completes, "1" is set in the torque command / torque limit setting completion (RX23). The following value is written to RAM. • During torque control *3: Torque command value • During speed control / position control: Torque limit value
RY24	Torque command / torque limit (RAM, EEPROM) *2	When "1" is set in the torque command / torque limit (RY24), the set torque command / torque limit (RWw2) is written to RAM and EEPROM of the inverter. After the writing completes, "1" is set in the torque command / torque limit setting completion (RX24). The following value is written to RAM and EEPROM. • During torque control *3: Torque command value • During speed control / position control: Torque limit value To change the torque command or the torque limit consecutively, be sure to write data to the inverter RAM.
RY25	Instruction code execution request	When "1" is set in the instruction code execution request (RY25), processes corresponding to the instruction codes set to RWw10, 12, 14, 16, 18 and 1A are executed. "1" is set in the instruction code execution request (RX25) after completion of instruction codes. When an instruction code execution error occurs, a value other than "0" is set in the reply code (RWr10, 12, 14, 16, 18 and 1A).
RY3A	Error reset request flag	When "1" is set in the error reset request flag (RY3A) at an inverter fault, the inverter is reset, then "0" is set in the error status flag (RX3A). Refer to page 33 for operation conditions of inverter reset.

*1 For the FR-F800 series, no function is assigned in the initial setting.

*2 The signal is valid only for the FR-A800 series.

*3 Torque control cannot be performed with a PM motor.

7.1.2 Input signals (inverter (FR-A8NCE) to master module)

The input signals to the master module are indicated. (Output signals from inverter)

Device No.	Signal	Description
RX0	Forward running	0 : Other than forward running (during stop or reverse rotation) 1 : Forward running
RX1	Reverse running	0 : Other than reverse running (during stop or forward rotation) 1 : Reverse running
RX2	Running (terminal RUN function)	<ul style="list-style-type: none"> • Functions assigned to terminals RUN, SU, OL, IPF, FU, ABC1 and ABC2 activate. • Signal names are initial values. Using Pr.190 to Pr.196, you can change output signal functions. Refer to the Instruction Manual (Detailed) of the inverter for details of Pr.190 to Pr.196.
RX3	Up to frequency (terminal SU function)	
RX4	Overload alarm (terminal OL function)	
RX5	Instantaneous power failure (terminal IPF function)	
RX6	Frequency detection (terminal FU function)	
RX7	Fault (terminal ABC1 function)	
RX8	— (terminal ABC2 function)	
RX10	— (DO0 function)	<ul style="list-style-type: none"> • Functions assigned to Pr.313 to Pr.315 are activated. • No signal is assigned in the initial setting. Use Pr.313 to Pr.315 to assign signals to the devices RX10 to RX12. The settings of Pr.313 to Pr.315 are the same as those of Pr.190 to Pr.196 (output terminal function selection). Refer to the Instruction Manual (Detailed) of the inverter for details of Pr.190 to Pr.196.
RX11	— (DO1 function)	
RX12	— (DO2 function)	

Device No.	Signal	Description
RX20	Monitoring	After "1" is set in the monitor command (RY20), and the monitored value is set in the remote register RWr26 to RWr2F, "1" is set in this signal. When "0" is set in the monitor command (RY20), "0" is set in this signal.
RX21	Frequency setting completion (RAM)	After "1" is set in the frequency setting command (RY21) and the set frequency is written to the inverter RAM, "1" is set in this signal. When "0" is set in the frequency setting command (RY21), "0" is set in this signal.
RX22	Frequency setting completion (RAM, EEPROM)	After "1" is set in the frequency setting command (RY22) and the set frequency is written to the inverter RAM and EEPROM, "1" is set in this signal. When "0" is set in the frequency setting command (RY22), "0" is set in this signal.
RX23	Torque command / torque limit setting completion (RAM) *1	After "1" is set in the torque command / torque limit (RY23) and the torque command / torque limit value is written to the inverter RAM, "1" is set in this signal. When "0" is set in the torque command / torque limit (RY23), "0" is set in this signal.
RX24	Torque command / torque limit setting completion (RAM, EEPROM) *1	After "1" is set in the torque command / torque limit (RY24) and the torque command / torque limit value is written to the inverter RAM and EEPROM, "1" is set in this signal. When "0" is set in the torque command / torque limit (RY24), "0" is set in this signal.
RX25	Instruction code execution completion	After "1" is set in the instruction code execution request (RY25) and the processes corresponding to the instruction codes (RWw10, 12, 14, 16, 18 and 1A) are executed, "1" is set in this signal. When "0" is set in the instruction code execution request (RY25), "0" is set in this signal.
RX3A	Error status flag	When an inverter error occurs (protective function is activated), "1" is set in this signal.
RX3B	Remote station ready	When the inverter goes into the ready status upon completion of initial setting after power-ON or hardware reset, "1" is set in this signal. When an inverter error occurs (protective function is activated), "0" is set in this signal. The signal is used as an interlock signal during the write to/read from the master module.

*1 The signal is valid only for the FR-A800 series.

7.2 Details of remote register

7.2.1 Remote register (master module to inverter (FR-A8NCE))

◆ Remote register definition

Device No.	Signal	Description
RWw0	Set frequency *1, *2	<ul style="list-style-type: none"> Specify the set frequency or rotations per minute (machine speed). At this time, whether to write to RAM or EEPROM is decided with the RY21 and RY22 settings. After setting the set frequency in this register, set "1" in RY21 or RY22 to write the frequency. After writing of frequency is completed, "1" is set in RX21 or RX22 in response to the input command. The setting range is 0 to 590.00 Hz (0.01 Hz increments). Write "59000" when setting 590.00 Hz.
RWw2 *5, *6	Torque command value	Specify the torque command value / torque limit value. Set Pr.804 Torque command source selection = "1, 3, 5, or 6" to activate this signal under Real sensorless vector control, vector control, and PM sensorless vector control. The value is written to the inverter either by RY23 or RY24. Pr.805 Torque command value (RAM) and Pr.806 Torque command value (RAM,EEPROM) are updated as well. The setting range and setting increments depend on the Pr.804 setting. (Refer to page 67)
	Torque limit value *7	
RWw4	PID set point *3	Set the PID set point Setting range: "0 to 100.00%"
RWw5	PID measured value *3	Set the PID measured value Setting range: "0 to 100.00%"
RWw6	PID deviation *3	Set the PID deviation. Setting range: "-100.00% to 100.00%"
RWw10, RWw12, RWw14, RWw16, RWw18, RWw1A	Link parameter extended setting/ Instruction code	<p>Set an instruction code (refer to page 62) for an operation such as operation mode switching, parameter read/write, alarm reference, and alarm clear in the lower eight bits. The instructions are executed in the following order by setting "1" in RY25 after completing the register setting: RWw10, 12, 14, 16, 18, then 1A. After completing the execution up to RWw1A, "1" is set in RX25. Set HFFFF to disable an instruction by RWw10 to 1A.</p> <p>Set the link parameter extended setting in the upper eight bits.</p> <p>Example) When reading Pr.160, instruction code is H0200.</p>

Device No.	Signal	Description
RWw11, RWw13, RWw15, RWw17, RWw19, RWw1B	Write data	Set the data specified by the instruction code of RWw10, 12, 14, 16, 18 and 1A. (when required) RWw10 and 11, 12 and 13, 14 and 15, 16 and 17, 18 and 19, and 1A and 1B correspond each other. Set "1" in RY25 after setting the instruction codes (RWw10, 12, 14, 16, 18 and 1A) and the corresponding register. Set "0" when the write code is not required.
RWw21	Faults history No. *4	Set the number of previous faults you want to be able to read in the faults history. Up to 8 previous faults can be read. Last two digits: H00 (most recent fault) to H07 (8th most recent fault) Set H08 to HFF to make the faults history No. to "0."
RWw26	Monitor code 1 *4	Set the monitor code to be monitored. (Refer to page 66) By setting "1" in RY20 after setting, the specified monitored data is stored in RWw26 to RWw2F. If a monitor code out of the setting range is set, no item is monitored (the monitor value is fixed to 0).
RWw27	Monitor code 2 *4	
RWw28	Monitor code 3 *4	
RWw29	Monitor code 4 *4	
RWw2A	Monitor code 5 *4	
RWw2B	Monitor code 6 *4	
RWw2C	Monitor code 7 *4	
RWw2D	Monitor code 8 *4	
RWw2E	Monitor code 9 *4	
RWw2F	Monitor code 10 *4	

- *1 Setting increment differs according to the combination of **Pr.37**, **Pr.144**, and **Pr.811**. (**Pr.811** is only available for the FR-A800 series.) Refer to the Instruction Manual (Detailed) of the inverter for the details.
- *2 When **Pr.541 Frequency command sign selection** = "1", the setting value has either + or -. When the setting value is negative, the command is the inverse from the command.
Setting range: -327.68 Hz to 327.67 Hz (-327.68 to 327.67) 0.01 Hz increments.
For details refer to [page 36](#).
- *3 When **Pr.128** = "50, 51, 60, 61", they are valid. If the data outside the range is set, the previous setting is retained.
Refer to the Instruction Manual (Detailed) of the inverter for details of **Pr.128**.
- *4 Write data is in hexadecimal, and only two digits are valid. (The upper two digits are ignored.)
- *5 The signal is valid only for the FR-A800 series.
- *6 The value in RWw2 is used as the torque limit value during speed control or position control, and as the torque command value during torque control. (Torque control cannot be performed with a PM motor.) To use the value as the torque limit value, set **Pr.810** = "2".
- *7 This setting is available only when the inverter supports this function. (Refer to [page 67](#).)

7.2.2 Remote register (inverter (FR-A8NCE) to master module)

◆ Remote register definition

Device No.	Signal	Description								
RWr0	Reply code	When "1" is set in RY21 or RY22, the following reply codes are set for the frequency setting command. The setting value "0" is set normally, and a value other than "0" is set at an error.								
		<table border="1"> <thead> <tr> <th>Value</th> <th>Description</th> </tr> </thead> <tbody> <tr> <td>H0000</td> <td>Normal</td> </tr> <tr> <td>H0001</td> <td>Write mode fault</td> </tr> <tr> <td>H0003</td> <td>Setting range fault</td> </tr> </tbody> </table>	Value	Description	H0000	Normal	H0001	Write mode fault	H0003	Setting range fault
		Value	Description							
		H0000	Normal							
H0001	Write mode fault									
H0003	Setting range fault									
RWr2	Reply code *1	When "1" is set in RY23 or RY24, the following reply codes are set for the torque command / torque limit. The setting value "0" is set normally, and a value other than "0" is set at an error.								
		<table border="1"> <thead> <tr> <th>Value</th> <th>Description</th> </tr> </thead> <tbody> <tr> <td>H0000</td> <td>Normal</td> </tr> <tr> <td>H0003</td> <td>Setting range fault</td> </tr> </tbody> </table>	Value	Description	H0000	Normal	H0003	Setting range fault		
		Value	Description							
		H0000	Normal							
H0003	Setting range fault									
RWr4, RWr5, RWr6	Reply code	When the PID command (RWr4 to RWr6) is set, the following reply code is set for the PID command. The setting value "0" is set normally, and a value other than "0" is set at an error.								
		<table border="1"> <thead> <tr> <th>Value</th> <th>Description</th> </tr> </thead> <tbody> <tr> <td>H0000</td> <td>Normal</td> </tr> <tr> <td>H0003</td> <td>Setting range fault</td> </tr> </tbody> </table>	Value	Description	H0000	Normal	H0003	Setting range fault		
		Value	Description							
		H0000	Normal							
H0003	Setting range fault									

Device No.	Signal	Description										
RWr10, RWr12, RWr14, RWr16, RWr18, RWr1A	Reply code	<p>When "1" is set in RY25, the following reply codes corresponding to the instruction code RWw10, 12, 14, 16, 18, and 1A are set. The setting value "0" is set normally, and a value other than "0" is set at an error.</p> <table border="1"> <thead> <tr> <th>Value</th> <th>Description</th> </tr> </thead> <tbody> <tr> <td>H0000</td> <td>Normal</td> </tr> <tr> <td>H0001</td> <td>Write mode fault</td> </tr> <tr> <td>H0002</td> <td>Parameter selection fault</td> </tr> <tr> <td>H0003</td> <td>Setting range fault</td> </tr> </tbody> </table>	Value	Description	H0000	Normal	H0001	Write mode fault	H0002	Parameter selection fault	H0003	Setting range fault
Value	Description											
H0000	Normal											
H0001	Write mode fault											
H0002	Parameter selection fault											
H0003	Setting range fault											
RWr11, RWr13, RWr15, RWr17, RWr19, RWr1B	Read data	For a normal reply, the reply data to the instruction specified by the instruction code is set.										
RWr20	Error status	The setting value "0" is set during normal inverter operation, and the data code of the corresponding error is set at an error. (For the data codes or details of fault records, refer to the Instruction Manual (Detailed) of the inverter.)										
RWr21	Fault record (fault data)	The data code of faults history No. specified by RWw21 is stored in the lower 8bits. Lower 8 bits of RWw21 will be reverted back to the upper 8 bits.										
RWr22	Fault record (output frequency)	Output frequency of the faults history No. specified in RWw21 is stored.										
RWr23	Fault record (output current)	Output current of the faults history No. specified in RWw21 is stored.										
RWr24	Fault record (output voltage)	Output voltage of the faults history No. specified in RWw21 is stored.										

Device No.	Signal	Description
RWr25	Fault record (energization time)	Energization time of the faults history No. specified in RWw21 is stored.
RWr26	First monitor value	When "1" is set in RY20, the monitored data specified by the monitor code RWw26 to RWw2F is saved. Output frequency, output current, and output voltage monitors are held at an inverter failure.
RWr27	Second monitor value	
RWr28	Third monitor value	
RWr29	Fourth monitor value	
RWr2A	Fifth monitor value	
RWr2B	Sixth monitor value	
RWr2C	Seventh monitor value	
RWr2D	Eighth monitor value	
RWr2E	Ninth monitor value	
RWr2F	Tenth monitor value	
RWr30 to RWr7F	Monitor value	Fixed monitored data are saved regardless of the RY20 setting. Output frequency, output current, and output voltage monitors are held at an inverter failure.

*1 The signal is valid only for the FR-A800 series.

7.2.3 Instruction codes

◆ Instruction code definition

Set the instruction code using a remote register (RWw) (Refer to [page 57](#).)

The definition read by the instruction code is stored in the remote register (RWr). (Refer to [page 59](#).)

Item		Read/ write	Code number	Description
Operation mode		Read	H7B	H0000: Network operation mode H0001: External operation mode, External JOG operation mode H0002: PU operation mode, External/PU combined operation modes 1 and 2, PUJOG operation mode
		Write	HFB	H0000: Network operation mode H0001: External operation mode H0002: PU operation mode (Pr.79 = "6", Pr.340 = "10, 12")
Monitor	Output frequency *1, *2	Read	H6F	H0000 to HFFFF: Running frequency: 0.01 Hz increments Speed (machine speed): 1 increments *3
	Output current	Read	H70	H0000 to HFFFF: Output current (hexadecimal): Increments 0.01 A/0.1 A *5
	Output voltage	Read	H71	H0000 to HFFFF: Output voltage (hexadecimal): Increments 0.1 V
	Special monitor	Read	H72	H0000 to HFFFF: Check the data of the monitor selected by the instruction code HF3.
	Special monitor selection No.	Read	H73	H01 to HFF: Selection of the monitored item (monitor code) (Refer to page 66 .) If a monitor code out of the range is set, a range error occurs.
Write		HF3 *4		

Item		Read/write	Code number	Description																								
Monitor	Faults history	Read	H74 to H77	<p>H0000 to HFFFF: Last two fault records</p> <p>b15 b8 b7 b0</p> <p>H74 <table border="1" style="display: inline-table; vertical-align: middle;"><tr><td style="width: 100px;">Second fault in past</td><td style="width: 100px;">Latest fault</td></tr></table></p> <p>H75 <table border="1" style="display: inline-table; vertical-align: middle;"><tr><td style="width: 100px;">Fourth fault in past</td><td style="width: 100px;">Third fault in past</td></tr></table></p> <p>H76 <table border="1" style="display: inline-table; vertical-align: middle;"><tr><td style="width: 100px;">Sixth fault in past</td><td style="width: 100px;">Fifth fault in past</td></tr></table></p> <p>H77 <table border="1" style="display: inline-table; vertical-align: middle;"><tr><td style="width: 100px;">Eighth fault in past</td><td style="width: 100px;">Seventh fault in past</td></tr></table></p> <p>For instruction code H74, read data H30A0</p> <p>b15 b8 b7 b0</p> <table border="1" style="display: inline-table; vertical-align: middle;"> <tr> <td style="width: 20px;">0</td><td style="width: 20px;">0</td><td style="width: 20px;">1</td><td style="width: 20px;">1</td><td style="width: 20px;">0</td><td style="width: 20px;">0</td><td style="width: 20px;">0</td><td style="width: 20px;">0</td><td style="width: 20px;">1</td><td style="width: 20px;">0</td><td style="width: 20px;">1</td><td style="width: 20px;">0</td><td style="width: 20px;">0</td><td style="width: 20px;">0</td><td style="width: 20px;">0</td><td style="width: 20px;">0</td> </tr> </table> <p style="margin-left: 100px;">Last fault (H30) Current fault (HA0)</p> <p style="text-align: center;">↓</p> <p style="text-align: center;">Last fault THT Current fault OPT</p> <p>For the data codes or details of fault records, refer to the Instruction Manual (Detailed) of the inverter.</p>	Second fault in past	Latest fault	Fourth fault in past	Third fault in past	Sixth fault in past	Fifth fault in past	Eighth fault in past	Seventh fault in past	0	0	1	1	0	0	0	0	1	0	1	0	0	0	0	0
				Second fault in past	Latest fault																							
				Fourth fault in past	Third fault in past																							
				Sixth fault in past	Fifth fault in past																							
Eighth fault in past	Seventh fault in past																											
0	0	1	1	0	0	0	0	1	0	1	0	0	0	0	0													
Set frequency (RAM)	Read	H6D	Read set frequency/speed (machine speed) from RAM or EEPROM. H0000 to HE678:																									
Set frequency (EEPROM)		H6E	Set frequency: 0.01 Hz increments Speed (machine speed): 1 increments *3																									
Set frequency (RAM) *6	Write	HED	Write set frequency/speed (machine speed) to RAM or EEPROM. • H0000 to HE678 (0 to 590.00 Hz): Frequency: 0.01 Hz increments • H0000 to H270E (0 to 9998): Speed (machine speed): 1 increments *3																									
Set frequency (RAM and EEPROM) *6	Write	HEE	• To change the set frequency consecutively, write data to the inverter RAM. (Instruction code: HED)																									

Item	Read/write	Code number	Description													
Parameter	Read	H00 to H63	<ul style="list-style-type: none"> Refer to the instruction code in the Instruction Manual (Detailed) of the inverter to read and write as required. Write to Pr.77 and Pr.79 is disabled. When setting Pr.100 and later, set link parameter extended setting. Set 65520 (HFFF0) as a parameter value "8888" and 65535 (HFFFF) as "9999". When changing the parameter values frequently, set "1" in Pr.342 to write them to the RAM. (Refer to the Instruction Manual (Detailed) of the inverter for the details of Pr.342.) 													
	Write	H80 to HE3														
Faults history batch clear	Write	HF4	H9696: Clears the faults history as a batch.													
Parameter clear All parameter clear	Write	HFC	<p>All parameters return to the initial values. Whether to clear communication parameters or not can be selected according to data. (O: Clear, x: Not clear) Refer to the Instruction Manual (Detailed) of the inverter for parameter clear, all clear, and communication parameters.</p> <table border="1"> <thead> <tr> <th>Clear type</th> <th>Data</th> <th>Communication Pr.</th> </tr> </thead> <tbody> <tr> <td rowspan="2">Parameter clear</td> <td>H9696</td> <td>O</td> </tr> <tr> <td>H5A5A</td> <td>x *7</td> </tr> <tr> <td rowspan="2">All parameter clear</td> <td>H9966</td> <td>O</td> </tr> <tr> <td>H55AA</td> <td>x *7</td> </tr> </tbody> </table> <p>When clear is executed for H9696 or H9966, communication-related parameter settings also return to the initial values. When resuming operation, set the parameters again. Executing clear will clear the instruction code HEC, HF3, and HFF settings.</p>	Clear type	Data	Communication Pr.	Parameter clear	H9696	O	H5A5A	x *7	All parameter clear	H9966	O	H55AA	x *7
			Clear type	Data	Communication Pr.											
Parameter clear	H9696	O														
	H5A5A	x *7														
All parameter clear	H9966	O														
	H55AA	x *7														
Inverter reset	Write	HFD	H9696: Resets the inverter.													

Item	Read/write	Code number	Description
Second parameter changing *8	Read	H6C	Read or write of bias and gain parameters (instruction codes H5E to H61 and HDE to HE1 with the link parameter extended setting = "1", H11 to H23 and H91 to HA3 with the link parameter extended setting = "9"). H00: Frequency *9 H01: Analog value set in parameters H02: Analog value input from the terminal
	Write	HEC	

- *1 When "100" is set in **Pr.52 Operation panel main monitor selection**, set frequency is monitored during a stop and output frequency is monitored during running.
- *2 When position control is selected for the FR-A800 series, the number of pulses is monitored when **Pr.430** ≠ "9999".
- *3 Displayed increments differ according to the combination of **Pr.37**, **Pr.144**, and **Pr.811**. (**Pr.811** is only available for the FR-A800 series.) For the details, refer to the Instruction Manual (Detailed) of the inverter.
- *4 Write data is in hexadecimal, and only two digits are valid. (The upper two digits are ignored.)
- *5 Differs according to capacities.
- *6 Setting from remote registers (RWw0) can be made.
- *7 Turning OFF the power supply while clearing parameters with H5A5A or H55AA sets back the communication parameter settings back to the initial values.
- *8 Reading or writing is available when the link parameter extended setting = "1 or 9".
- *9 Gain frequencies can be written using **Pr. 125** (instruction code H99) and **Pr. 126** (instruction code H9A) also.

NOTE

- When the 32-bit parameter setting or monitor description are read and the read value exceeds HFFFF, the reply data will be HFFFF.

7.2.4 Monitor codes

Information about the inverter can be monitored by setting the special monitor selection No. of the instruction code and monitor code using the remote registers, RWw26 to 2F.



- The monitor codes (monitored items) are the same as those of the RS-485 communication dedicated monitor. For the details of the monitor code and monitor description, refer to the section of the monitor display in the Instruction Manual (Detailed) of the inverter.
- When the remote registers RWw26 to 2F are used for monitoring, H01 (output frequency) and H05 (set frequency) always indicate the frequency regardless of the settings of **Pr.37**, **Pr.144**, and **Pr.811**. (**Pr.811** is only available for the FR-A800 series.)

7.3 Torque command / torque limit through CC-Link IE Field Network communication (only for the FR-A800 series)

Torque commands can be given or the torque can be limited via CC-Link IE Field Network under Real sensorless vector control, vector control, or PM sensorless vector control. The value is used to limit the torque during speed control or position control, and to give a torque command during torque control. To limit the torque, set **Pr.810** = "2". The torque command / torque limit setting method can be selected using **Pr.804 Torque command source selection**. (Torque control cannot be performed with a PM motor.)

Pr.	Name	Initial value	Setting range	Description
804	Torque command source selection	0	0	Torque command by terminal1 analog input
			1	Torque command / torque limit through CC-Link IE Field Network communication (FR-A8NCE)
			3	<ul style="list-style-type: none"> Torque command / torque limit (-400% to 400%) by the parameter setting (Pr.805 or Pr.806) *1, *2 Torque command / torque limit (-400% to 400%) by the remote register RWw2 *2
			4	Torque command by 16-bit digital input (FR-A8AX)
			5	Torque command / torque limit through CC-Link IE Field Network communication (FR-A8NCE)
			6	<ul style="list-style-type: none"> Torque command / torque limit (-327.68% to 327.67%) by the parameter setting (Pr. 805 or Pr. 806) *1, *2 Torque command / torque limit (-327.68% to 327.67%) by the remote register RWw2 *2
810	Torque limit input method selection	0	0	Internal torque limit (torque limited by parameter settings)
			1	External torque limit (torque limited by terminals 1 and 4)
			2	Internal torque limit 2 (torque limited by communication options)

*1 Can also be set from operation panel or parameter unit.

*2 When a negative value is set as the torque limit, the torque is limited by the absolute value.

◆ RWw2 function according to the parameter settings and the control mode

Set the torque command value or the torque limit value in RWw2. The RWw2 function is switched according to the Pr.804 and Pr.810 settings and the control mode.

Pr.804 setting	Pr.810 setting	RWw2 function	
		Speed control / position control	Torque control
1, 3, 5, 6	2	Torque limit	Torque command
	0, 1	RWw2 disabled	Torque command
0, 4	—	RWw2 disabled	RWw2 disabled

◆ Relationship between the Pr.804 setting, the setting range, and the actual torque command / torque limit (when setting is made from CC-Link IE Field Network communication)

Pr.804 setting	Setting range	Actual torque command	Actual torque limit
1, 3	600 to 1400 (1% increments) *1	-400 to 400%	0 to 400%
5, 6	-32768 to 32767 (two's complement) *1	-327.68 to 327.67%	0 to 327.67%

*1 The torque limit setting is defined as an absolute value.

◆ Torque command / torque limit setting method

Setting method	Setting procedure
Writing in RWw2	<ol style="list-style-type: none"> 1. Set the torque command / torque limit value in RWw2. 2. Set "1" in RY23 (or RY24).
Writing in Pr.805 or Pr.806	<ol style="list-style-type: none"> 1. Set link parameter extended setting = H08 for RWw10 (12, 14, 16, 18, 1A). 2. Set instruction codes H85 or H86 3. Set the torque command / torque limit value in RWw11 (13, 15, 17, 19, 1B). 4. Set "1" in RY25.

◆ Supported inverters

The settings of Pr.810="2" (Internal torque limit 2) can be set only when the inverter supports the internal torque limit 2. For inverter's support of the internal torque limit 2, refer to the Instruction Manual of the inverter.

PROGRAMMING EXAMPLES

This chapter provides programming examples which control the inverter with sequence programs.

Item	Program example	Refer to page
Reading the inverter status	Reading the inverter status from the buffer memory of the master station	74
Setting the operation mode	Selecting the Network operation mode	75
Setting the operation commands	Commanding the forward rotation and middle speed signals	76
Setting the monitoring function	Monitoring the output frequency	77
Reading a parameter value	Reading the value of Pr.7 Acceleration time	78
Writing a parameter value	Setting "3.0 s" in Pr.7 Acceleration time	79
Setting the running frequency (running speed)	Setting to 50.00 Hz	80
Reading the fault records	Reading the inverter faults	82
Inverter reset	Perform inverter reset at an inverter alarm occurrence.	83

◆ System configuration for programming example

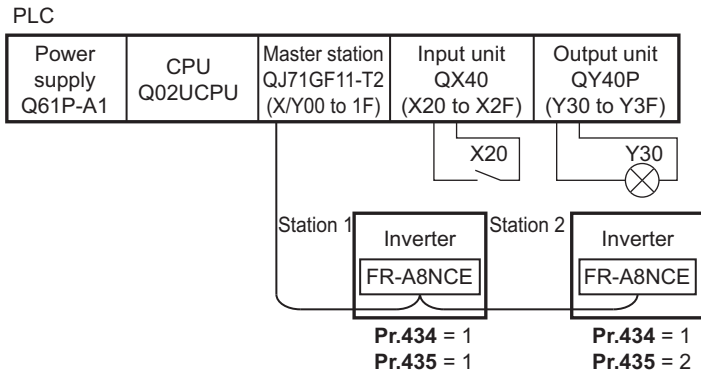

◆ Network parameter setting of the master station

In the programming example, network parameters are set as below.

- Network parameters (module 1)

Item	Setting condition
Network type	CC IE Field (master station)
Start I/O	0000
Network No.	1
Total stations	2
Mode	Online (standard mode)
Network configuration	Refer to page 71
Refresh parameter	Refer to page 71

- Network configuration (assignment method: start/end)

Item	Setting condition	
	Module 1	Module 2
Station number	1	2
Station type	Intelligent device station	Intelligent device station
RX/Ry setting	Start	0000
	End	003F
RWw/RWr setting	Start	0000
	End	007F
Reserved station/error invalid station	No setting	No setting

- Refresh parameters (assignment method: start/end)

Link side		
Device name	Start	End
SB	0000	01FF
SW	0000	01FF
RX	0000	007F
RY	0000	007F
RWr	0000	00FF
RWw	0000	00FF

↔

↔

↔

↔

↔

↔

Link side		
Device name	Start	End
SB	0000	01FF
SW	0000	01FF
X	1000	107F
Y	1000	107F
W	000000	0000FF
W	000100	0001FF

◆ Schematic diagram of remote I/O and remote register

- The remote I/O (RX, RY) transmitted between the programmable controller CPU and intelligent device stations

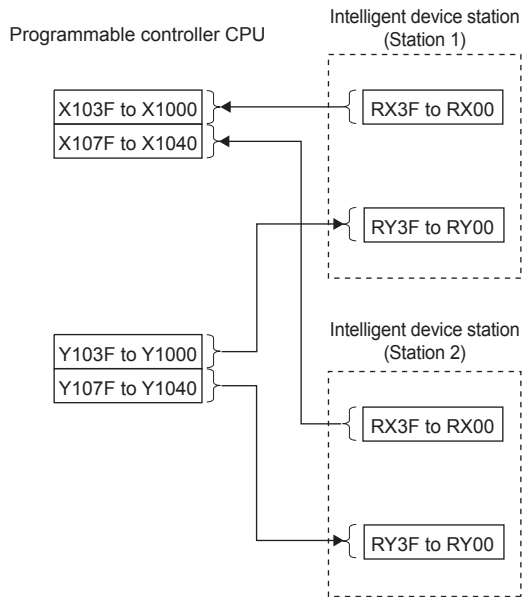

- The remote registers (RWw, RWr) transmitted between the programmable controller CPU and intelligent device stations

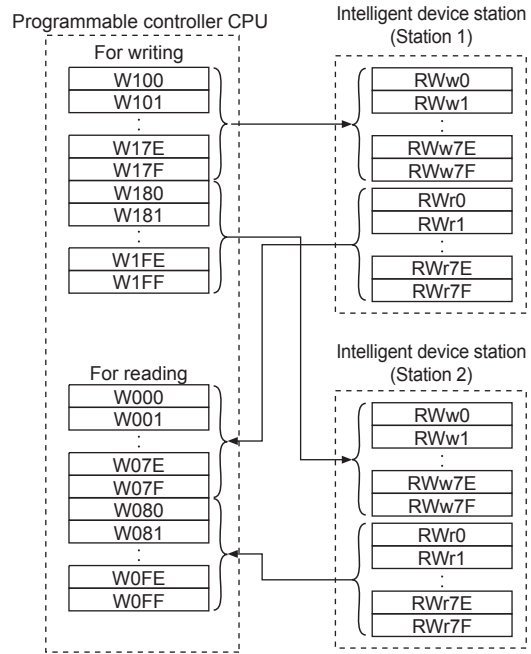

8.1 Programming example for reading the inverter status

The following program turns ON Y00 of the output unit when station 1 inverter is running.

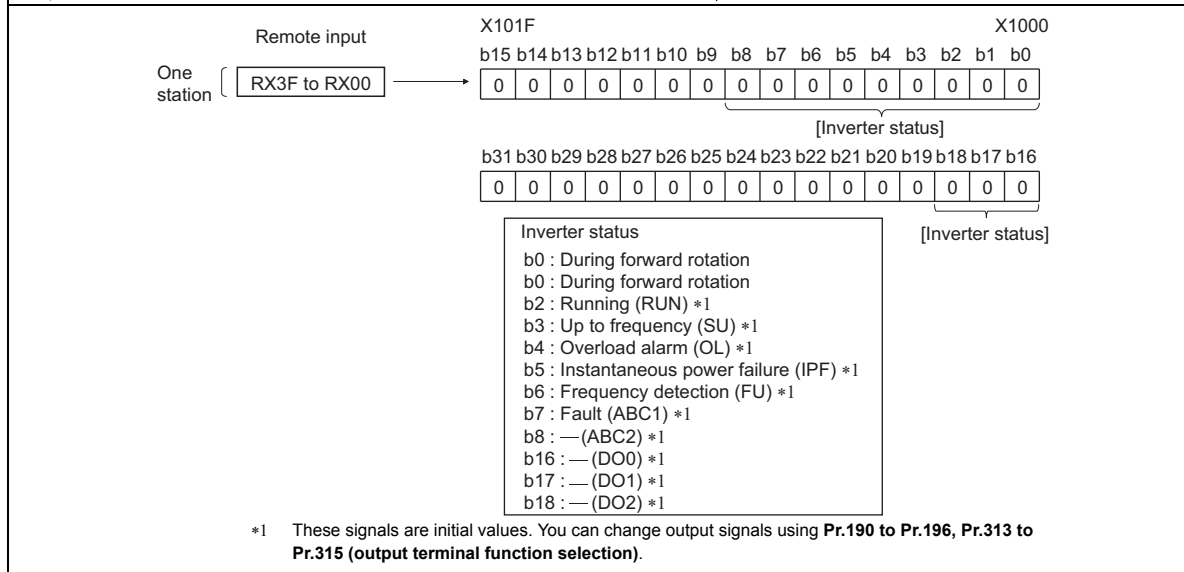
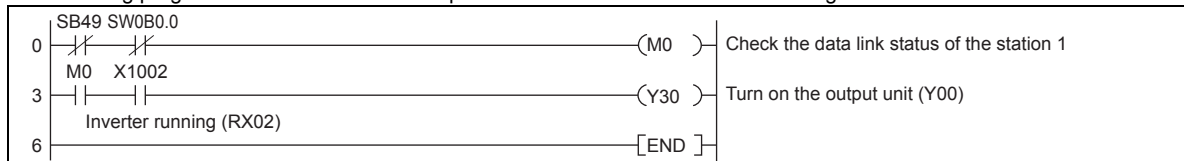

8.2 Programming example for setting the operation mode

The following explains a program to write various data to the inverter.

The following explains a program to change the operation mode of station 1 inverter to network operation.

- Operation mode write code: HFB (hexadecimal)
- Network operation set data: H0000 (hexadecimal) (Refer to [page 62](#))
- The reply code at the time of instruction code execution is set to D2. (RWr10: Refer to [page 60](#))

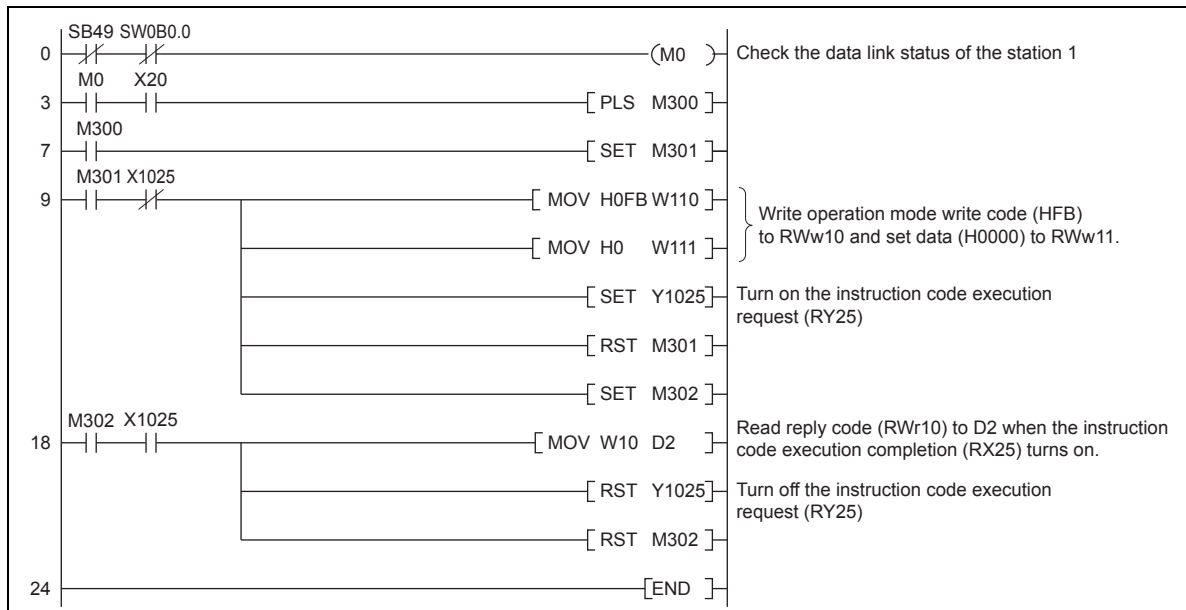

8.3 Programming example for setting the operation commands

The following program gives a forward command and middle speed command to station 1 inverter

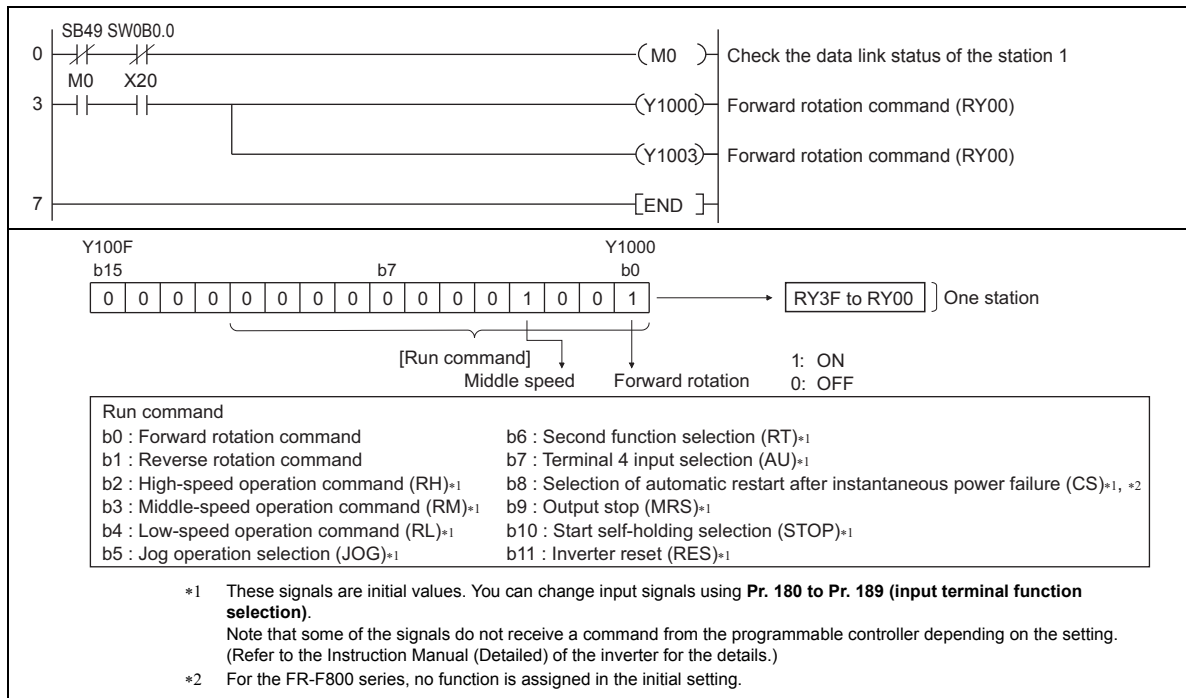

8.4 Programming example for monitoring the output frequency

The following explains a program to read monitor functions of the inverter.

The following program reads the output frequency of station 1 inverter to D1.

Output frequency read code: H0001 (hexadecimal)

For the monitor codes, refer to [page 66](#).

(Example) The output frequency of 60 Hz is indicated as H1770 (6000).

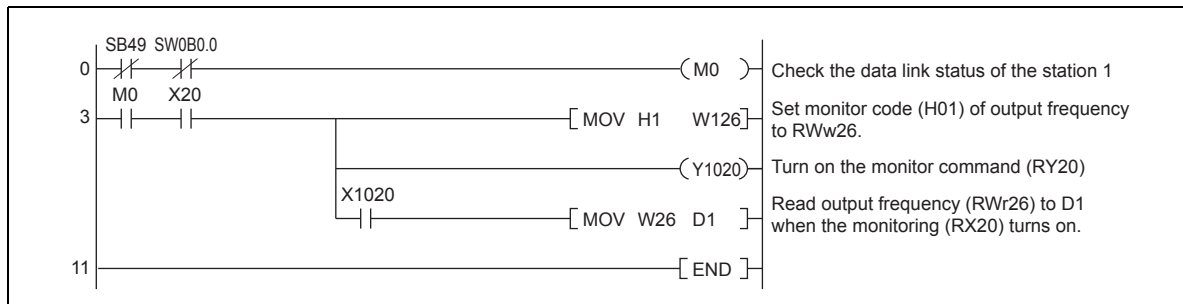

8.5 Programming example for parameter reading

The following program reads **Pr.7 Acceleration time** of station 1 inverter to D1.

- **Pr.7 Acceleration time** reading instruction code: H07 (hexadecimal)
- Refer to the Instruction Manual (Detailed) of the inverter for details of the parameter instruction code.
- The reply code at the time of instruction code execution is set to D2. (RWr10: Refer to [page 60](#))

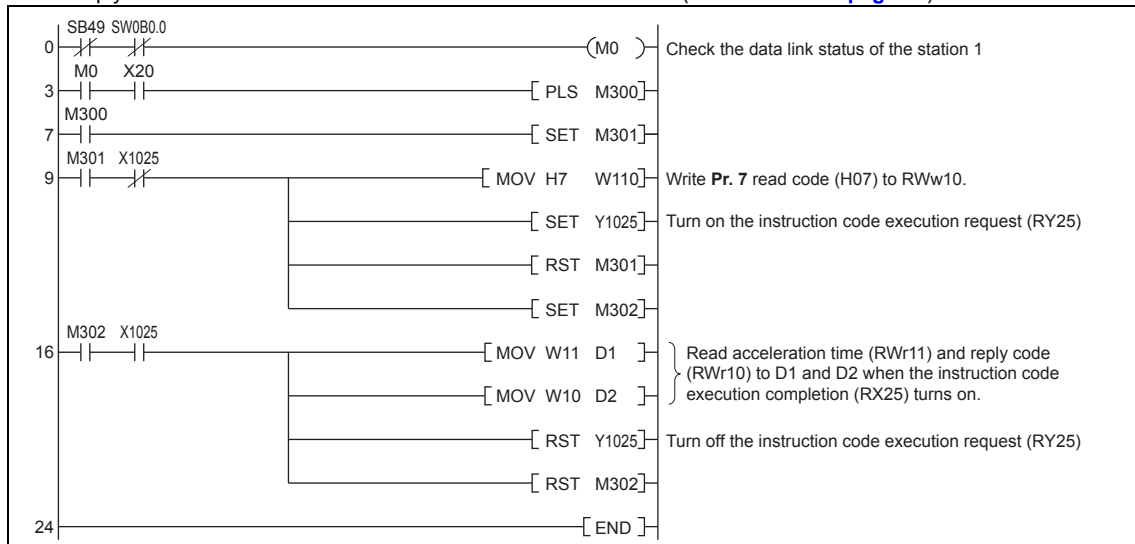

NOTE

- For parameters having numbers 100 and later, change their link parameter extended settings (set them to other than H00). Refer to the Instruction Manual (Detailed) of the inverter.

8.6 Programming example for parameter writing

The following program changes the setting of **Pr.7 Acceleration time** of inverter to 3.0 s.

- Acceleration time writing instruction code: H87 (hexadecimal)
- Acceleration time set data: K30 (decimal)

For the parameter instruction code, refer to the Instruction Manual (Detailed) of the inverter.

The reply code at the time of instruction code execution is set to D2. (RWr10: Refer to [page 60](#))

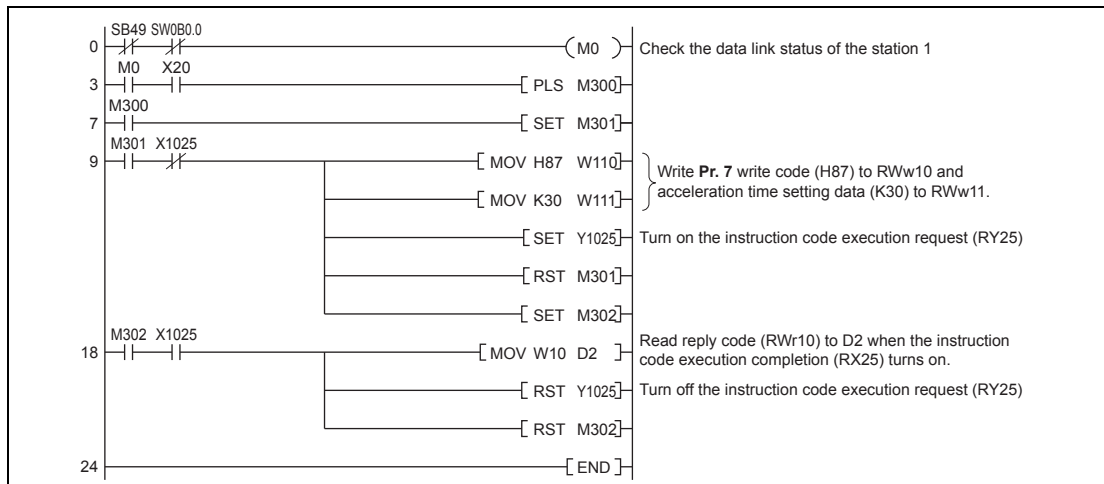

NOTE

- For parameters having numbers 100 and later, change their link parameter extended settings (set them to other than H00). Refer to the parameter list of the Instruction Manual (Detailed) of the inverter for settings.
- For other functions, refer to the instruction codes (Refer to [page 62](#)).

8.7 Programming example for setting the running frequency

◆ The following program example changes the running frequency of station 1 inverter to 50.00 Hz

Set frequency: K5000 decimal

The reply code at the time of instruction code execution is set to D2. (RWr0: Refer to [page 59](#))

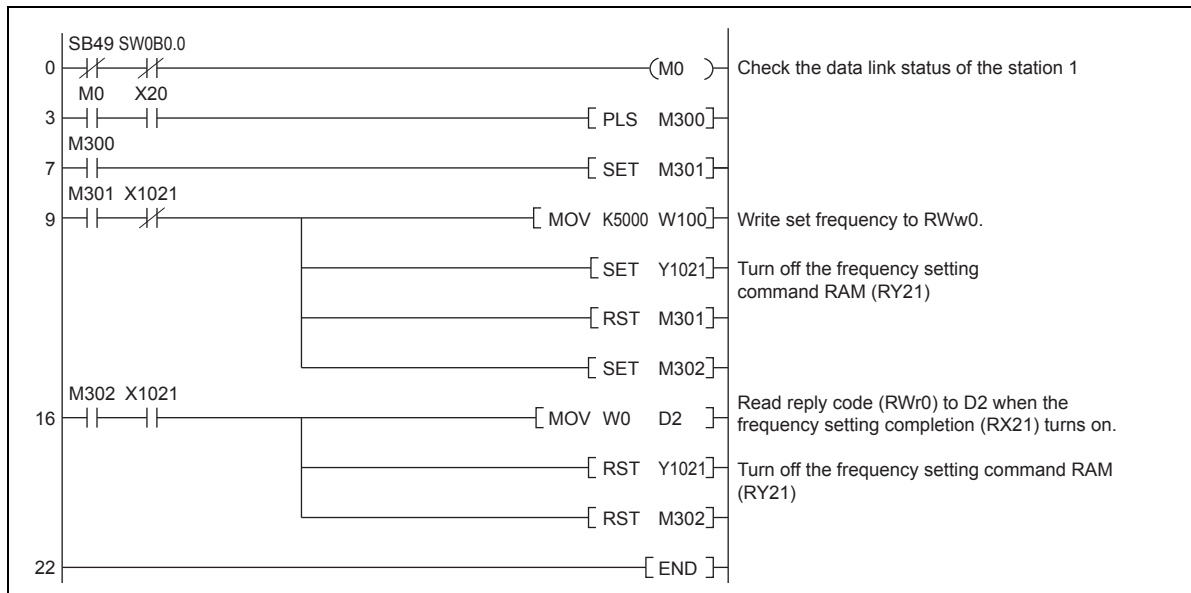

◆ To continuously change the running frequency from the programmable controller

After the frequency setting complete (for example, X1021) turns ON, check that the reply code from the intelligent register is H0000, then change the setting data (for example, W100) continuously.

◆ Program example for writing data to EEPROM

Modify the following commands of the programming example on [page 80](#).

Frequency setting command Y1021 → Y1022

Frequency setting completion X1021 → X1022

<Timing chart when writing to RAM>

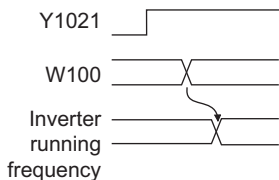

<Timing chart when writing to EEPROM>

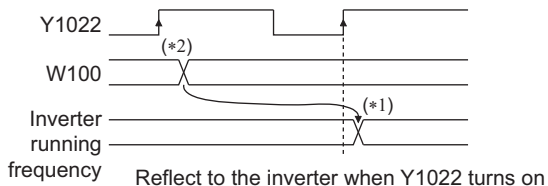

- *1 For EEPROM, write is made only once when Y1022 is switched on.
- *2 If the set data is changed with Y1022 on, it is not reflected on the inverter.

8.8 Programming example for fault record reading

The following program reads fault records of station 1 inverter to D1.

- Faults history No. 1, No. 2 reading instruction code: H74 (hexadecimal)

For the error code, refer to the Instruction Manual (Detailed) of the inverter.

The reply code at the time of instruction code execution is set to D2. (RW10: Refer to [page 60](#))

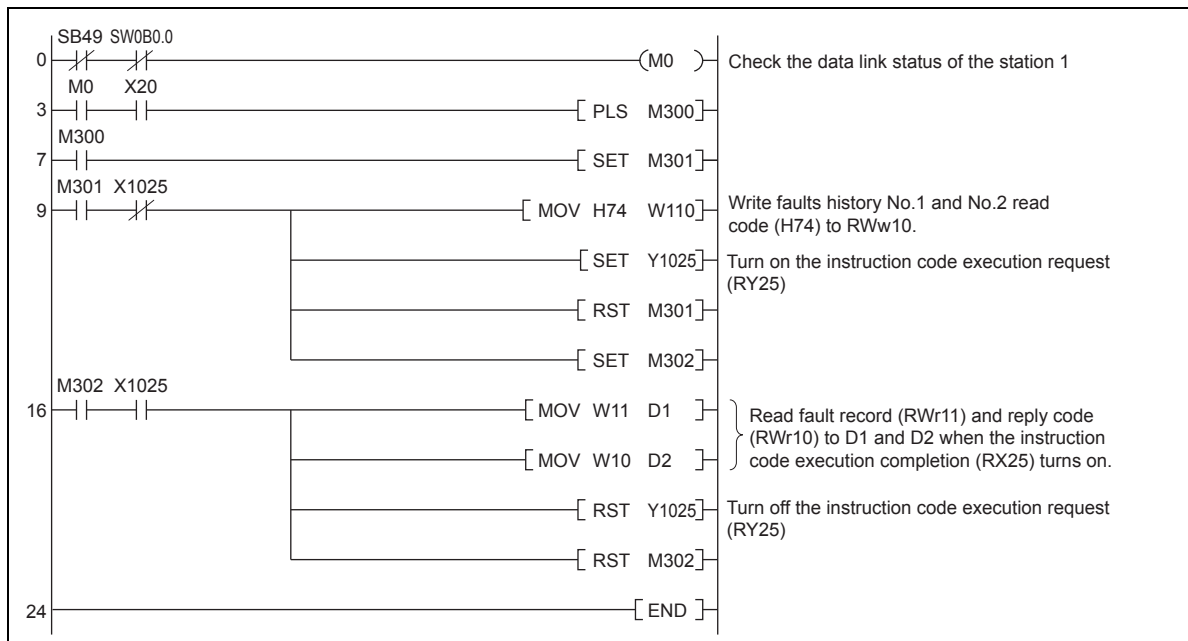

8.9 Programming example for resetting the inverter at inverter error

The following is a program example for resetting station 1 inverter at inverter error.

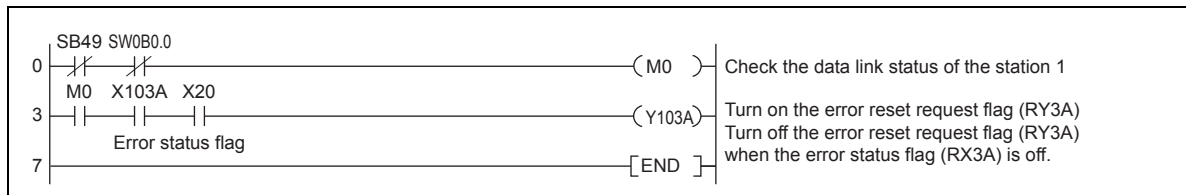

NOTE

- The above inverter reset using RY3A may be made only when an inverter error occurs.
While **Pr.349 Communication reset selection** = "0", inverter reset can be made in any operation mode.
- When using the instruction code execution request (RY25) with the instruction code (HFD) and data (H9696) to reset the inverter, set a value other than "0" in **Pr.340 Communication startup mode selection** or change the operation mode to the Network operation mode.
(For the program example, refer to [page 75](#))
- Refer to [page 28](#) for operation conditions of inverter reset.

8.10 Instructions

◆ Programming instructions

- Since the buffer memory data of the master station is kept transferred (refreshed) to/from the inverters, the TO instruction need not be executed every scan in response to data write or read requests.
The execution of the TO instruction every scan does not pose any problem.
- If the FROM/TO instruction is executed frequently, data may not be written reliably.
When transferring data between the inverter and sequence program via the buffer memory, perform the handshake to confirm that data has been written without error.

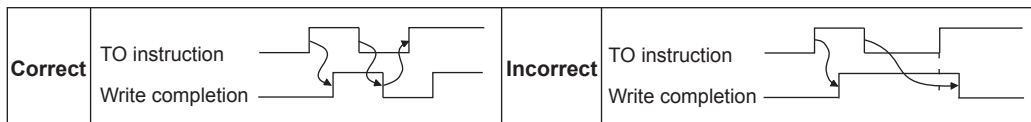

◆ Operating and handling instructions

- Command only from the programmable controller can be accepted during CC-Link IE Field Network communication.
The run command from external and parameter unit is ignored.
- If different inverters have the same station number, the communication cannot be performed properly.
- The inverter protective function (E.OP1) is activated if data communication stops for more than the time set in **Pr.500 Communication error execution waiting time** due to a programmable controller fault, an open Ethernet cable etc. during CC-Link IE Field Network operation.
- If the programmable controller (master station) is reset during CC-Link IE Field Network operation or if the programmable controller is powered OFF, data communication stops and the inverter protective function (E.OP1) is activated.
To reset the programmable controller (master station), switch the operation mode to the External operation once, then reset the programmable controller.
- When **Pr.340** = "0 (initial value)", any inverter whose main power is restored is reset to return to the External operation mode. To resume the Network operation, therefore, set the operation mode to the Network operation using the programmable controller program.
Set a value other than "0" in **Pr.340** to start in the Network operation mode after inverter reset.

◆ Troubleshooting

Description	Check point
Operation mode does not switch to the Network operation mode	Check that the option unit (FR-A8NCE) and Ethernet cables are fitted properly. (Check for contact fault, break in the cable, etc.)
	Check if Pr.434 Network number (CC-Link IE) and Pr.435 Station number (CC-Link IE) are correctly set. (Check that their settings match with the program, that the network number is set within the range, that no overlapping stations exist, and that the station number is set within the range.)
	Check that the inverter is in the External operation mode.
	Check that the operation mode switching program is running.
	Check that the operation mode switching program has been written correctly.
Inverter does not start in the Network operation mode	Check that the inverter starting program is running.
	Check that the inverter starting program has been written correctly.
	Check that Pr.338 Communication operation command source is not set to external.

REVISIONS

*The manual number is given on the bottom left of the back cover.

Print Date	*Manual Number	Revision
Sep. 2013	IB(NA)-0600509ENG-A	First edition
Feb. 2015	IB(NA)-0600509ENG-B	Addition <ul style="list-style-type: none">• Compatibility with the FR-F800 series• Compatibility with internal torque limit 2 (RWw2, Pr.810 Torque limit input method selection)

INVERTER

MITSUBISHI ELECTRIC CORPORATION

HEAD OFFICE: TOKYO BUILDING 2-7-3, MARUNOUCHI, CHIYODA-KU, TOKYO 100-8310, JAPAN